

29.2180.01.0520

FORD TRANSIT OEM FUEL FITTING INSTRUCTIONS

NOTE

The fuel tank **will** need to be lowered to access the sender unit.

Using the dimensions which are shown in (Figure 4), cut the tip of the dome off and deburr to reveal a hole in the auxiliary fuel supply port (Figure 1).

Cut 100mm from length of supplied drinking tube at the required 45 degree angle and insert the drinking tube into the auxiliary fuel port, located at the rear of the tank.

Ensure that the drinking tube is straight when fitting, or that any curvature is angled down towards the bottom of the tank.

Please refer to the photograph on the right (Figure 2) which illustrates the drinking tube.

Connect the rubber fuel hose to the plastic elbow using 9mm fuel pipe clips (Figure 3).

Attach remaining assembly to the fuel metering pump and the auxiliary fuel supply port.

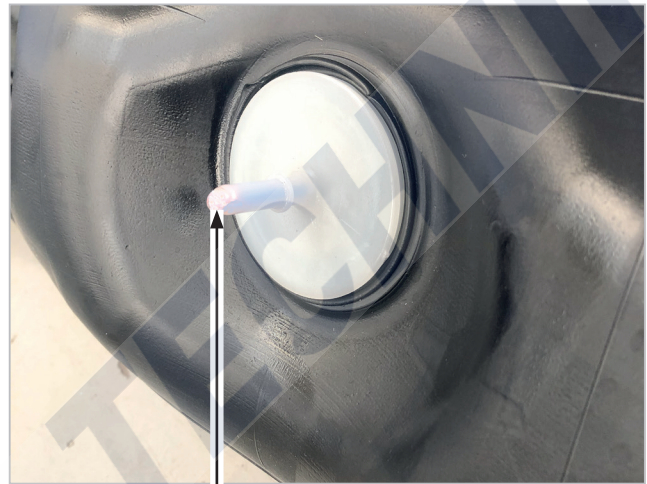

Figure 1

Auxiliary Fuel Port



Figure 2

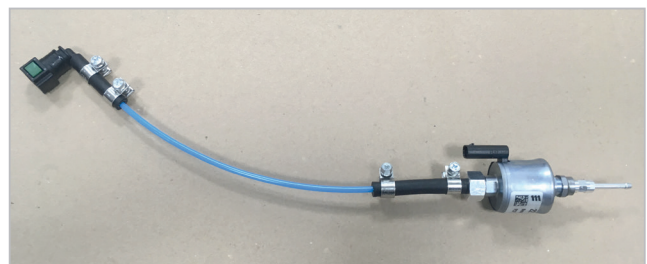

Figure 3

29.2180.01.0520

FORD TRANSIT OEM FUEL FITTING INSTRUCTIONS

! IMPORTANT!

The cut on the auxiliary fuel supply port must be made within the parameters that are set out in (Figure 4). This is to ensure an airtight seal when the heaters fuel system is connected.

The rubber seal on the drinking tube should be lubricated to avoid any damage which could in turn inhibit the supply of fuel to the heater.

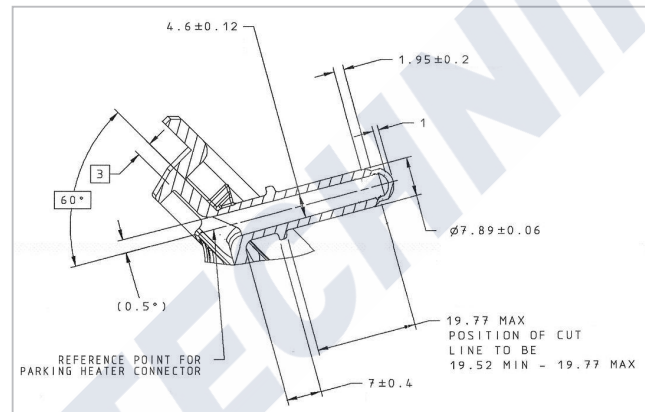

Figure 4

PART NUMBER	DESCRIPTION	QTY
29.2100.01.7943	Transit Cork Drinking Tube	1
29.2100.01.7890	Raymond Elbow Fuel Connector	1
360.75.300	Hose Fuel – 3.5 x 3mm	0.05 m
29.2100.17.1004	Clip – 9mm Pt. 46009 A	4
29.2100.17.1129	Fuel Line 2mm ID, 4mm OD Blue 2 Metre	1
360.75.300	Hose Fuel – 3.5 x 3mm	0.05 m
29.2100.20.1088	Transit OEM Fuel Fitting Instructions	1