

WORKSHOP MANUAL TECHNICAL DESCRIPTION

HYDRONIC S3 CL ECONOMY



The technical description and installation instructions are valid for the following engine-independent water heaters:

Heaters for petrol

B 4 E – 12 V CL 20 1963 05 00 00

B 5 E – 12 V CL 20 1952 05 00 00

Heaters for diesel

D 4 E – 12 V CL 25 2694 05 00 00

D 5 E – 12 V CL 25 2652 05 00 00

CONTENTS

CHAPTER	CHAPTER TITLE	PAGE
	CHAPTER CONTENTS	
1	INTRODUCTION	
	Concept of this manual	5
	Special text structure, presentation and picture symbols	6
	• Special text formats and presentations	6
	• Picture symbols	6
	Important information before starting work	6
	• Range of application of the heater	6
	• Intended purpose of the heater (via the vehicle's own heat exchanger)	6
	Statutory regulations	7
	• General regulations	7
	• Regulations concerning installation in the vehicle	7
	Hazard information and safety instructions for installation and operation	8
	Accident prevention	9
2	PRODUCT INFORMATION	
	Order No. and scope of supply	10
	• Petrol heater	10
	• Diesel heater	10
	• Heater scope of supply	10
	• Installation kit scope of supply	10
	• Parts which, if required, must be ordered separately	10
	• Connection cables / cable looms	10
	Scope of supply – heater and installation kit	11
	Technical data for the petrol heater	12
	Technical data, water pump	12
	Technical data for the diesel heater	13
	Technical data, water pump	13
	Main heater dimensions	14
	Main water pump dimensions	14
3	INSTALLATION	
	Heater installation positions	15
	• Installation position – heater upright / on its side	15
	• Installation position – heater horizontal / vertical	15
	Water pump installation position	15
	Installation location	15
	• Installation example: Petrol heater in a car	16
	• Installation example: Diesel heater in a transporter	16

CONTENTS

Fixing the heater	17
Fixing the water pump	17
Nameplate	17
Fixing the fuse holder	17
Fixing the fan relay block	18
Installing the water connection sockets	18
Connection to the coolant liquid circuit	18
• Coolant liquid circuit “inline integration”	19
• Coolant liquid circuit “inline – engine pre-heating only”	19
• Cooling liquid circuit with non-return valve and thermostat	20
• Coolant liquid circuit with combination valve	20
• Coolant liquid with 2 non-return valves	21
Exhaust system	22
• Installing the exhaust system	22
Combustion air system	23
• Installing the combustion air system	23
Fuel supply	24
• fuel extraction with tank connection or with adapter – for petrol and diesel vehicles	25
• Metering pump installation	26
• Permissible suction and pressure head of the metering pump	26
• Fuel quality for petrol heater	27
• Fuel quality for diesel heater	27
4 OPERATION AND FUNCTION	
Operating instructions	28
Important instructions for operation	28
• Initial commissioning of the heater	28
• Safety checks before starting up the heater	28
• Before switching on	28
• Parking ventilation	28
Description of functions	28
• Switching on	28
• Heating mode	28
• Pre-heater mode following lengthy stoppage	28
• Heating at high altitudes	28
Control and safety devices	29
Emergency stop – EMERGENCY OFF	29

CONTENTS

5	ELECTRICS	
	Heater wiring	30
	Parts list for circuit diagram, heater and cable harness	30
	Heater circuit diagram	31
	Cable harness circuit diagram	32
	Circuit diagram, control unit – EasyStart Timer	33
	Circuit diagram, control unit – EasyStart Remote+	34
	Circuit diagram, control unit – EasyStart Remote	35
	Circuit diagram, control unit – EasyStart Select	36
	Circuit diagram, control unit – EasyStart Web	37
6	TROUBLESHOOTING / MAINTENANCE / SERVICE	
	If faults occur, please check the following items	38
	Troubleshooting	38
	Maintenance instructions	38
	Service	38
7	ENVIRONMENT	
	Certification	39
	Disposal	39
	• Disposal of materials	39
	• Dismantling the heater	39
	• Packaging	39
	EU Declaration of Conformity	39
	Index	40
8	INDEX/LISTS	
	List of abbreviations	41

1 INTRODUCTION

CONCEPT OF THIS MANUAL

This manual aims to support the service company installing the heater and to provide the user with all important information about the heater. The manual has been divided into 8 chapters to make it easier to find the corresponding information quickly.

1 Introduction

Here you will find important introductory information about installation of the heater and about the structure of the manual.

2 Product Information

Here you will find information about the scope of supply, the technical data and the dimensions of the heater.

3 Installation

Here you will find important information and instructions referring to installation of the heater.

4 Operation and Function

Here you will find information about the operation and function of the heater.

5 Electrics

Here you will find information about the electronic system and electronic components of the heater.

6 Troubleshooting / Maintenance / Service

Here you will find information about any necessary troubleshooting procedures, maintenance and the service hotline.

7 Environment

Here you will find information about certification and disposal of the heater together with the EC Declaration of Conformity.

8 Index / Lists

Here you will find the key word list and abbreviations list.

1 INTRODUCTION

SPECIAL TEXT STRUCTURE, PRESENTATION AND PICTURE SYMBOLS

Special text formats and picture symbols are used in these instructions to emphasise different situations and subjects. Please refer to the following examples for their meanings and appropriate action.

SPECIAL TEXT FORMATS AND PRESENTATIONS

- This dot (▪) indicates a list, which is introduced by a heading.
 - If an indented dash (–) follows a “dot”, this list is a sub-section of the black dot.

Underlined blue text denotes a cross-reference, which can be clicked in the PDF format. The part of the document named in the text is then displayed.

PICTURE SYMBOLS

REGULATION!

This information indicates a statutory regulation.

Any violation of these regulations results in expiry of the type-approval for the PTC heating element and exclusion of any guarantee and liability claims against Eberspächer Climate Control Systems GmbH & Co. KG.

DANGER!

This information points out a potential serious or fatal danger. Ignoring this information can result in severe injuries.

- ➔ This arrow indicates the appropriate precaution to take to avert the danger.

ATTENTION!

This information points out a dangerous situation for a person and / or the product. Failure to comply with this information can result in personal injuries and / or damage to the unit.

- ➔ This arrow indicates the appropriate precaution to take to avert the danger.

NOTE

These remarks contain recommendations for use and useful tips for the operation, installation and repair of the heater.

IMPORTANT INFORMATION BEFORE STARTING WORK

RANGE OF APPLICATION OF THE HEATER

The water heater operating independently of an engine is intended for installation in the following vehicles:

- All kinds of vehicles
- Construction machinery
- Agricultural machinery

NOTE

The heater **cannot** be installed in vehicles used for the transport of dangerous goods according to ADR.

NOTE

The heater is not approved for mains operation (230 V / 50 Hz).

INTENDED PURPOSE OF THE HEATER (VIA THE VEHICLE'S OWN HEAT EXCHANGER)

- Pre-heating, de-misting windows
- Heating and keeping the following warm:
 - Driver and working cabs
 - Freight compartments
 - Passenger and crew compartments
 - Vehicle engines and units

On account of its functional purpose, the heater is not approved for the following applications:

- Long-term continuous operation, e.g. for preheating and heating:
 - Residential rooms
 - Garages
 - Work huts, weekend homes and hunting lodges
 - Houseboats, etc.

ATTENTION!

Use, operation and deployment of the heater outside the range indicated by the manufacturer can cause considerable injuries to people and/or damage to machinery and property.

- ➔ Only use the heater for the stipulated purpose and in the permitted range of application.

1 INTRODUCTION

STATUTORY REGULATIONS

The Federal Motor Transport Authority has issued an approval for a component according to ECE R122 and ECE-R10 for the heater for installation in motor vehicles, with the following official type-approval markings noted on the heater's nameplate.

Heater type:	ECE type approval mark:
Hydronic S3	 122 R – 000449 10 R – 047330

REGULATION!

Excerpt from ECE regulation No. 122 of the European Parliament and the Council

GENERAL REGULATIONS

- Operating state display
 - A clearly visible operating display in the user's field of vision must indicate when the heater is switched on and off.

REGULATIONS CONCERNING INSTALLATION IN THE VEHICLE

- Scope
 - Subject to differing stipulations in the following section, combustion heaters must be installed according to the regulations 5.3 of ECE-R122.
 - It is assumed that Class O vehicles with heaters for liquid fuel conform to the regulations 5.3 of ECE-R122.
- Arrangement of the heater
 - Parts of the structure and other components near the heater must be protected from excessive heat exposure and possible fuel or oil contamination.
 - The combustion heater shall not constitute a risk of fire, even in the case of overheating. This requirement shall be deemed to be met if the installation ensures an adequate distance to all parts and suitable ventilation, by the use of fire resistant materials or by the use of heat shields.
 - The heater must not be installed in the passenger compartment of class M₂ and M₃ vehicles. However, a heater in a hermetically sealed enclosure which also complies with the aforementioned conditions may be used.
 - The nameplate, or a duplicate, must be positioned so that it can be easily read when the heater is installed in the vehicle.

- Every reasonable precaution should be taken in positioning the heater to minimize the risk of injury and damage to personal property.
- Fuel supply
 - If a separate fuel tank is used, the fuel filler neck may not be located in the passenger compartment and must be fitted with a properly closing cap to prevent any fuel leaks.
 - In heaters for liquid fuel where the heater fuel supply is separate from the vehicle fuel supply, the type of fuel and filler neck must be clearly marked.
 - A warning sign is to be attached to the filler neck informing that the heater must be switched off before refuelling.
- Exhaust system
 - The exhaust outlet must be arranged so as to prevent any penetration of exhaust fumes into the vehicle interior through the ventilation system, warm air intakes or open windows.
- Combustion air intake
 - The air for the combustion chamber of the heater must not be drawn from the passenger compartment of the vehicle.
 - The air intake must be arranged or protected in such a way that it cannot be blocked by other objects.
- Automatic control of the heating system
 - If the engine fails, the heating system must be automatically switched off and the fuel supply stopped within 5 seconds. The heater may remain in operation if a manual device has already been activated.

NOTE

The heater is **not** approved for installation in the driver's cab or passenger compartment of Class M₁ vehicles (vehicles for passenger transport / cars) and N vehicles (vehicles for the transport of goods).

1 INTRODUCTION

STATUTORY REGULATIONS

NOTE

- Compliance with the statutory regulations, the additional regulations and the safety instructions is prerequisite for guarantee and liability claims.
Failure to comply with the statutory regulations and safety instructions and incorrect repairs, even if original spare parts are used, make the guarantee null and void and exclude any liability whatsoever of Eberspächer Climate Control Systems GmbH & Co. KG.
- The statutory regulations are binding and must also be observed in countries which do not have any special regulations.
- Subsequent installation of this heater must comply with these installation instructions.
- When installing the heater in vehicles not subject to the German Road Traffic Licensing Regulations (StVZO), the respective specially valid regulations and installation instructions must be observed.
- Installation of the heater in special vehicles must comply with the regulations applying to such vehicles.
- Further installation requirements are printed in the relevant sections of these installation instructions.

HAZARD INFORMATION AND SAFETY INSTRUCTIONS FOR INSTALLATION AND OPERATION

DANGER!

Risk of injury, fire and poisoning!

- ➔ Disconnect the vehicle battery before starting any kind of work.
- ➔ Before working on the heater, switch the heater off and let all hot parts cool down.
- ➔ The heater may not be operated in enclosed spaces, e.g. in the garage or in a multi-storey car park.

ATTENTION!

Safety instructions for installation and operation!

- ➔ The heater must only be installed by a Eberspächer partner authorised by the manufacturer according to the instructions in this manual and possibly according to special installation recommendations; the same applies to any repairs to be carried out in the case of repairs or guarantee claims.
- ➔ Repairs by third-parties not authorised by the manufacturer and / or with non-original spare parts are dangerous and therefore not allowed. They result in expiry of the type-approval of the heater; and thus, when installed in motor vehicles, they can cause expiry of the vehicle's operating licence.
- ➔ The following measures are not allowed:
 - Changes to heating-relevant components.
 - Use of third-party components not approved by Eberspächer Climate Control Systems GmbH & Co. KG.
 - Installation or operation deviating from the statutory regulations, safety instructions or specifications relevant to safe operation as stated in the installation instructions and operating instructions. This applies in particular to the electrical wiring, fuel supply, combustion air system and exhaust system.
- ➔ Only original accessories and original spare parts may be used for installation or repairs.
- ➔ Only control units approved by Eberspächer may be used to operate the heater.
Use of other control units can cause malfunctions.
- ➔ Before the heater is installed again in another vehicle, rinse the heater parts carrying water with clear water.
- ➔ When carrying out electric welding on the vehicle, the positive cable at the battery should be disconnected and placed at ground to protect the control box.

1 INTRODUCTION

- Defective fuses may only be replaced by fuses with the specified fuse rating.
- It is not permitted to operate the heater where there are readily flammable materials (e.g. dry grass, leaves, paper, etc.) in the area of the exhaust system or where ignitable fumes and dust can form, e.g. near a
 - fuel depot
 - coal depot
 - wood depot
 - grain depots, etc.
- The heater must be switched off when refuelling.
- If the heater is fitted in a safety casing, etc., the heater's installation box must not be used as storage space and must be kept clear. In particular, fuel canisters, oil cans, spray cans, gas cartridges, fire extinguishers, cleaning rags, items of clothing, paper etc. must not be stored or transported on or next to the heater.
- If fuel leaks from the heater fuel system, arrange for the damage to be repaired immediately by an Eberspächer partner.
- Use only anti-freeze products approved by the vehicle manufacturer to top-up; please refer to the vehicle's operating manual. Any blending with unapproved anti-freeze can cause damage to the engine and heater.
- The after-running of the heater must not be prematurely interrupted, e.g. by pressing the battery disconnecter, except for an emergency stop.

NOTE

All deviations from the safety requirements for installation and operation are to be agreed with the manufacturer.

Following installation, attach the "Switch off heater before refuelling!" sticker near the tank filler neck.

ACCIDENT PREVENTION

General accident prevention regulations and the corresponding workshop and operating safety instructions are to be observed.

2 PRODUCT INFORMATION

ORDER NO. AND SCOPE OF SUPPLY

PETROL HEATER

Fig. No.	Designation	Order No.
1	B 4 E – 12 V CL	20 1963 05 00 00
1	B 5 E – 12 V CL	20 1952 05 00 00

DIESEL HEATER

Fig. No.	Designation	Order No.
1	D 4 E – 12 V CL	25 2694 05 00 00
1	D 5 E – 12 V CL	25 2652 05 00 00

To be ordered separately:

Quantity	Designation	Order No.
1	Installation kit	25 2652 80 00 00
1	Control unit *	---

* For control unit see price list or “Product Information” document.

HEATER SCOPE OF SUPPLY

see Fig. [on page 11](#)

Fig. No.	Quantity	Designation
1	1	Heater
2	1	Metering pump
3	1	Water pump
4	1	Sensor cover
5	2	Water connection
6	2	O-ring
7	1	Screw M5 × 18
---	---	Technical documentation

INSTALLATION KIT SCOPE OF SUPPLY

see Fig. [on page 11](#)

Fig. No.	Quantity	Designation
8	1	Bracket, heater
9	1	Cable harness, heater
10	1	Lead harness, water pump
11	1	Tank connection
12	2	Water connection socket, 90°
13	1	Bracket
14	1	Bracket
15	1	Bracket, water pump
16	1	Flexible exhaust pipe, 900 mm long
17	1	Water hose
18	1	Lead harness, fan
19	1	Exhaust silencer
20	1	Fuel pipe, 4x1
21	1	Combustion air intake silencer, 760 mm long

Fig. No.	Quantity	Designation
22	1	Flexible exhaust pipe end, 300 mm long
-	1 set	Cable tie
-	1 set	Fastening parts
-	1 set	Connection parts, water
-	1 set	Fastening parts, exhaust / combustion air
-	1 set	Fastening parts, electrics
-	1 set	Fastening parts, fuel
-	1 set	Fastening parts, heater

PARTS WHICH, IF REQUIRED, MUST BE ORDERED SEPARATELY

Quantity	Designation	Order No.
1	Fuel filter	25 1226 89 00 37
2	Adapters for the fuel filter	25 1888 80 01 02
1	Kit, water circuit with thermostat	24 0347 80 00 00
1	Kit, interior or engine preheating water circuit kit	24 0349 80 00 00

To be purchased from the trade:

-	Solenoid valve, 2/2 way
---	-------------------------

CONNECTION CABLES / CABLE LOOMS

see Fig. [on page 11](#)

- A Minus supply connection
- B Diagnosis query plug connection
- C Plus supply connection
- D EasyFan modules connection
- E Control units and plus supply fan relay connection
- F Minus supply fan relay
- G Activation, vehicle fan

i NOTE

- Parts without a figure number are small parts and are packed in a bag.
- The self-tapping screws included in the installation kit can be used for metal thickness of 2 – 6 mm (tightening torque 9⁺¹ Nm).
- Please refer to the “Product Information” document if any other parts are required for the installation.

2 PRODUCT INFORMATION

SCOPE OF SUPPLY – HEATER AND INSTALLATION KIT

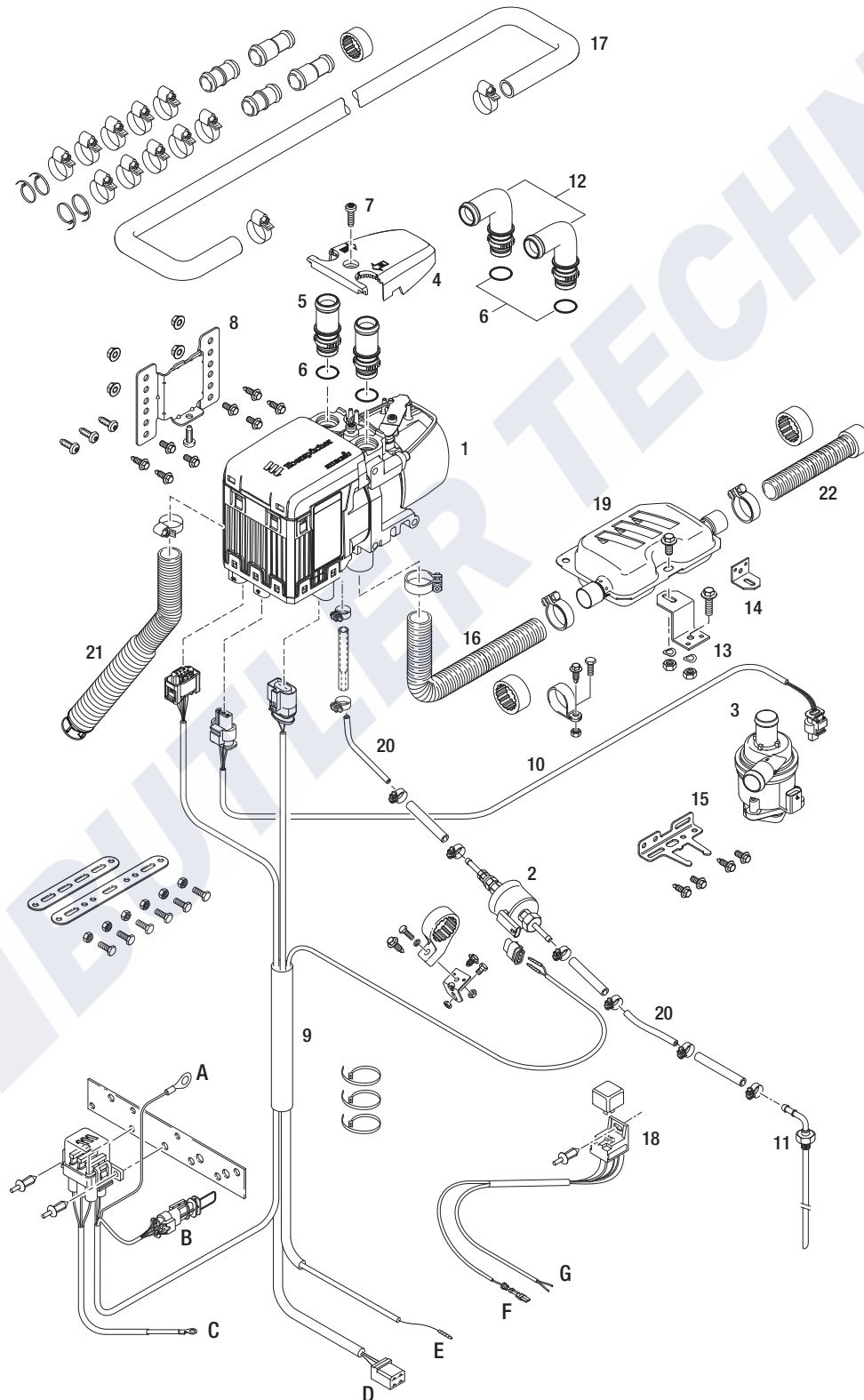

2 PRODUCT INFORMATION

TECHNICAL DATA FOR THE PETROL HEATER				
Heater type	Hydronic S3			
Heater version	B 4 E		B 5 E	
Heating medium	Mixture of water and anti-freeze (Proportion of antifreeze at least 10 % up to 50 % maximum)			
Fuel	Petrol – standard commercially available (DIN 51600 and EN 228)			
Rated voltage	12 volt			
Control of the heat flow	Maximum	Minimum	Maximum	Minimum
Heat flow (watt)	4300	1800	5000	1800
Fuel consumption (l/h)	0.57	0.23	0.67	0.23
Average electrical power consumption (watt)	during operation		24	
without water pump, without vehicle fan relay	while starting		135	
Operating range				
Lower voltage limit: An undervoltage protection installed in the control box switches off the heater if the lower voltage limit is reached.	10.5 volt			
Upper voltage limit: An overvoltage protection installed in the control box switches off the heater if the upper voltage limit is reached.	16 volt			
Allowable operating pressure	up to 2.5 bar overpressure max.			
Water volume in the heater	approx. 0.09 l			
Minimum water flow rate of the heater	300 l/h			
Allowable ambient temperature (Also note and follow the information for installation of the heater and metering pump!)	Heater	during operation	–40 °C to +60 °C	
		without operation	–40 °C to +105 °C, short-term +125 °C (5 x 2h)	
	Metering pump	during / without operation	–40 °C to +20 °C	
		Storage	–40 °C to +105 °C	
		drawn-in combustion air	max. +25 °C, short-term +45 °C (15 minutes)	
Interference suppression class	5 (EN 55025)			
Weight – without coolant liquid and additional parts	2 kg			
Protection class to DIN 40050, Part 9	Heater (in operation)		IP5K6K	
	Heater (not in operation)		IP5K9K	
TECHNICAL DATA, WATER PUMP				
Rated voltage	12 volt			
Electrical power consumption	18 watt			
Delivery rate	600 l/h			
Delivery pressure difference	0.15 bar			

 **ATTENTION!**

Operating the heater outside the specified technical data can cause malfunctions.

→ The technical data must be complied with at all times.

 **NOTE**

If no limit values are given, the technical data listed is with the usual heater tolerances of ± 10 % at nominal voltage and Esslingen reference altitude.

2 PRODUCT INFORMATION

TECHNICAL DATA FOR THE DIESEL HEATER				
Heater type	Hydronic S3			
Heater version	D 4 E		D 5 E	
Heating medium	Mixture of water and anti-freeze (Proportion of antifreeze at least 10 % up to 50 % maximum)			
Fuel	Diesel – standard commercially available (EN 590) Blending with max. 30 % FAME according to EN 14214 is permitted.			
Rated voltage	12 volt			
Working range	Maximum	Minimum	Maximum	Minimum
Heat flow (watt)	4300	1300	5000	1300
Fuel consumption (l/h)	0.53	0.15	0.59	0.15
Average electrical power consumption (watt)	during operation		while starting	
without water pump, without vehicle fan relay	27	5	32	5
Operating range	135			
Lower voltage limit: An undervoltage protection installed in the control box switches off the heater if the lower voltage limit is reached.	10.5 volt			
Upper voltage limit: An overvoltage protection installed in the control box switches off the heater if the upper voltage limit is reached.	16 volt			
Allowable operating pressure	up to 2.5 bar overpressure max.			
Water volume in the heater	approx. 0.09 l			
Minimum water flow rate of the heater	300 l/h			
Allowable ambient temperature (Also note and follow the information for installation of the heater and metering pump!)	Heater	during operation	–40 °C to +80 °C	
		without operation	–40 °C to +105 °C, short-term +125 °C (5 x 2h)	
	Metering pump	during / without operation	–40 °C to +50 °C	
		Storage	–40 °C to +105 °C	
		drawn-in combustion air	max. +45 °C, short-term +80 °C (15 minutes)	
Interference suppression class	5 (EN 55025)			
Weight – without coolant liquid and additional parts	2 kg			
Protection class to DIN 40050, Part 9	Heater (in operation)		IP5K6K	
	Heater (not in operation)		IP5K9K	
TECHNICAL DATA, WATER PUMP				
Rated voltage	12 volt			
Electrical power consumption	18 watt			
Delivery rate	600 l/h			
Delivery pressure difference	0.15 bar			



ATTENTION!

Operating the heater outside the specified technical data can cause malfunctions.

→ The technical data must be complied with at all times.



NOTE

If no limit values are given, the technical data listed is with the usual heater tolerances of ± 10 % at nominal voltage and Esslingen reference altitude.

2 PRODUCT INFORMATION

MAIN HEATER DIMENSIONS

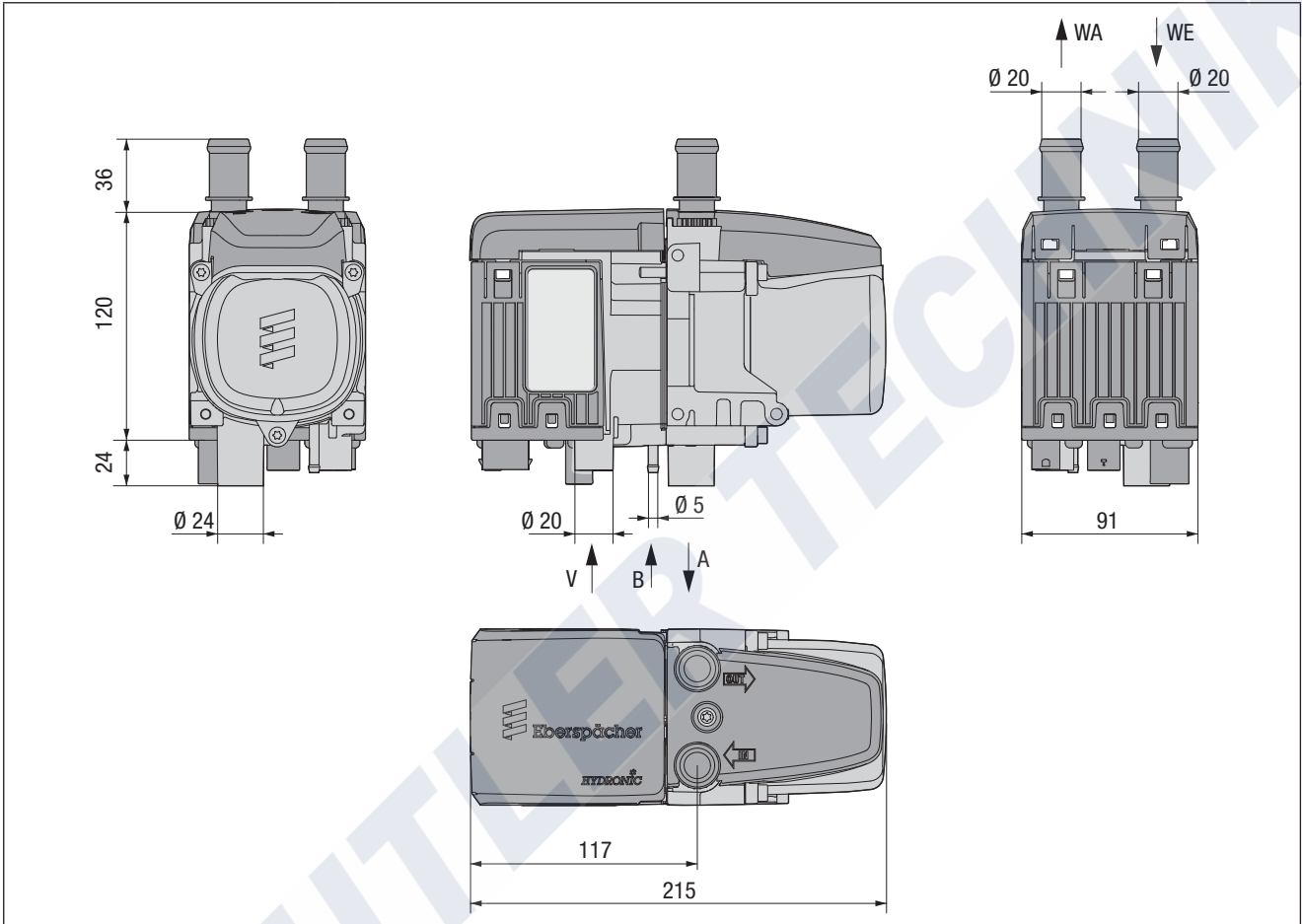

- A Exhaust
- B Fuel
- V Combustion air
- WA Water discharge
- WE Water inlet

MAIN WATER PUMP DIMENSIONS

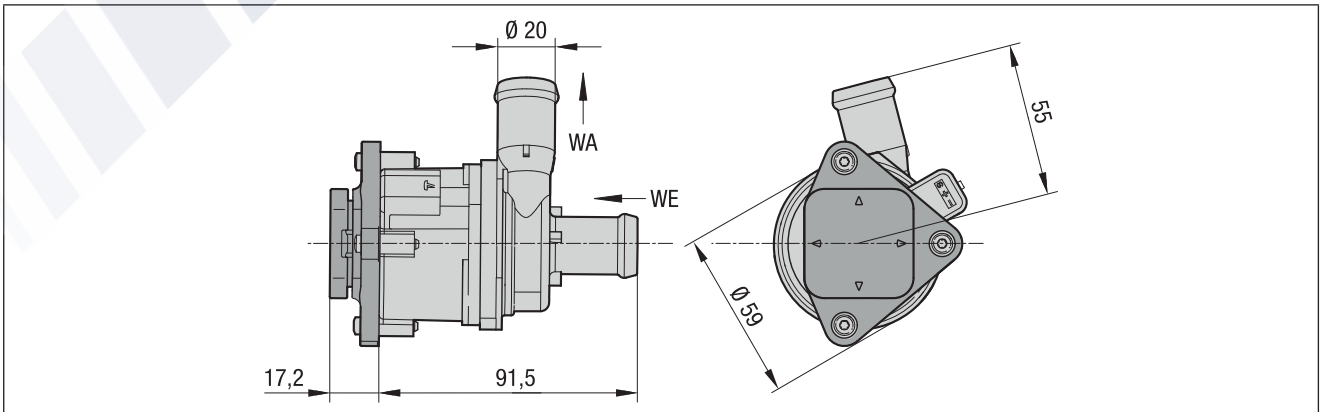

- WA Water discharge
- WE Water inlet

3 INSTALLATION

HEATER INSTALLATION POSITIONS

The heater should preferably be installed in the normal position. Depending on the installation conditions, the heater can be installed within the allowable swivel ranges.

i NOTE

In heating mode, the normal and maximum installation positions shown can differ by up to +15° in all directions for a short time. These differences, caused by tilted positions of the vehicle, do not have any negative effects on the heater's function.

INSTALLATION POSITION – HEATER UPRIGHT / ON ITS SIDE

The upright installation position (normal position) with swivel range up to the horizontal (heater on its side) installation position is allowable. All installation positions between 0° and 90° are permitted.

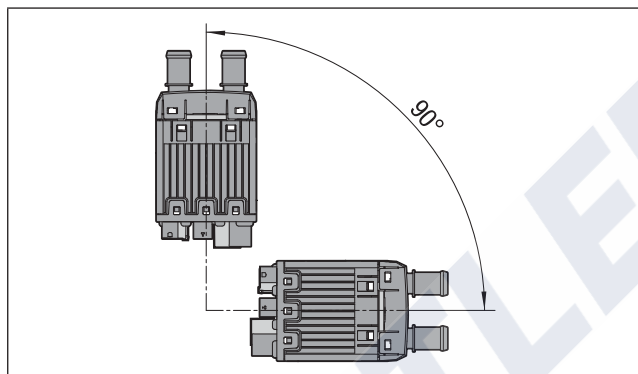

i NOTE

If a heater is swivelled out of the normal position, the exhaust connections must **always** be at the bottom.

INSTALLATION POSITION – HEATER HORIZONTAL / VERTICAL

The horizontal installation position with swivel range up to the vertical installation position is allowed. All installation positions between 0° and 90° are permitted.

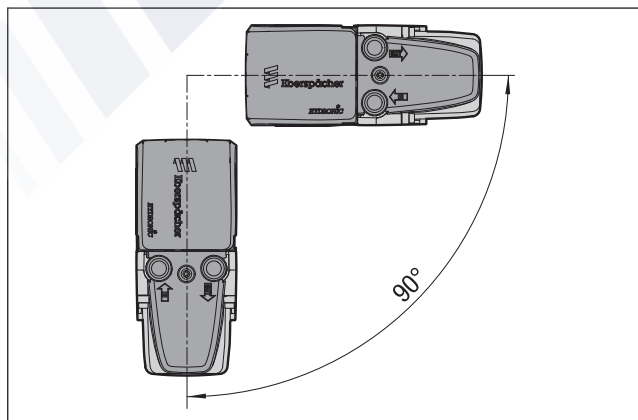

WATER PUMP INSTALLATION POSITION

Depending on the installation conditions, the water pump can be installed within the allowable swivel ranges, see sketch. The water pump is not self-priming. The water inlet must therefore be arranged so that it is always completely filled with coolant liquid.

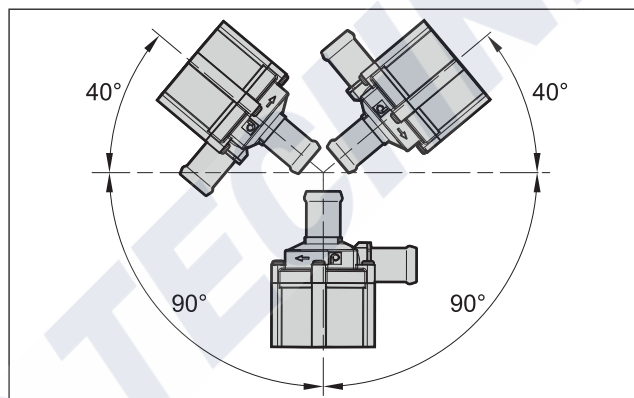

i NOTE

The installation position of the water pump with the pump head facing downwards is not permissible for automatic venting.

INSTALLATION LOCATION

The heater and the water pump are installed in the engine compartment.

The heater and the water pump must be installed below the minimum allowable coolant liquid level (header tank, radiator, vehicle's heat exchanger) so that the heat exchanger of the heater and the water pump can vent automatically.

i NOTE

- Note and observe the relevant regulations and safety instructions [from page 15](#).
- The installation suggestions made in the installation instructions are examples. Other installation locations are possible if they comply with the installation requirements stated in these installation instructions.
- Note and observe the allowable installation positions together with the operating and storage temperatures.
- Ensure adequate distance from hot vehicle parts.
- Do not install the water pump at the lowest point of the coolant liquid circuit, as otherwise the particles in the coolant liquid circuit settle in the water pump.

3 INSTALLATION

INSTALLATION EXAMPLE: PETROL HEATER IN A CAR

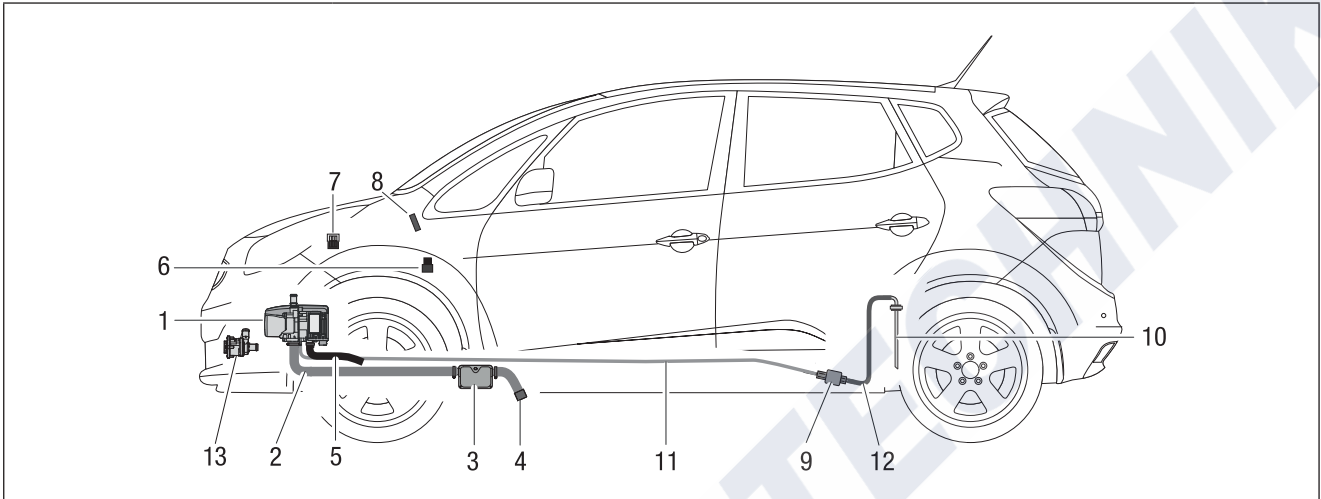

- | | | | |
|--------------------|-----------------------|--------------------|------------------|
| 1 Heater | 5 Combustion air hose | 8 Control unit | 11 Pressure line |
| 2 Exhaust pipe | 6 Fan relay | 9 Metering pump | 12 Intake line |
| 3 Exhaust silencer | 7 Fuse bracket | 10 Tank connection | 13 Water pump |
| 4 Exhaust pipe end | | | |

INSTALLATION EXAMPLE: DIESEL HEATER IN A TRANSPORTER

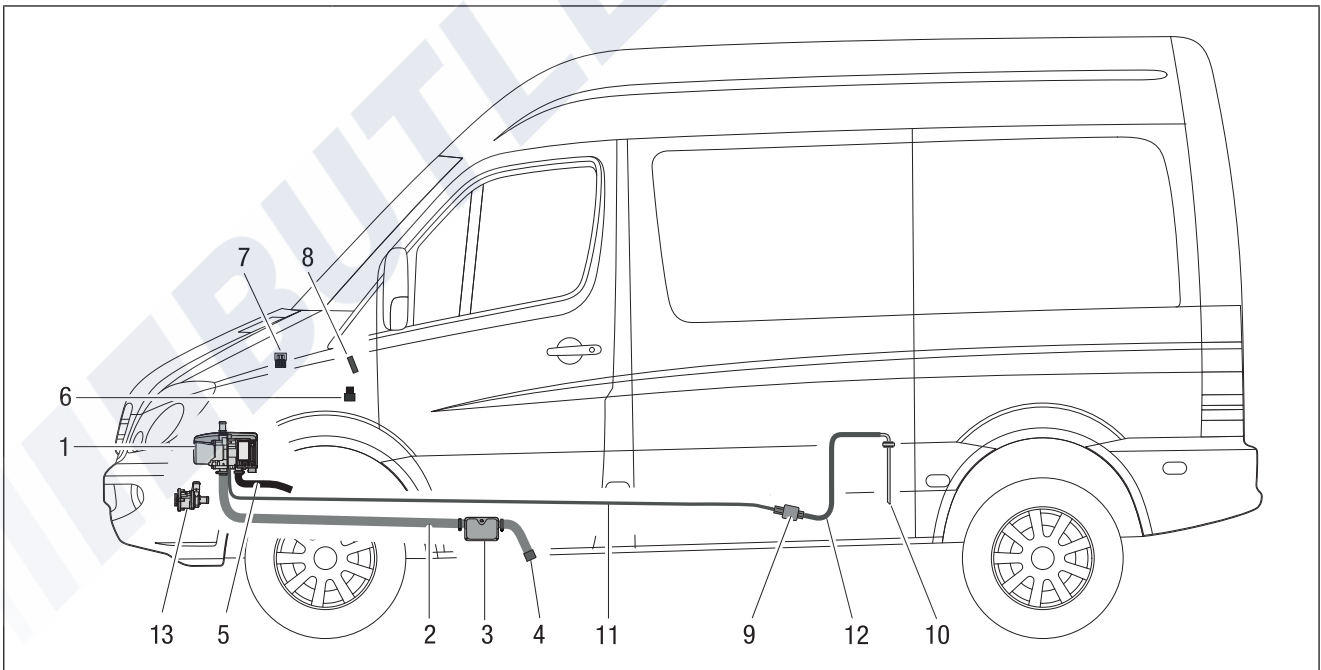

- | | | | |
|--------------------|-----------------------|--------------------|------------------|
| 1 Heater | 5 Combustion air hose | 8 Control unit | 11 Pressure line |
| 2 Exhaust pipe | 6 Fan relay | 9 Metering pump | 12 Intake line |
| 3 Exhaust silencer | 7 Fuse bracket | 10 Tank connection | 13 Water pump |
| 4 Exhaust pipe end | | | |

3 INSTALLATION

FIXING THE HEATER

Use the bracket included in the installation kit to fix the heater in a suitable position on the vehicle. The installation steps for the diesel and petrol heater are the same.

Installation steps

1. Use 4 hexagon screws M6 x 12 and 4 hexagon nuts M6 or 4 thread-forming screws to fix the bracket (tightening torque: 9^{+1} Nm).

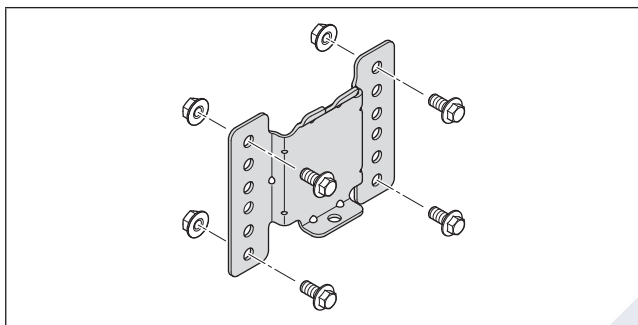

i NOTE

Preferably use the top and bottom fastening holes, see sketch. If using the other holes, ensure a minimum distance between the fastening screws.

2. Insert the heater in the bracket and fix onto the bracket with one screw M6 x 16, SW T30 (tightening torque: 10^{+1} Nm).

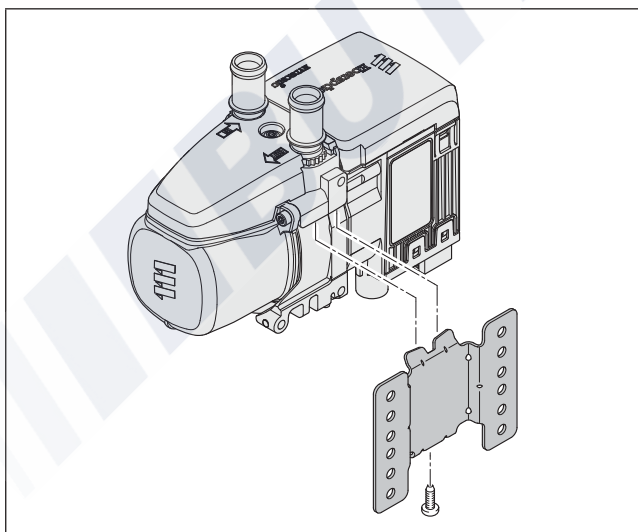

i NOTE

A thread-forming screw is used to fix the heater onto the standard bracket. It is not necessary to pre-cut a thread. The thread is formed by the screw on screwing it into the tapping hole.

Installation instructions

- Position screw by hand and screw in.
 - Always keep to the given tightening torque.
- When screwing for the second time also position by hand and do not cut a new thread.
- The screw is suitable for max. 6 installation attempts.
- In case of repair (removal of heater) a metric screw (M6 x 16) can be used as an alternative.

i NOTE

If a vehicle-specific bracket is used, the three additional thread-forming screws enclosed must be used. Tightening torque: 10^{+1} Nm.

FIXING THE WATER PUMP

Use the water pump bracket included in the installation kit to fix the water pump in a suitable position on the vehicle. Then insert the water pump in the rubber element and press in until the water pump has latched into position.

NAMEPLATE

The nameplate (1) is fastened to the side of the heater.

The 2nd nameplate (duplicate) is enclosed with the heater and must be glued onto a readily visible place in the vehicle.

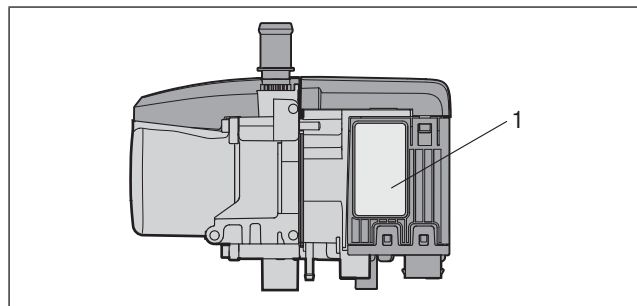

- 1 Nameplate

i NOTE

Note and observe the relevant regulations [on page 7](#).

FIXING THE FUSE HOLDER

Use a hexagon screw size M6 x 12 and hexagon nut size M6 to fix the bracket in a suitable position within the vehicle's engine compartment. Fix the fuse holder to the bracket using 2 blind rivets 4 x 8; to do this, press in the bolts of the two split rivets until the fuse holder is installed securely on the bracket.

3 INSTALLATION

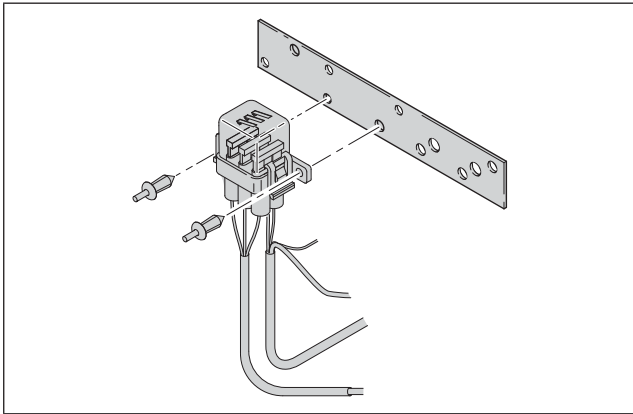

FIXING THE FAN RELAY BLOCK

Use a cable tie or blind rivet to fix the fan relay block in a suitable, accessible position inside the vehicle, to do this, push in the bolt of the split rivet 5.5 x 12 until the relay block is securely installed.

INSTALLING THE WATER CONNECTION SOCKETS

The heater scope of supply includes two straight water connection sockets and the installation kit includes two angled water sockets. Depending on the installation conditions, the straight water connection sockets (3) and the angled water connection sockets (4) can be installed with the sensor cover.

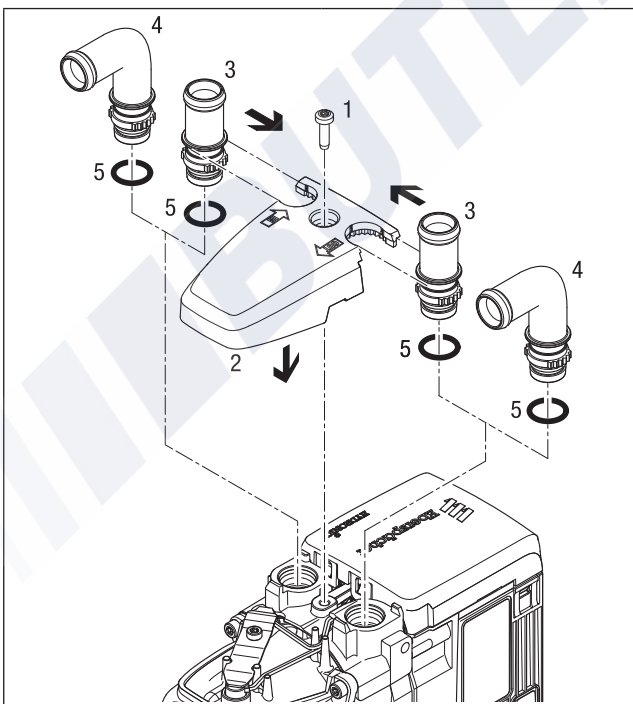

- | | |
|-------------------------------|-----------------------------|
| 1 Screw M5 x 18 | 4 Connection socket, angled |
| 2 Sensor cover | 5 O-ring |
| 3 Connection socket, straight | |

Installation steps

- Insert O-ring (5) in the groove of the connection socket.
- Insert connection sockets (3 or 4) in the recesses of the sensor cover (2). The collar at the connection socket is above the cover.
- Position and fix the connection sockets with the teething in the sensor cover.
- Position the sensor cover on the heater with the connection socket first.
- Push the connection socket completely into the connection holes in the heat exchanger.
- Adjust the direction for the angled connection sockets:
 - Lift the sensor cover up to the collar of the connection sockets
 - Turn connection socket in the required direction
 - Push sensor cover downwards and readjust the connection socket position until the teething intermesh once again
- Use screw M5 x 18 to fix the sensor cover (tightening torque $6.5^{+0.5}$ Nm).

i NOTE

A thread-forming screw is used to fix the sensor cover. It is not necessary to pre-cut a thread. The thread is formed by the screw on screwing it into the tapping hole.

Installation instructions

- Position screw by hand and screw in.
 - Always keep to the given tightening torque.
- When screwing for the second time also position by hand and do not cut a new thread.
- The screw is suitable for max. 6 installation attempts.
- In case of repair (removal of heater) a metric screw (M5 x 18) can be used as an alternative.

CONNECTION TO THE COOLANT LIQUID CIRCUIT

⚠ DANGER!

Risk of injury, scalding and burns

The high temperatures of the coolant liquid and the coolant liquid circuit components can cause injuries, scalds and burns.

- ➔ Before working on the coolant liquid circuit, wait until all components have cooled, wear safety gloves if necessary.
- ➔ Lay and fix parts carrying coolant liquid in such a way that they pose no temperature risk to man, animals or material sensitive to temperature due to radiation / direct contact.

The heater is integrated in the coolant liquid circuit in the water flow hose from the vehicle engine to the heat exchanger. There are various installation options for this. These are described [from page 19](#).

3 INSTALLATION

i NOTE

- When installing the heater, please note the direction of flow of the coolant liquid circuit.
- Fill the heater and water hose with coolant liquid before connecting to the coolant liquid circuit.
- Route the water hoses without any kinks, and in a rising position if possible.
- When laying the water hoses, maintain sufficient distance from hot vehicle parts and sharp edges.
- Protect all water hoses / water pipes from chafing and from extreme temperatures.
- Secure all hose connections with hose clips (tightening torque $3^{+0.5}$ Nm).
- Re-tighten the hose clips after the vehicle has been running for 2 hours or has travelled 100 km.
- The minimum water flow rate is ensured if, at a cooling water temperature > 60 °C, the temperature difference in the heating medium between the water inlet and water outlet does not exceed 10 K.
- Only overpressure valves with an opening pressure of min. 0.4 – max. 2 bar may be used in the coolant liquid circuit.
- The coolant liquid circuit must contain at least 10 % antifreeze all year round as corrosion protection.
- During cold periods the coolant liquid circuit must contain sufficient antifreeze. Follow the vehicle manufacturer's information regarding the mix ratio.
- Before initial commissioning of the heater or after changing the coolant liquid, the whole coolant liquid circuit including heater must be vented free of bubbles according to the instructions issued by the vehicle manufacturer.
- Only use the anti-freeze approved by the vehicle manufacturer in the allowable mix ratio (anti-freeze/ water).
- Water hoses / water pipes must be securely fixed to prevent damage and / or odour emissions due to vibrations. Recommended guide value: Fix outgoing water hoses / water pipes from the heater at a distance of approx. 20 cm with hose clips, pipe clips or cable ties.

COOLANT LIQUID CIRCUIT "INLINE INTEGRATION"

Cut the water flow hose from the vehicle engine to the vehicle's heat exchanger.

Use connectors and water hoses to connect the heater and the water pump to the water flow hose.

Lay a water hose from the discharge end of the water pump to the water inlet socket of the heater and connect.

Heating characteristics

If the heater is switched on, the heat is initially fed via the heater's own heat exchanger to the vehicle's engine only.

If the coolant liquid temperature reaches approx. 30 °C, the vehicle fan starts and the heat is also routed to the passenger compartment.

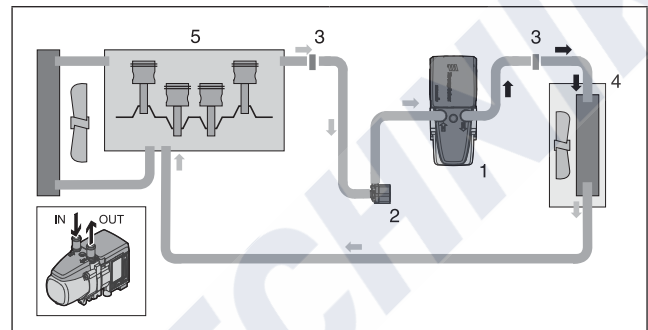

- | | |
|--------------|------------------|
| 1 Heater | 4 Heat exchanger |
| 2 Water pump | 5 Vehicle engine |
| 3 Connector | |

COOLANT LIQUID CIRCUIT "INLINE – ENGINE PRE-HEATING ONLY"

Disconnect the water return hose from the heat exchanger to the vehicle engine.

Use connectors and water hoses to connect the heater and the water pump.

Heating characteristics

For engine pre-heating only, set the temperature controller to "cold" and switch off the fan. There is thus no heat discharge into the interior of the vehicle.

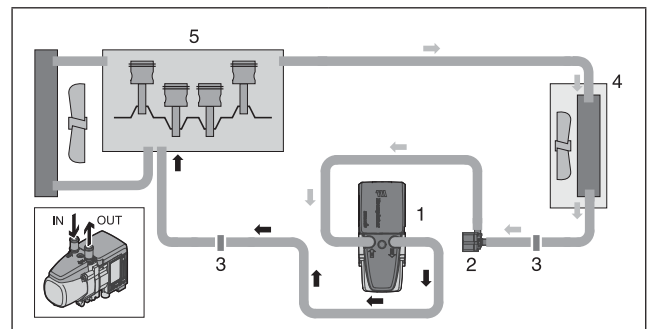

- | | |
|--------------|------------------|
| 1 Heater | 4 Heat exchanger |
| 2 Water pump | 5 Vehicle engine |
| 3 Connector | |

3 INSTALLATION

COOLING LIQUID CIRCUIT WITH NON-RETURN VALVE AND THERMOSTAT

Cut the water flow hose from the vehicle engine to the vehicle's heat exchanger and insert the non-return valve.

Cut the water return hose from the vehicle's heat exchanger to the vehicle engine and insert the T-piece.

Use water hoses to connect the heater and water pump to the thermostat, the non-return valve and T-piece – as shown in the sketch.

Heating characteristics – small cooling water circuit

Initially, up to a cooling water temperature of approx. 70 °C, the heater's heat is fed to the vehicle's heat exchanger only – fast heating of the inside of the vehicle.

Heating characteristics – large cooling water circuit

If the cooling water temperature continues to rise, the thermostat slowly switches over to the large circuit (full switchover is reached at approx. 75 °C) – heating of the inside of the vehicle and additional engine pre-heating.

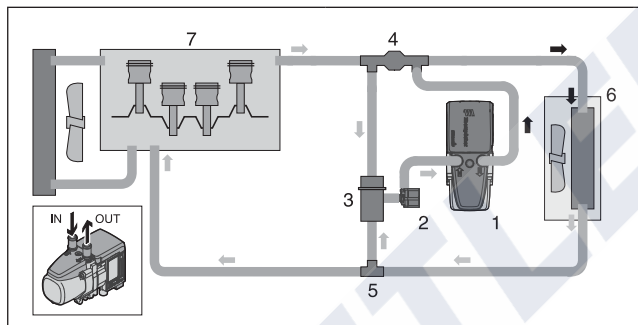

- | | |
|--------------------|------------------|
| 1 Heater | 5 T-piece |
| 2 Water pump | 6 Heat exchanger |
| 3 Thermostat | 7 Vehicle engine |
| 4 Non-return valve | |

i NOTE

The thermostat, non-return valve and T-piece must be ordered separately, please refer to the "Product information" document for the Order No.

THERMOSTAT FUNCTION

At a coolant liquid water temperature < 70 °C – small cooling water circuit:

- Socket 1 – open (to the heater)
- Socket 2 – open (to the T-piece)
- Socket 3 – closed (to the non-return valve)

At a coolant liquid temperature > 75 °C – large cooling water circuit:

- Socket 1 – open (to the heater)
- Socket 2 – closed (to the T-piece)
- Socket 3 – open (to the non-return valve)

i NOTE

Use the connections Item (1), (2) and (3) – as shown in the sketch – to integrate the thermostat in the coolant liquid circuit.

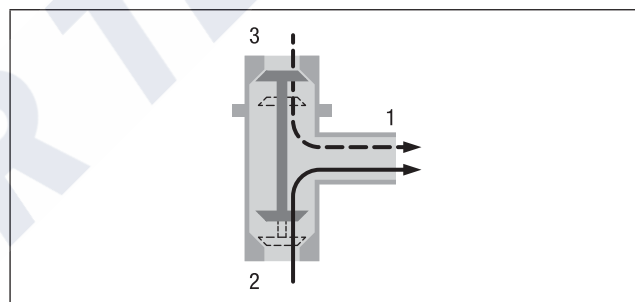

- 1 Connection socket to the heater
- 2 Connection socket to the T-piece
- 3 Connection socket to the non-return valve

COOLANT LIQUID CIRCUIT WITH COMBINATION VALVE

Using the combination valve with 5 connections

If the water flow line and water return line from the vehicle engine to the vehicle's heat exchanger are laid separately in the engine compartment, the combination valve with 5 connections and an additional T-piece must be used.

Using the combination valve with 6 connections

If the water flow line and water return line from the vehicle engine to the vehicle's heat exchanger are laid in parallel in the engine compartment, the combination valve with 6 connections (without T-piece) must be used.

Heating characteristic in pre-heater mode – small cooling water circuit

Initially, up to a cooling water temperature of approx. 67 °C, the heater's heat is fed to the vehicle's heat exchanger only – fast heating of the inside of the vehicle.

From a cooling water temperature of approx 67 °C, part of the heater's heat is also passed to the vehicle's engine. This causes additional

3 INSTALLATION

engine pre-heating, without rapid cooling of the “small cooling water circuit” for interior heating.

Heating characteristic in auxiliary heater mode – large cooling water circuit

While the vehicle's engine is running the heat is distributed between the vehicle's heat exchanger and the vehicle engine – further shortening of the heating up phase and heating of the inside of the vehicle.

Install combination valve with 5 connections

Cut the water flow hose from the vehicle engine to the vehicle's heat exchanger and insert the combination valve.

Cut the water return hose from the vehicle's heat exchanger to the vehicle engine and insert the T-piece.

Use water hoses to connect the heater and water pump to the combination valve and T-piece – as shown in the sketch.

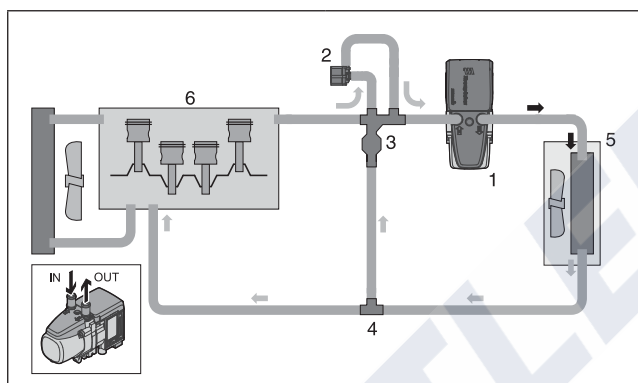

- | | |
|-------------------------------------|--------------------------|
| 1 Heater | 4 T-piece |
| 2 Water pump | 5 Vehicle heat exchanger |
| 3 combination valve (5 connections) | 6 Vehicle engine |

Install combination valve with 6 connections

Cut the water flow hose and the water return hose from the vehicle engine to the vehicle's heat exchanger and insert the combination valve.

Use water hoses to connect the heater and water pump to the combination valve – as shown in the sketch.

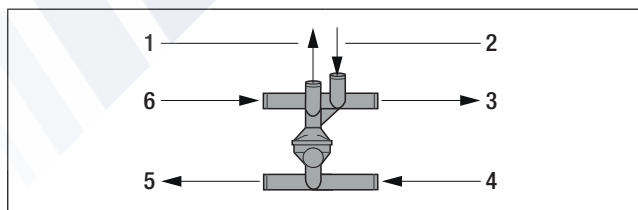

- | | |
|-----------------------|-------------------------------------|
| 1 To the water pump | 4 From the vehicle's heat exchanger |
| 2 From the water pump | 5 To the vehicle engine |
| 3 To the heater | 6 From the vehicle engine |

COOLANT LIQUID WITH 2 NON-RETURN VALVES

Preheat the vehicle interior only (vehicle engine uncoupled)

Cut the water flow hose and the water return hose from the vehicle engine to the vehicle's heat exchanger and insert one non-return valve in each.

Insert the heater between the non-return valve and the vehicle's heat exchanger in the water flow hose.

Use water hoses to connect the water pump to the non-return valves.

Heating characteristics

If the heater is switched on, the heat is only fed to the vehicle's own heat exchanger. If the coolant liquid temperature reaches approx. 30 °C, the vehicle fan starts and the heat is routed to the passenger compartment.

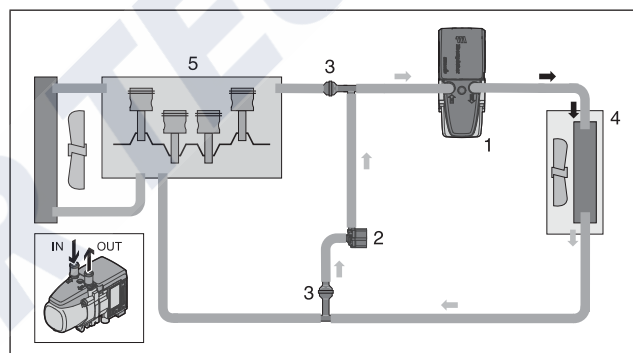

- | | |
|---------------------------------|--------------------------|
| 1 Heater | 4 Vehicle heat exchanger |
| 2 Water pump | 5 Vehicle engine |
| 3 T-piece with non-return valve | |

3 INSTALLATION

EXHAUST SYSTEM



DANGER!

Risk of injuries and burns!

Every type of combustion produces high temperatures and toxic exhaust fumes. This is why the exhaust system must always be routed as described in these installation instructions.

- Do not perform any work on the exhaust system while the heater is working.
- Before working on the exhaust system, switch off the heater first and wait until all the parts have completely cooled down, wear safety gloves if necessary.
- Do not inhale exhaust fumes.



ATTENTION!

The whole exhaust system gets very hot while the heater is running and immediately afterwards. This is why the exhaust system must always be routed as described in these installation instructions.

- The exhaust pipe must end in the open air.
- The exhaust pipe may not protrude beyond the lateral limits of the vehicle.
- Lay the exhaust pipe sloping slightly downwards. If necessary, make a drain hole with approx. \varnothing 5 mm at the lowest point as a condensation outlet.
- Important functional parts of the vehicle may not be impaired (maintain sufficient clearance).
- Mount the exhaust pipe with sufficient clearance to heat-sensitive parts. Pay particular attention to fuel lines (made of plastic or metal), electrical cables and brake hoses, etc.!
- Exhaust pipes must be safely fixed (recommended clearance of approx. 50 cm) to avoid damage from vibrations.
- Lay the exhaust system so that the outflowing exhaust gases are not drawn in as combustion air.
- The mouth of the exhaust pipe must not become clogged with dirt and snow.
- The mouth of the exhaust pipe must not point in the direction of travel.
- Always fix the exhaust silencer to the vehicle.
- Lay the exhaust system so that the exhaust fumes do not flow directly onto heat-sensitive components.

i NOTE

- Note and follow the regulations and safety instructions for this chapter [from page 8](#).
- The exhaust pipe end should be much shorter than the flexible exhaust pipe from the heater to the exhaust silencer.
- To avoid contact corrosion, the clips for fixing the exhaust pipe must be made of stainless steel. For the Order No. of the fixing clips, please refer to the "Product Information" document.

The exhaust system consists of a flexible exhaust pipe, di 24 mm, 900 mm long, a flexible exhaust pipe end with end sleeve, di 24 mm, 300 mm long and an exhaust silencer.

All parts for the exhaust system including the fixing parts are included in the installation kit (for allowable line lengths, see sketch [on page 23](#)).

INSTALLING THE EXHAUST SYSTEM

Use a bracket to fix the exhaust silencer in a suitable place on the vehicle (see sketch).

Lay the flexible exhaust pipe from the heater to the exhaust silencer and fasten with pipe clips (tightening torque $6^{+0.5}$ Nm), adjust the length if necessary.

If necessary, shorten the exhaust pipe end with end sleeve, push onto the exhaust silencer and fix with a pipe clip (tightening torque $6^{+0.5}$ Nm). If necessary, use pipe clips to fasten the flexible exhaust pipe and the exhaust pipe end in suitable positions in the vehicle (recommended guide value at approx. 50 cm spacings).

If necessary attach spacer rings on the flexible exhaust pipe and onto the exhaust pipe end, to ensure a safe distance from heat-sensitive parts of the vehicle. If applicable, use additional exhaust pipe insulation (see product information).

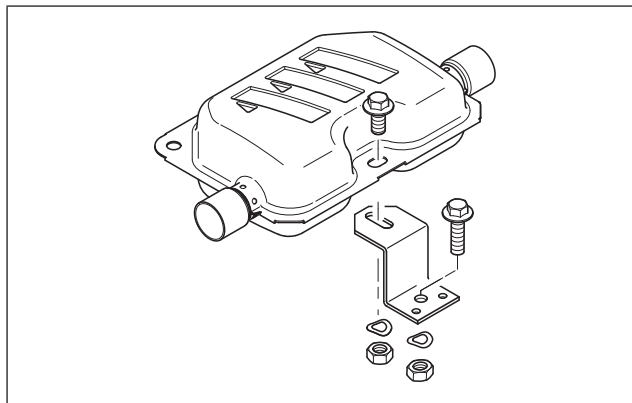

3 INSTALLATION

COMBUSTION AIR SYSTEM

ATTENTION!

Safety instructions for the combustion air system

- The combustion air opening must remain free at all times.
- Lay the combustion air intake to ensure that exhaust fumes cannot be drawn in as combustion air.
- Do not direct the combustion air intake against the vehicle's airstream.
- The combustion air intake must not become clogged with dirt and snow.
- Install the combustion air intake system sloping slightly downwards. If necessary, make a drain hole approx. \varnothing 5 mm at the lowest point to drain off condensation.
- If necessary, use fastening clips or cable ties to fix the flexible combustion air hose to the vehicle in suitable places.

INSTALLING THE COMBUSTION AIR SYSTEM

A combustion air intake silencer with flexible pipe, $d_i = 20$ mm, 760 mm long, is included in the installation kit.

Push the flexible pipe from the combustion air intake silencer onto the combustion air connection socket of the heater and fix with a hose clip (tightening torque $3^{+0.5}$ Nm).

Lay the combustion air intake silencer so that the combustion air is removed from an area, which fulfils the named conditions.

If necessary, the flexible pipe from the combustion air intake silencer can be shortened according to the installation conditions.

When shortening the flexible pipe, ensure the cutting edge is clean, small cut-off pieces could block the combustion air fan.

NOTE

Note and follow the regulations and safety instructions for this chapter [from page 7](#).

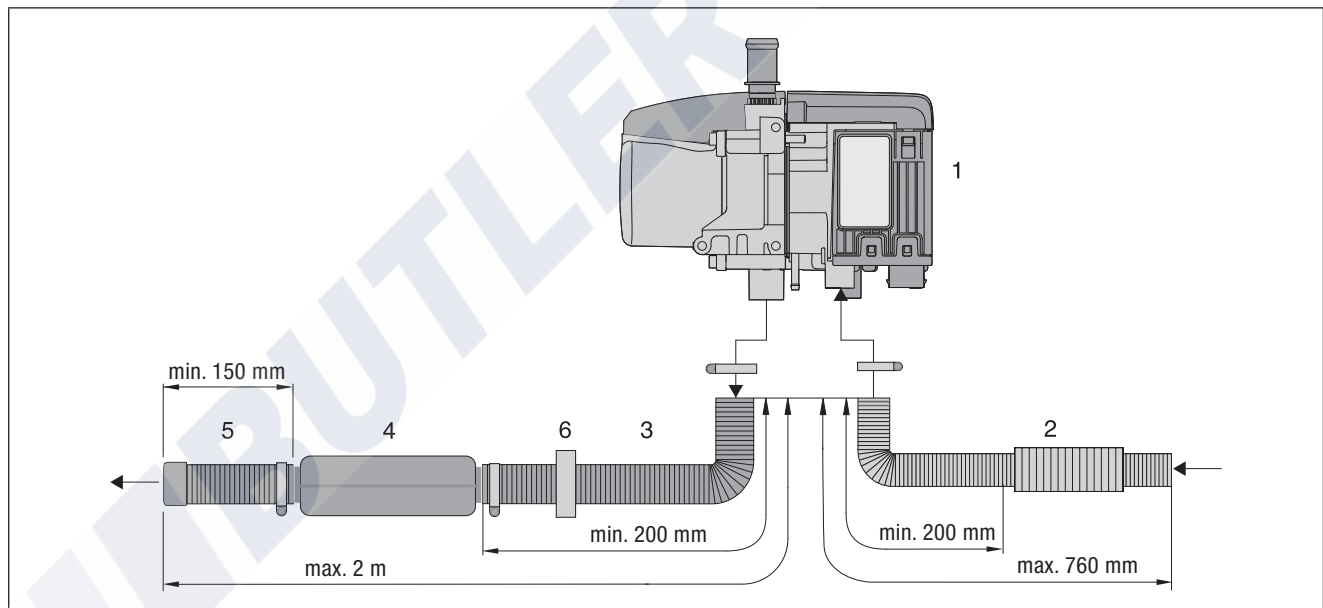

- | | |
|----------------------------------|------------------------------------|
| 1 Heater | 4 Exhaust silencer |
| 2 Combustion air intake silencer | 5 Exhaust pipe end with end sleeve |
| 3 Flexible exhaust pipe | 6 Spacer ring |

3 INSTALLATION

FUEL SUPPLY



DANGER!

Risk of fire, explosion, poisoning and injury!

Caution when handling fuel.

- Switch off the vehicle engine and the heater before refuelling and before working on the fuel supply.
- Avoid naked flames when handling fuel.
- Do not smoke.
- Do not inhale petrol fumes.
- Avoid any contact with the skin.



ATTENTION!

Always note and follow the safety instructions when installing the metering pump and when laying the fuel lines.

Deviations from the instructions stated here are not allowed.

Failure to comply can result in malfunctions.

- To install the fuel hose at the heater, moisten it and push it carefully onto the fuel connection socket.
- Use a sharp knife only to trim the fuel hoses and pipes. Interfaces must not be crushed and must be free of burrs.
- Wherever possible, lay the fuel lines from the metering pump to the heater with a continuous rise.
- Fuel lines must be securely fixed to avoid damage and / or noise due to vibrations (recommended guideline value: clearance of around 50 cm).
Especially in electric vehicles, ensure that the fuel lines are fixed so that sound transfer to the vehicle is prevented.
- Fuel lines must be protected against mechanical damage.
- Lay the fuel lines so that any twisting of the vehicle, engine movements, etc. do not have a disadvantageous effect on their durability.
- Use hose clips to secure all hose connections in the fuel supply.
- Parts carrying fuel must be protected from interfering heat.
- Never route or fasten the fuel lines directly along the heater or vehicle exhaust system.
- When systems cross, always ensure there is a sufficient heat clearance. If necessary, attach heat deflection plates.
- Dripping or evaporating fuel must never be allowed to collect on hot parts or ignite on electric equipment.

- When connecting fuel lines with a fuel hose, always install the fuel lines with a butt joint to prevent any bubbles from forming.

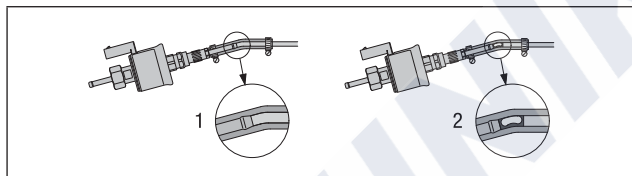

- 1 correctly laid lines
- 2 incorrectly laid lines – bubbles form



ATTENTION!

Safety instructions for fuel lines and fuel tanks in buses and coaches!

- In buses and coaches, fuel lines and fuel tanks must not be routed through the passenger compartment or driver's cab.
- Fuel tanks in buses and coaches must be positioned in such a way that the exits are not in immediate danger if a fire occurs.



NOTE

- The installation kit contains all parts required for the fuel supply.
- Note and follow the regulations and safety instructions for this chapter [from page 7](#).
- Sound insulation and abrasion protection: sponge rubber hose for fuel lines available separately as an accessory (see product information).

3 INSTALLATION

FUEL EXTRACTION WITH TANK CONNECTION OR WITH ADAPTER – FOR PETROL AND DIESEL VEHICLES

⚠ ATTENTION!

Fuel supply safety instructions!

The fuel must not be conveyed by means of gravity or overpressure in the fuel tank.

- The fuel may only be pumped by the metering pump included in the scope of supply and approved by the manufacturer.

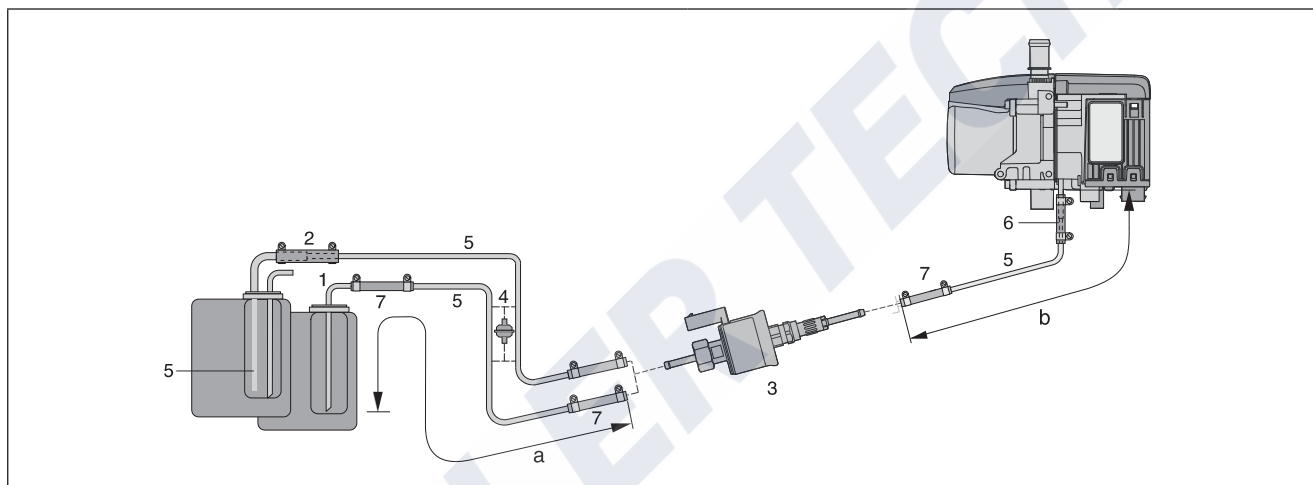

- 1 Tank connection, $d_i = \varnothing 2 \text{ mm}$, $d_a = \varnothing 4 \text{ mm}$ – installed in the vehicle's own tank fitting
- 2 Adapter, $\varnothing 7.5 / 3.5 \text{ mm}$ – connected to the vehicle's own tank fitting, at a connection socket $\varnothing 8 \text{ mm}$, used to pass through the intake line (fuel pipe 4×1) up to just before the bottom of the tank.
- 3 Metering pump
- 4 Fuel filter – only required for contaminated fuel
- 5 Fuel pipe, 4×1 ($d_i = \varnothing 2 \text{ mm}$)
- 6 Adapter, $\varnothing 4.5 / 3.5 \text{ mm}$
- 7 Fuel hose, 3.5×3 ($d_i = \varnothing 3.5 \text{ mm}$), approx. 50 mm long

Permissible line lengths

Intake side

a = max. 2 m

Pressure side

b = max. 6 m

i NOTE

- Connect fuel pipe, 4×1 , (Item 5) to the heater using adapter, $\varnothing 4.5 / 3.5 \text{ mm}$, (Item 6).
- Item 5 is not included in the "Installation kit" scope of supply. Order No. [see page 10](#).
- Installation of the fuel filter (Item 4) requires two adapters $\varnothing 5 / 3.5 \text{ mm}$, Order No. [see page 10](#).
- Use two hose clips $\varnothing 11$ to secure the adapter $\varnothing 7.5 / 3.5 \text{ mm}$ (Item 2) (tightening torque: $1^{+0.2} \text{ Nm}$).
- When installing tank connection (Item 1), maintain a minimum distance of $5^{\pm 2} \text{ mm}$ from the end of the riser to the bottom of the tank.

3 INSTALLATION

⚠ ATTENTION!

Metering pump installation safety instructions!

- ➔ Always install the metering pump with the delivery side rising upwards – minimum angle 15°.
- ➔ Do not install the metering pump and filter near silencers and exhaust pipes and therefore protect against unacceptable heating (petrol max. 20 °C, diesel max. 50 °C).

METERING PUMP INSTALLATION

Always install the metering pump with the delivery side rising upwards. Any mounting position between 15° and 90° is allowed, although a mounting position between 15° and 35° is preferable.

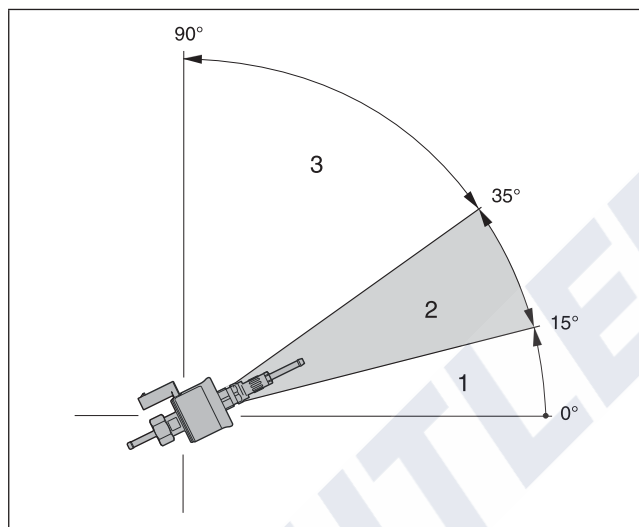

- 1 Installation position between 0° – 15° is not allowed
- 2 Preferred installation position within range 15° – 35°
- 3 Installation position within the range 35° to 90° is allowed

PERMISSIBLE SUCTION AND PRESSURE HEAD OF THE METERING PUMP

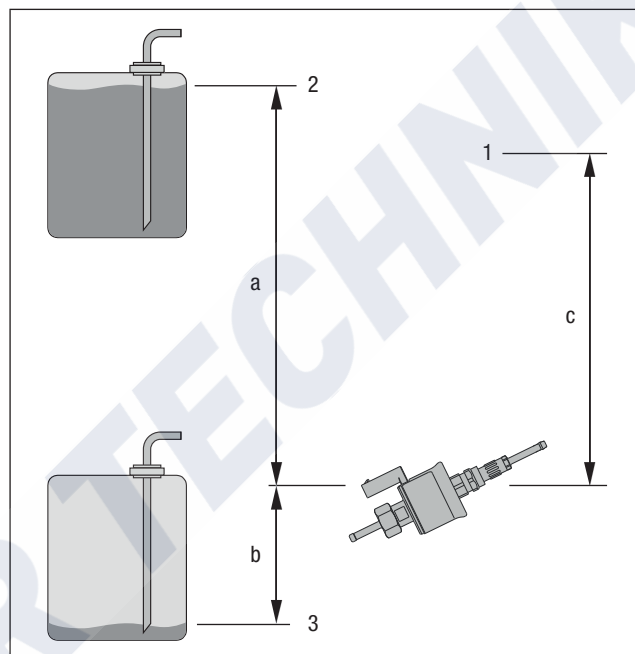

- 1 Connection at the heater
- 2 max. fuel level
- 3 min. fuel level

Pressure head from vehicle tank to metering pump:

a = max. 3000 mm

Suction head in pressure-less vehicle tank:

b = max. 500 mm for petrol

b = max. 1000 mm for diesel

Suction head in a vehicle tank in which negative pressure occurs during extraction (valve with 0.03 bar in the tank cap):

b = max. 150 mm for petrol

b = max. 400 mm for diesel

Pressure head from the metering pump to the heater:

c = max. 2000 mm

i NOTE

Check tank ventilation.

3 INSTALLATION

FUEL QUALITY FOR PETROL HEATER

The heater runs problem-free on standard commercially quality fuel, which you use to run your vehicle engine. Commercially available maximum addition of ethanol to DIN 51600 and DIN EN 228.

i NOTE

Heaters B 4 E and B 5 E are **not** approved for operation with ethanol fuel E85 to DIN 15293.

FUEL QUALITY FOR DIESEL HEATER

- The heater runs problem-free on standard commercial quality diesel fuel, which you use to run your vehicle engine. Commercially available maximum addition of biodiesel to EN 590.

During the winter months the diesel fuel is adapted to the low temperatures of 0 °C to –20 °C.

This means that problems can only arise if extreme drops in temperature occur – as is the case for the vehicle engine too – please refer to the vehicle manufacturer's instructions.

- In special cases and at outdoor temperatures above 0 °C the heater can also be run on EL heating oil according to DIN 51603 (from an additional tank).
- If the heater is run from a separate tank, please comply with the following rules:
 - at outside temperatures above 0 °C, use diesel fuel to EN 590 or EL heating oil to DIN 51603;
 - at outside temperatures of 0 °C to –20 °C, use winter diesel fuel to EN 590;
 - at outside temperatures of –20 °C to –40 °C, use Arctic diesel or polar diesel.

i NOTE

- It is **not** permitted to add used oil!
 - Following operation with winter or cold diesel, the fuel lines and the metering pump must be filled with the standard diesel fuel after letting the heater run for 15 minutes!
 - Heaters B 4 E and B 5 E are **not** approved for operation with biodiesel to DIN 14214.
-

4 OPERATION AND FUNCTION

OPERATING INSTRUCTIONS

The heater is operated by a control unit. Detailed documentation / CD for operation is enclosed with the control unit.

i NOTE

The documentation / CD will be issued to you by the installation workshop.

IMPORTANT INSTRUCTIONS FOR OPERATION

INITIAL COMMISSIONING OF THE HEATER

The following points are to be checked by the company installing the heater during initial commissioning.

- Following installation of the heater, the coolant liquid circuit and the whole fuel supply system must be carefully vented. Comply with the instructions issued by the vehicle manufacturer.
- Open the coolant circuit before the trial run (set the temperature control to "WARM").
- During the heater trial run, all water and fuel connections must be checked for leaks and secure, tight fit.
- If faults occur while the heater is running, use a diagnostic unit to determine and correct the cause of the fault.

SAFETY CHECKS BEFORE STARTING UP THE HEATER

After a lengthy stoppage (summer months), check all components for secure fit (tighten screws where necessary).

Carry out a visual check of the fuel system for leaks.

BEFORE SWITCHING ON

Before switching on or pre-programming heating mode, switch the vehicle's heating control to "WARM" (maximum setting) and the fan to "slow level" (low electricity consumption).

In vehicles with automatic heating, before switching off the ignition, switch the heating control to "MAX" and the required damper position to "OPEN".

PARKING VENTILATION

Parking / cab ventilation means: possible activation of the vehicle fan directly via the control unit or – even more useful – via the radio remote control by bypassing heating mode, in order to ventilate the often overheated vehicle interior with fresh air just before driving away.

DESCRIPTION OF FUNCTIONS

SWITCHING ON

When the heater is switched on, the  symbol appears in the control unit or the operating display lights up.

HEATING MODE

The water pump starts up and, following a preset sequence, the com-

bustion air fan, glow plug and metering pump are started.

The glow plug is switched off once a stable flame has formed in the combustion chamber.

Depending on the heat requirement, the heater adjusts continuously between the heating outputs: Max – Min – Off (pause mode). The temperature thresholds for these are permanently programmed in the electronic control box.

If the coolant liquid is cold the heater starts in "Max" control stage. If the water temperature continues rising to 75 °C (water outlet temperature of the heater), the heater adjusts the heat output continuously depending on the heat removed (heat requirement), in order to keep the water outlet temperature at a constant 75 °C. The heater provides the exact heat output required, if this is between the "MAX" and "MIN" control stages.

- If the heat output of the heater in control stage "MIN" is higher than the removed heat (heat requirement) and the water temperature rises to 85 °C, the heater adjusts to control stage "OFF" (pause mode) and then starts the after-run.
 - If the water temperature cools to 70 °C during pause mode, a controlled start follows in "MIN" control stage. The heater now adjusts the heat output continuously, depending on the removed heat, between the "MAX" and "MIN" control stages.
- During pause mode the water pump continues to run and the On symbol  continues to be displayed in the control unit.

PRE-HEATER MODE FOLLOWING LENGTHY STOPPAGE

Following a lengthy stoppage (e.g. summer break) it is recommended that you switch on the heater once while the vehicle engine is running and cold.

The empty fuel lines are filled quickly; the next start of the heater (pre-heater mode) can take place without problems.

HEATING AT HIGH ALTITUDES

When using the heater at high altitudes, please note:

- Heating at altitudes up to 1500 m:
 - Unlimited heating possible.
- Heating at altitudes over 1500 m – 3000 m:
 - The heater can be run for short periods (e.g. driving through a mountain pass or taking a break in your journey).
 - In case of a lengthy stay, e.g. winter camping, fault-free heating mode cannot be guaranteed.

4 OPERATION AND FUNCTION

CONTROL AND SAFETY DEVICES

- If the petrol heater does not ignite within 105 seconds of being switched on or the diesel heater does not ignite within 70 seconds, the start is repeated.
If the heater still does not ignite within the specified safety time (240 seconds), a safety shut-down occurs.
After an unacceptable number of failed start attempts, the control box is locked.*
 - If the flame goes off by itself during operation, the heater is restarted.
If the heater does not ignite or ignites but goes out again within 10 minutes, a safety shutdown occurs. The safety shut-down can be cancelled by briefly switching off and on again (heater ON / OFF).
 - In the case of overheating (e.g. water shortage, poorly ventilated coolant liquid circuit), the overheating sensor triggers, the fuel supply is interrupted and the heater is automatically shut down. Once the cause of the overheating has been eliminated, the heater can be re-started by switching off and on again.
Precondition: the heater has cooled down sufficiently, water temperature < 70 °C.
After a maximum of 10 shutdowns on overheating, the control box is locked*.
 - If the lower or upper voltage limit is reached, the heater is shut down automatically.
 - The heater does not start up if the glow plug is defective or if the electric cable to the metering pump is interrupted.
 - The speed of the fan motor is monitored continuously. If the fan motor does not start up, if it is blocked or if the speed falls below 40 % of the set speed, a safety shutdown occurs after 60 sec.
- * Cancellation of the lock or reading out errors is possible:
- with the EasyStart Timer.
 - with the EasyStart Remote+ radio remote control.
 - with the EasyStart Select timer.
 - with the EasyScan diagnostics tool.
 - with the EasyStart Web operating software.

For operating details and error list, refer to the »Troubleshooting and Repair Instructions« of the heater and / or the »PLUS-EasyStart / Altitude Kit Installation Instructions, Special Functions and Diagnosis«.

NOTE

Do not repeat the switching off / on routine more than twice.

EMERGENCY STOP – EMERGENCY OFF

If an emergency stop – EMERGENCY OFF – is necessary during operation, proceed as follows:

- Switch the heater off at the control unit or
- remove the fuse or
- disconnect the heater from the battery.

5 ELECTRICS

HEATER WIRING



ATTENTION!

Safety instructions for wiring the heater!

The heater is to be connected up **electriWeby** according to the EMC directives. EMC can be affected if the heater is not connected up correctly. For this reason, comply with the following instructions:

- ➔ Ensure that the insulation of electrical cables is not damaged.
 - Avoid:
 - chafing, kinking, jamming or exposure to heat.
- ➔ Seal any connector chambers of watertight connectors not in use with filler plugs to ensure they are dirt-proof and water-proof.
- ➔ Electrical connections and negative connections must be free of corrosion and firmly connected.
- ➔ Lubricate connections and ground connections outside the heater interior with contact grease.



NOTE

- Electrical leads and components must be positioned in the vehicle so that they can function perfectly under normal operating conditions without impairment (e.g. due to heat exposure, moisture, etc.).
- Ensure that you keep to the specified cable length and cable cross-section of the positive cable 4² and the negative cable 2.5² between the battery and the heater.

This ensures that the max. allowable voltage drop in the cables does not exceed 0.5 V for 12 V rated voltage.

If the cable (positive cable + negative cable) is lengthened up to 6 m, the next-higher cable cross-section must be selected.
- If the positive cable is to be connected to the fuse box (e.g. terminal 30), the vehicle's cable from the battery to the fuse box must also be included in the calculation for the total cable length and re-dimensioned if necessary.
- Insulate unused cable ends.
- The 12 volt relay (-K1, from terminal 30 to terminal 87a) has a maximum current carrying capacity of 40 A; i.e. the value of the vehicle's own fan fuse may not be more than 40 A. Circuit diagram [see page 32](#).

PARTS LIST FOR CIRCUIT DIAGRAM, HEATER AND CABLE HARNESS

-A10	Control box
-A30	Fuse holder, 3 pin
-B5	Flame sensor
-B10	WAF
-B11	WEF
-F1	Fuse, heater
-F2	Fuse, control unit
-F3	Fan relay fuse
-K1	Fan relay
-M3	Burner motor
-M10	Water pump
-R1	Glow plug
-R2	Terminating resistor 120 Ω
-R3	Terminating resistor 9,2 Ω
-X1	Ring terminal end
-XB1	Bush housing, heater power supply
-XB2	Bush housing, heater signals
-XB3	Bush housing, heater water pump
-XB6/1	Bush housing, EasyScan
-XB6/3	Bush housing, EasyFan
-XB7	Relay block
-XB8/1	Bush housing, metering pump plug-in connection
-XB8/2	Bush housing, water pump
-XS6/1	Mating connector with terminating resistor
-XS8	Connector housing, metering pump plug-in connection
-Y1	Fuel metering pump
a	to the heater
b	Activation, vehicle fan
c	to the cable harness
d	to the control unit
e	EasyScan connection
f	EasyFan connection

Cable colours

RD	red	GR	grey	BK	black
BU	blue	YE	yellow	GN	green
WH	white	VT	violet	BN	brown

5 ELECTRICS

HEATER CIRCUIT DIAGRAM

- X:15 ○ _____
- Ign (+)
- X:58 ○ _____
- Light (+)
- X:30 ○ _____
- Bat (+)
- X:31 ○ _____
- Bat (-)

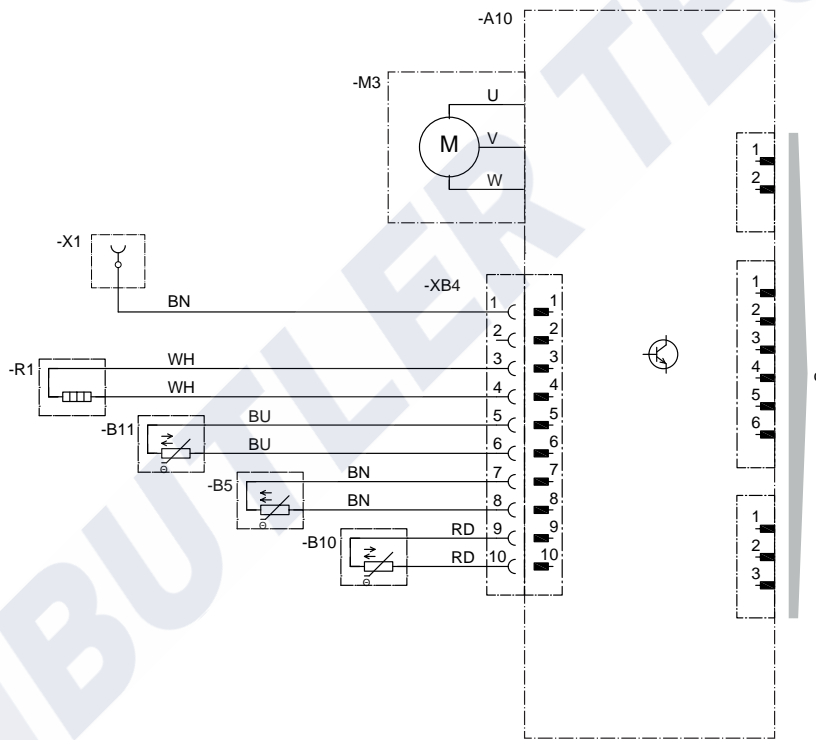

Parts list [see page 30](#)

25 2652 00 96 01 B

5 ELECTRICS

CABLE HARNESS CIRCUIT DIAGRAM

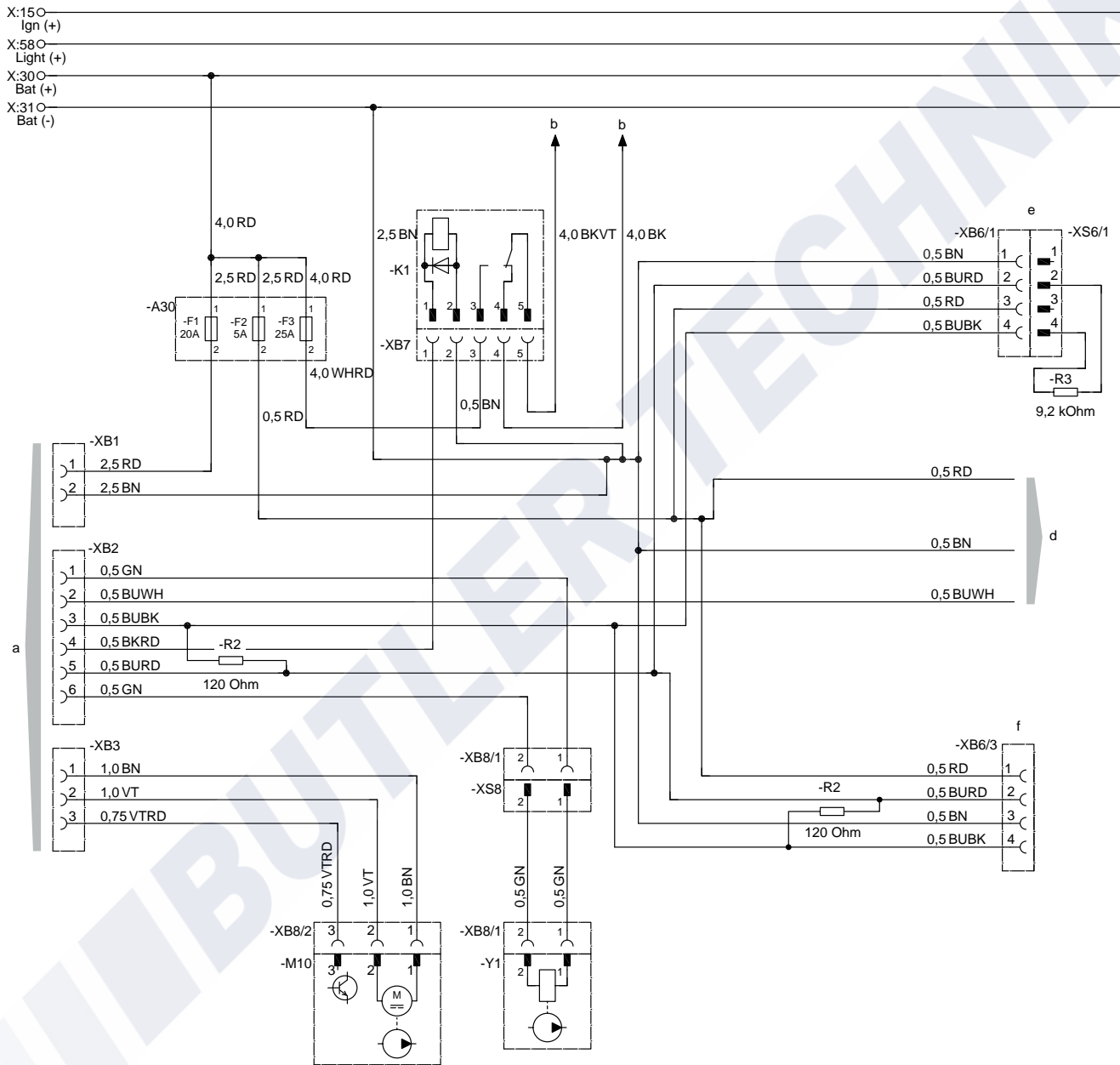

Parts list [see page 30](#)

25 2652 00 96 02 B

5 ELECTRICS

CIRCUIT DIAGRAM, CONTROL UNIT – EASYSTART TIMER

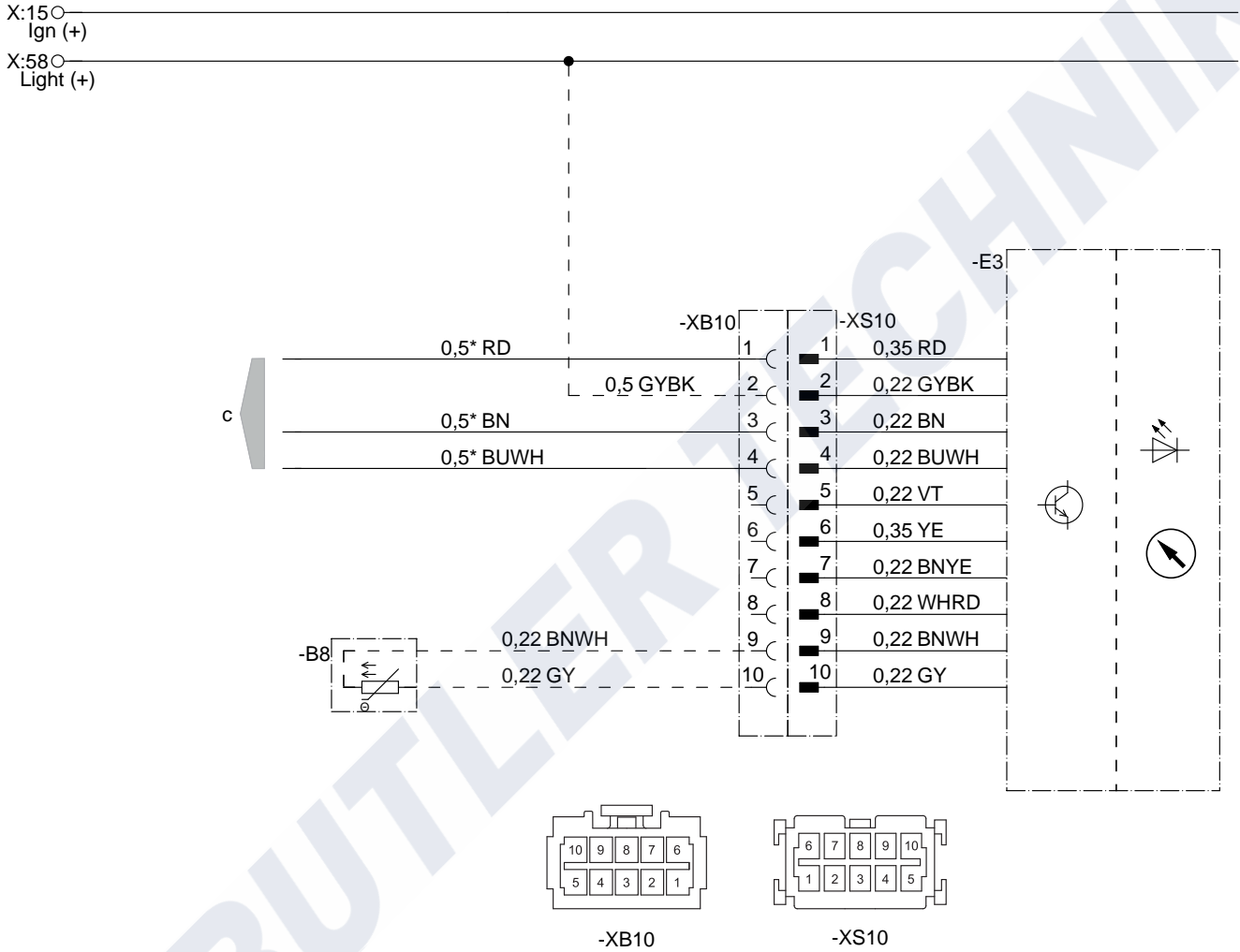

22 1000 34 97 01

Parts list

- B8 Room temperature sensor (optional)
- E3 EasyStart Timer
- c to the cable harness

Connectors and bush housings are shown from the cable inlet side.

NOTE

Further circuit diagrams for the EasyStart timer are printed in the Installation Instructions Plus, these are available to view and download from the Service Portal.

5 ELECTRICS

CIRCUIT DIAGRAM, CONTROL UNIT – EASYSTART REMOTE+

X:15 ○
Ign (+)

X:58 ○
Light (+)

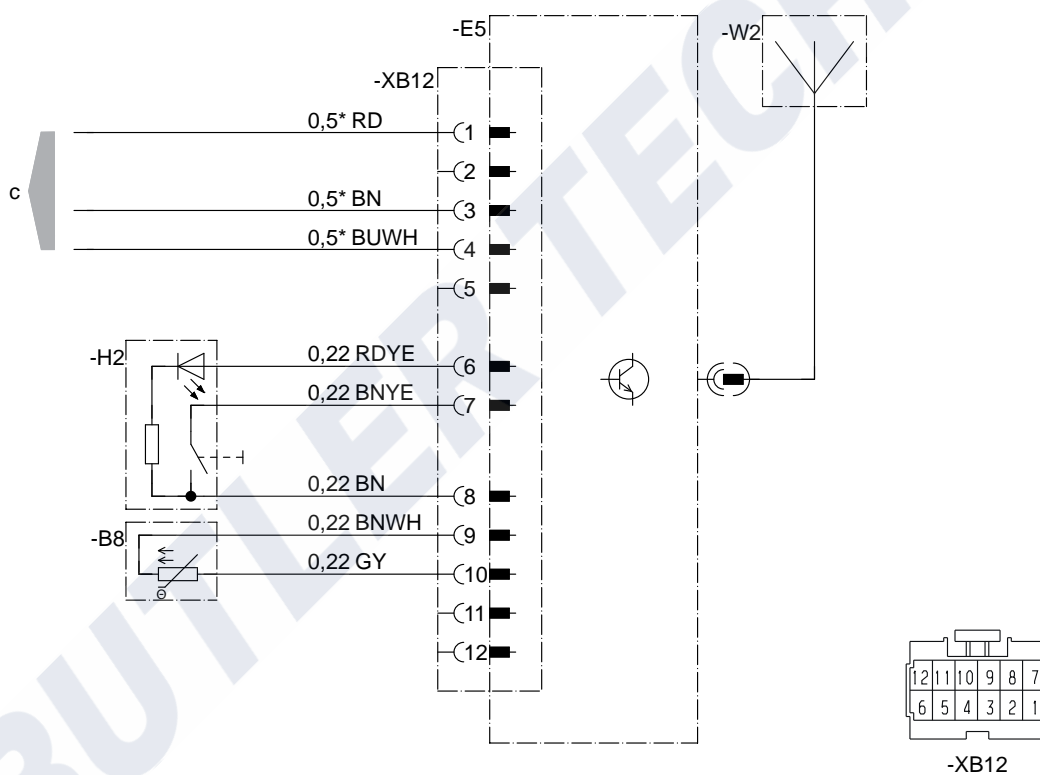

22 1000 34 97 22

Parts list

- B8 Room temperature sensor
- E5 Stationary unit, EasyStart Remote+
- H2 Button
- W2 Antenna
- c to the cable harness

Connectors and bush housings are shown from the cable inlet side.

i NOTE

Further circuit diagrams for the EasyStart Remote+ are printed in the Installation Instructions Plus, these are available to view and download from the Service Portal.

5 ELECTRICS

CIRCUIT DIAGRAM, CONTROL UNIT – EASYSTART REMOTE

X:15  Ign (+)

X:58  Light (+)

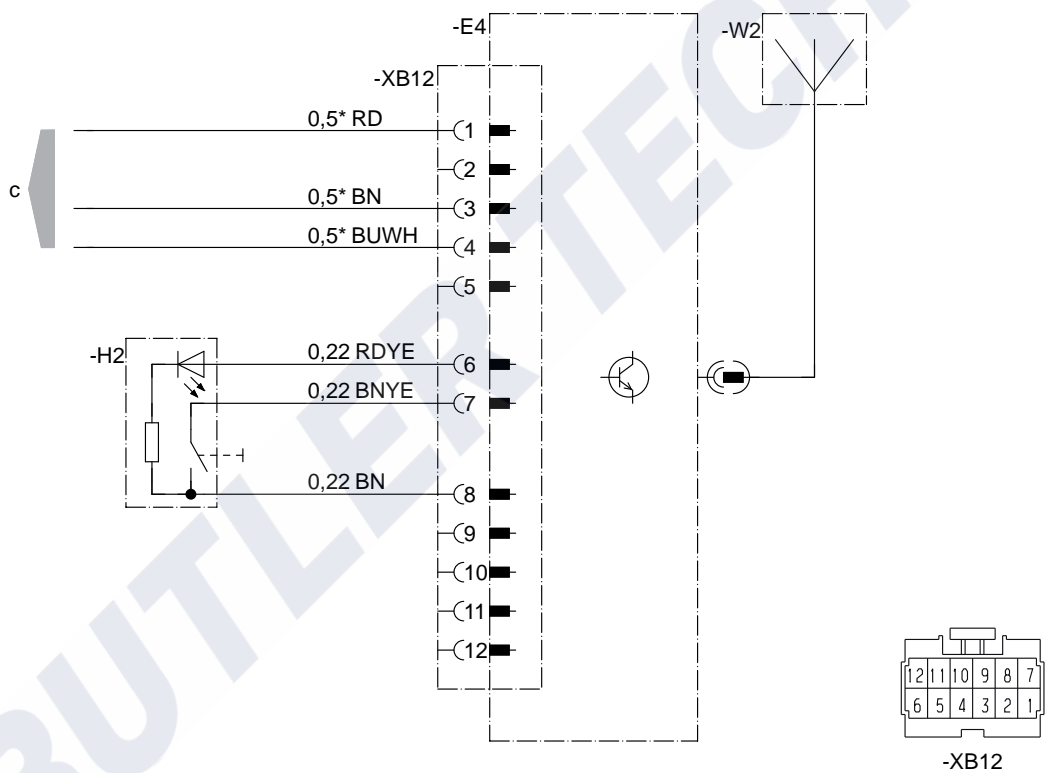

22 1000 34 97 33

Parts list

- E4 Stationary unit EasyStart Remote
- H2 Button
- W2 Antenna
- c to the cable harness

Connectors and bush housings are shown from the cable inlet side.

i NOTE

Further circuit diagrams for the EasyStart Remote are printed in the Installation Instructions Plus, these are available to view and download from the Service Portal.

5 ELECTRICS

CIRCUIT DIAGRAM, CONTROL UNIT – EASYSTART SELECT

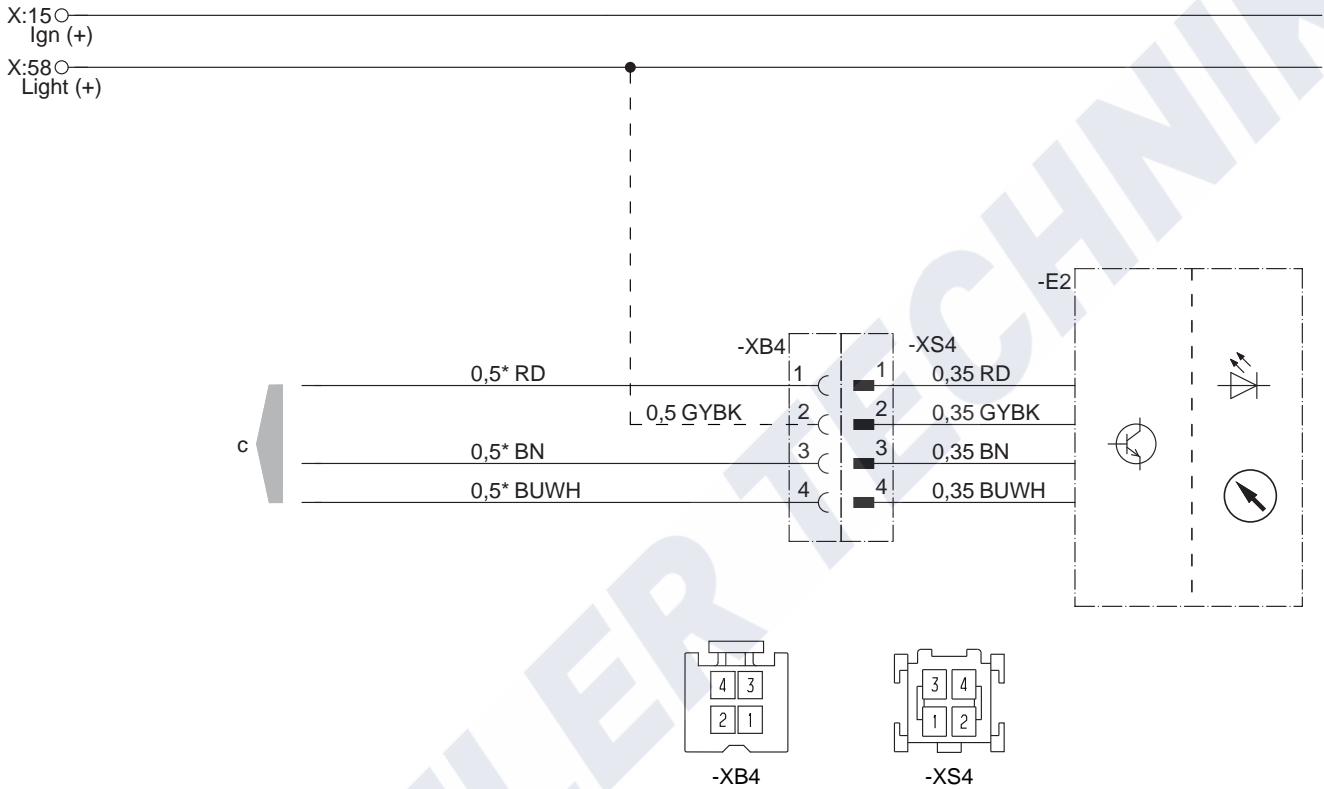

22 1000 34 97 34

Parts list

- E2 EasyStart Select
- c to the cable harness

Connectors and bush housings are shown from the cable inlet side.

i NOTE

Further circuit diagrams for the EasyStart Select are printed in the Installation Instructions Plus, these are available to view and download from the Service Portal.

5 ELECTRICS

CIRCUIT DIAGRAM, CONTROL UNIT – EASYSTART WEB

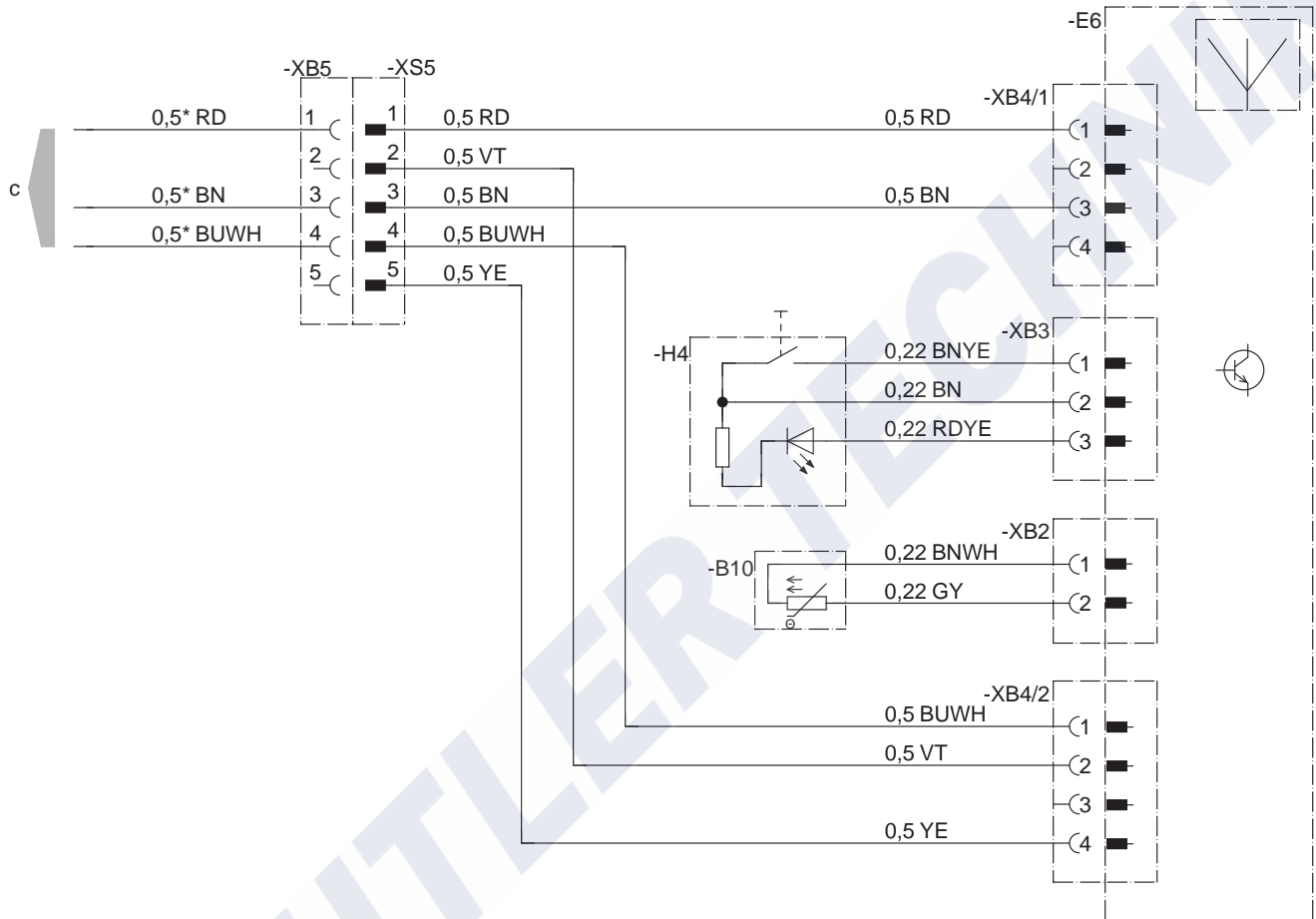

22 1000 34 97 18

Parts list

- B10 Room temperature sensor
- E1 EasyStart Web
- H4 Button
- c to the cable harness

Connectors and bush housings are shown from the cable inlet side.

6 TROUBLESHOOTING / MAINTENANCE / SERVICE

IF FAULTS OCCUR, PLEASE CHECK THE FOLLOWING ITEMS

- If the heater does not start after being switched on:
 - Switch the heater off and on again.
- If the heater still does not start, check whether:
 - Fuel in the tank?
 - The fuses are ok?
 - The electrical cables, connections, terminals, are ok?
 - Is the combustion air system or exhaust system blocked?

NOTE

Always ensure that there is sufficient fuel in the tank, as the heater switches to fault and locks if operated without fuel.

TROUBLESHOOTING

If, after checking these items, the heater is still faulty or another malfunction occurs in your heater, please contact:

- If factory-installed, your contract workshop / garage.
- If subsequently installed, the workshop / garage which installed the heater.

NOTE

Please note that guarantee claims can expire if the heater is modified by a third party or if non-original parts are installed.

MAINTENANCE INSTRUCTIONS

- Before the heating period starts, the heater should be put through a trial run. If thick, persistent smoke develops, unusual burning noises or a clear fuel smell occurs or if electric / electronic components overheat, the heater must be switched off and put out of service by removing the fuse. In this case, the heater should not be started up again until it has been checked by qualified staff who have been trained on Eberspächer heaters.
- Check the openings of the combustion air supply and exhaust system after longer standstills, clean if necessary!

SERVICE

If you have any technical questions or problems with your heater, dial the following service phone number from within Germany:

Hotline

Tel. 0800 / 12 34 300

Fax hotline

Tel. 01805 / 26 26 24

Outside of Germany, please contact the respective Eberspächer national representative, see <http://www.eberspaecher.com/en/worldwide.html>.

7 ENVIRONMENT

CERTIFICATION

The high quality of the Eberspächer products is the key to our success. To guarantee this quality, we have organised all work processes in the company along the lines of quality management (QM).

Even so, we still pursue a large number of activities for continuous improvement of product quality in order to keep pace with the similarly constantly growing requirements made by our customers.

All the steps necessary for quality assurance are stipulated in international standards.

This quality is to be considered in a total sense.

It affects products, procedures and customer / supplier relationships.

Officially approved public experts assess the system and the corresponding certification company awards a certificate.

Eberspächer has already qualified for the following standards:

**Quality management in accordance with
EN ISO 9001:2008 and ISO/TS 16949:2009**

**Environmental management system in accordance with
EN ISO 14001:2004**

DISPOSAL

DISPOSAL OF MATERIALS

End-of-life devices, defect components and packaging material can all be separated and sorted into pure-grade fractions so that all parts can be disposed of as required in an environment-friendly manner recycled where applicable.

Electric motors, control boxes and sensors (e.g. temperature sensors) are deemed to be “electronic scrap”.

DISMANTLING THE HEATER

The heater is dismantled according to the repair stages in the current troubleshooting / repair instructions.

PACKAGING

The packaging of the heater can be kept in case the heater has to be sent back.

EU DECLARATION OF CONFORMITY

We herewith declare that the version of the heater placed on the market by us conforms to the applicable provisions of the following EC Directives.

EC Directive 2011/65/EU

EC Directive 2014/30/EU



The full Declaration of Conformity can be viewed and downloaded from the download centre under www.eberspaecher.com.

8 INDEX/LISTS

INDEX

A

- Accident prevention [9](#)
- Arrangement of the heater [7](#)
- Automatic control [7](#)

B

- Before switching on [28](#)

C

- Certification [39](#)
- Check in case of faults [38](#)
- Circuit diagram, cable harness [32](#)
- Circuit diagram, control unit – EasyStart Web [37](#)
- Circuit diagram, control unit – EasyStart R [35](#)
- Circuit diagram, control unit – EasyStart R+ [34](#)
- Circuit diagram, control unit – EasyStart T [33](#)
- Combustion air intake [7](#)
- Combustion air system [23](#)
- Concept of this manual [5](#)
- Control and safety devices [29](#)
- Cooling water circuit [18 – 21](#)

D

- Dismantling the heater [39](#)
- Disposal [39](#)
- Disposal of materials [39](#)

E

- EC Declaration of Conformity [39](#)
- Emergency stop [29](#)
- Emergency stop – EMERGENCY OFF [29](#)
- Environmental management system [39](#)
- Exhaust system [7, 22](#)

F

- Fax hotline [38](#)
- Fuel quality for diesel heater [27](#)
- Fuel quality for petrol heater [27](#)
- Fuel supply [7, 24 – 29](#)
- Fuel withdrawal with tank connection [25](#)
- Functional description [28](#)
- Fuse bracket [17](#)

H

- Hazard information and safety instructions [8](#)
- Heater circuit diagram [31](#)
- Heater installation position [15](#)
- Heater scope of supply [10](#)
- Heater wiring [30](#)
- Heating at high altitudes [28](#)
- Heating mode [28](#)
- Hotline [38](#)

I

- Important information [6](#)
- Initial commissioning [28](#)
- Installation [8](#)
- Installation and fixing – heater [17](#)
- Installation example [16](#)
- Installation kit scope of supply [10](#)
- Installation location [16](#)
- Installation position of the metering pump [26](#)
- Installation steps [17](#)
- Installing the combustion air system [23](#)
- Installing the exhaust system [22](#)
- Instructions for operation [28](#)
- Intended use [6](#)

L

- List of abbreviations [41](#)

M

- Main heater dimensions [14](#)
- Maintenance instructions [38](#)

N

- Nameplate [17](#)

O

- Operating instructions [28](#)
- Operation [8](#)

P

- Packaging [39](#)
- Parking ventilation [28](#)
- Parts list [30](#)
- Permissible installation positions [15](#)
- Permissible line lengths [25](#)
- Permissible suction and pressure head [26](#)
- Picture symbols [6](#)

Q

- Quality management [39](#)

S

- Safety check [28](#)
- Scope of supply [10, 11](#)
- Service [38](#)
- Special text formats [6](#)
- Statutory regulations [7](#)
- Switching on [28](#)

T

- Technical data for the diesel heater [13](#)
- Troubleshooting [38](#)

W

- Water pump installation position [15](#)

8 INDEX/LISTS

LIST OF ABBREVIATIONS

ADR

European Agreement concerning the International Carriage of Dangerous Goods by Road.

ECE regulation

Internationally agreed, uniform technical specifications for vehicles, parts and equipment of motor vehicles.

EMC directives

Electromagnetic compatibility.

FAME

Biodiesel to EN 14214.

Eberspächer partner

J. Eberspächer partner.

BUTLER TECHNIK

BUTLER TECHNIK

BUTLER TECHNİK

Eberspächer Climate Control Systems
GmbH & Co. KG
Eberspächerstraße 24
73730 Esslingen
Hotline: 0800 1234300
Fax hotline: 01805 262624
info@eberspaecher.com
www.eberspaecher.com

