

Webasto Product UK

Thermo Top C300
Diesel Hot water Heating System

Plate Heat Exchanger

Basic Installation notes

Webasto Product UK Ltd

White Rose Way
Doncaster Carr
Doncaster
South Yorkshire
DN4 5JH

Phone: 01302 322232
Fax: 01302 322231

Basic Installation guidelines for TTC300 Plate Heat exchanger/Heating system

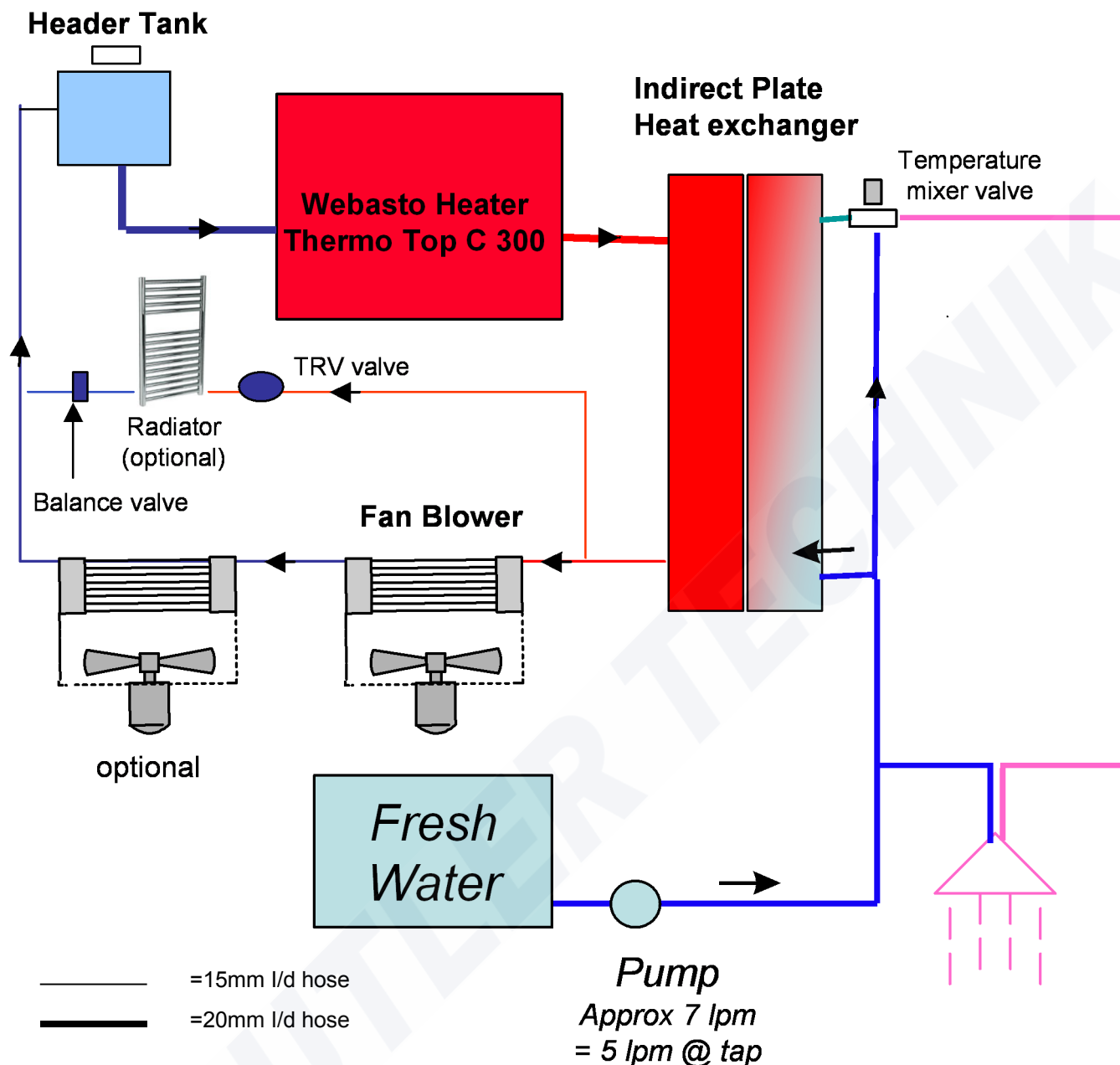

Overview of coolant circuit

Thermo Top C 300

This installation uses an independent self contained coolant system to provide heating and hot water.

This is achieved very quickly due to a small coolant circuit being used which has a very quick warm up time, the hot water is produced via a plate heat exchanger therefore the hot water is ready in around 5 minutes.

The Webasto heater is mounted externally on the vehicle, whilst the header tank and plate heat exchanger utilise minimal interior space. The blower units would be mounted in the area where the heat is most required i.e. living area and the rear. These 2 x 2 speed blowers shown in the diagram, can operate independently or together & are controlled by a thermostat. Heating & hot water on the move is possible.

Basic Installation guidelines for TTC300 Plate Heat exchanger/Heating system

● *Thermostatic Rad Valve (TRV)*

● *Radiator balance valve*

— = 15mm I/d pipe

— = 20mm I/d pipe

— = Hot Feed

— = Return flow

— = Fresh water - cold

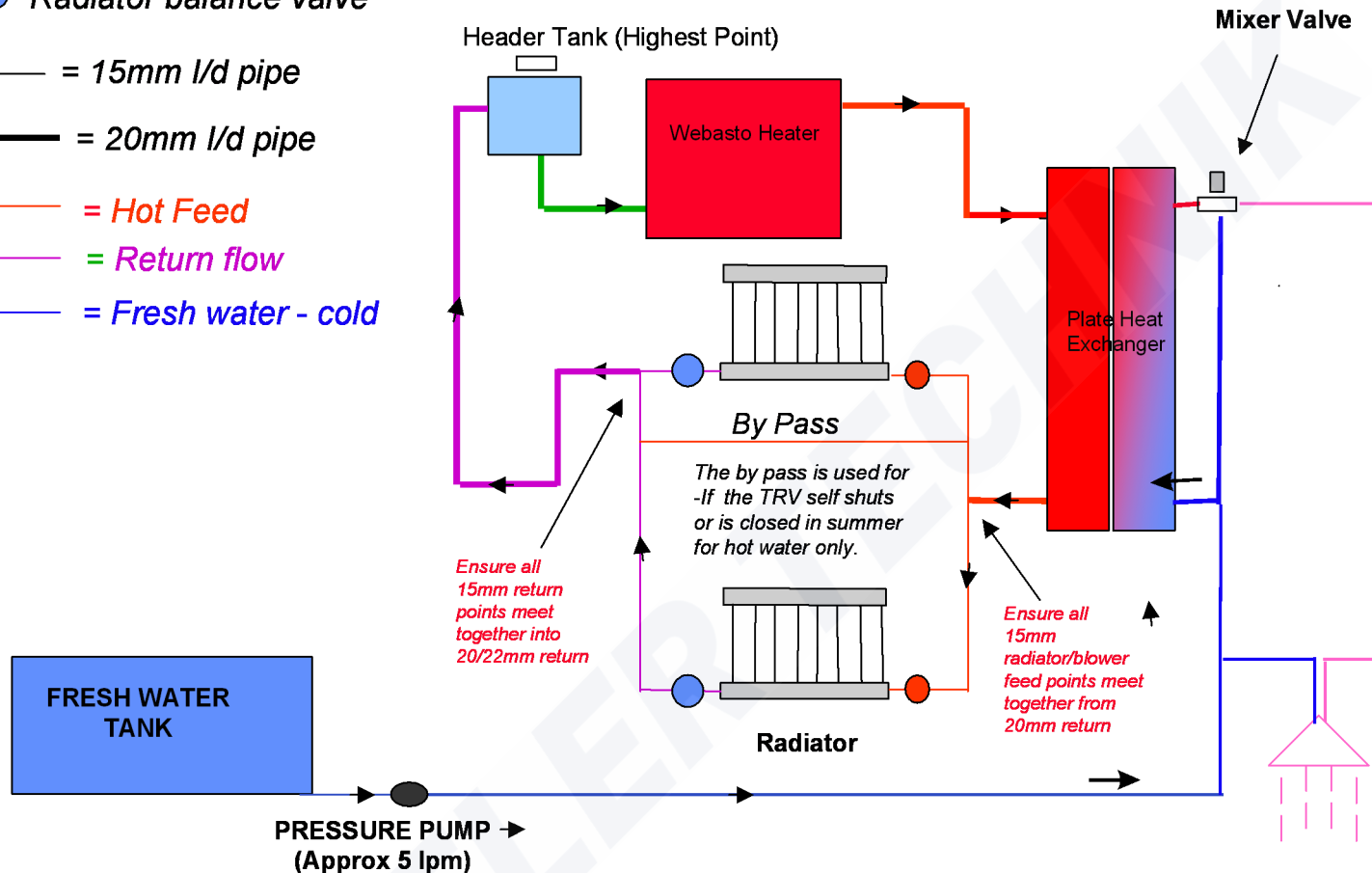

Radiator Circuit

A radiator circuit can be used. TRV valves are recommended to control the heat output. The balance valves ensures the flow is distributed evenly. A bypass must be incorporated to ensure a constant coolant flow for when either the TRV valves shut off when temperature is reached or when the valves are manually closed in summer for no heating/hot water only. A simple on/off switch is all that is needed to control the heater. The bypass could be made by incorporating a blower box.

Basic Installation guidelines for TTC300 Plate Heat exchanger/Heating system

Header Tank

The header tank is mounted internally in a place easily accessed in order to fill & check the coolant level. It should also be above the Webasto heater & ideally the highest point in the system. This will aid bleeding of air from the system. Consideration should be given that the hose to feed the heater (20mm I/d) & the coolant return hose (15mm I/d) can be routed to & from the tank to their relevant connection points. The different ports are drilled to suit coolant feed into the heater & return. Coolant feed is taken from a lower port. The return can be via the 2nd underneath port or side ports. When drilling use a suitable size hole saw. Ensure all plastic drillings are thoroughly cleaned out of the tank. An antifreeze mixture similar as recommended for the vehicle engine depending on climate conditions is recommended.

THE TANK CAN BE FILLED TO A HIGHER LEVEL THAN THE MAXIMUM. PROVIDING THE OVERFLOW PIPE IS INSTALLED, THE COOLANT WILL FIND ITS OWN LEVEL TO SUIT THE SYSTEM CAPACITY.

The tank shown below is not pressurised so fill the tank as full as possible. Ensure the overflow pipe is installed & allow the coolant expansion to find its own level. The vertical mounted position is the most desirable.

NOTE: if the header tank is mounted close to the sleeping area then consider installing the header tank so the coolant return pipe is below the coolant level. This can give a quieter effect of movement of coolant, than if the returning coolant is running on top of the coolant.

Return the coolant return below the coolant if possible (not mandatory) it will be quieter.

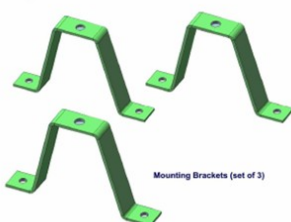
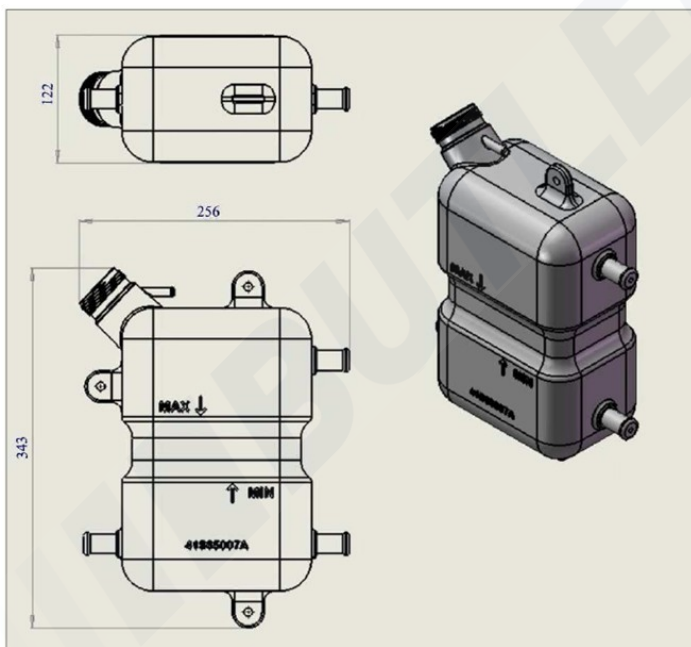

Tank can be mounted vertically or horizontally with left or right fill



Basic Installation guidelines for TTC300 Plate Heat exchanger/Heating system

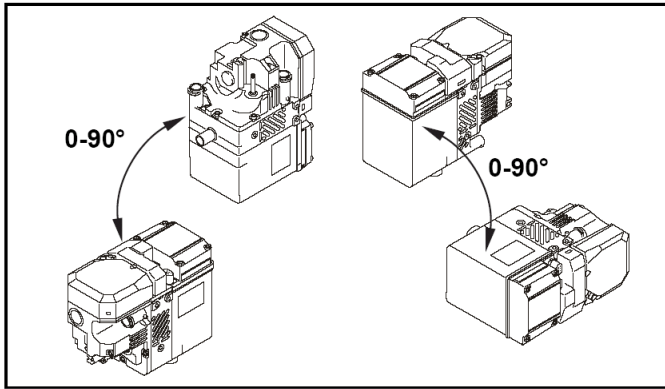

The heater is generally mounted externally & underneath the vehicle floor in a dry splash proof area. The heaters coolant pump will be lower than the coolant supplied by the header tank. This is so that the coolant pump always has a head of coolant as it is not self priming. Follow the guidelines as laid out in the general installation manual. Give consideration to the hose route from coolant tank to water pump inlet & coolant out to the plate heat exchanger. The heater is mounted to its mounting bracket using the 3 grey coloured self cutting screws. Lubricate these prior to installing. The bracket can be installed either side.

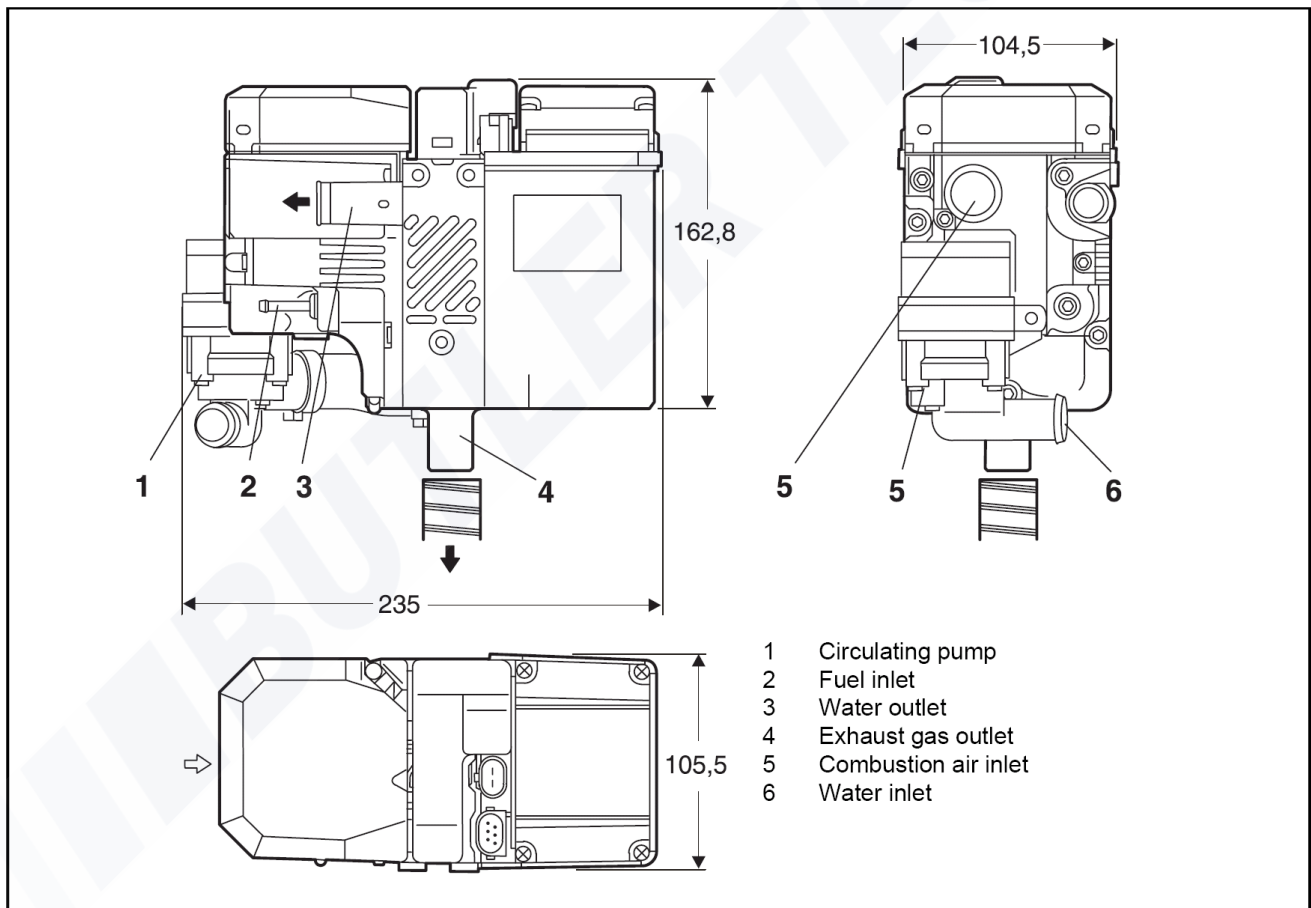

Basic Installation guidelines for TTC300 Plate Heat exchanger/Heating system

Plate heat exchanger

The plate heat exchanger is generally fitted inside the vehicle. A version with drain is available should the unit be mounted externally. It can be mounted anywhere within the coolant circuit. The nearer the taps the less cold water needs to be run before hot water is at the taps. The mixer valve has a hot water temperature adjustment knob. It should be mounted so this is accessible for initial adjustment. The fresh water connections are 1/2" Bsp.

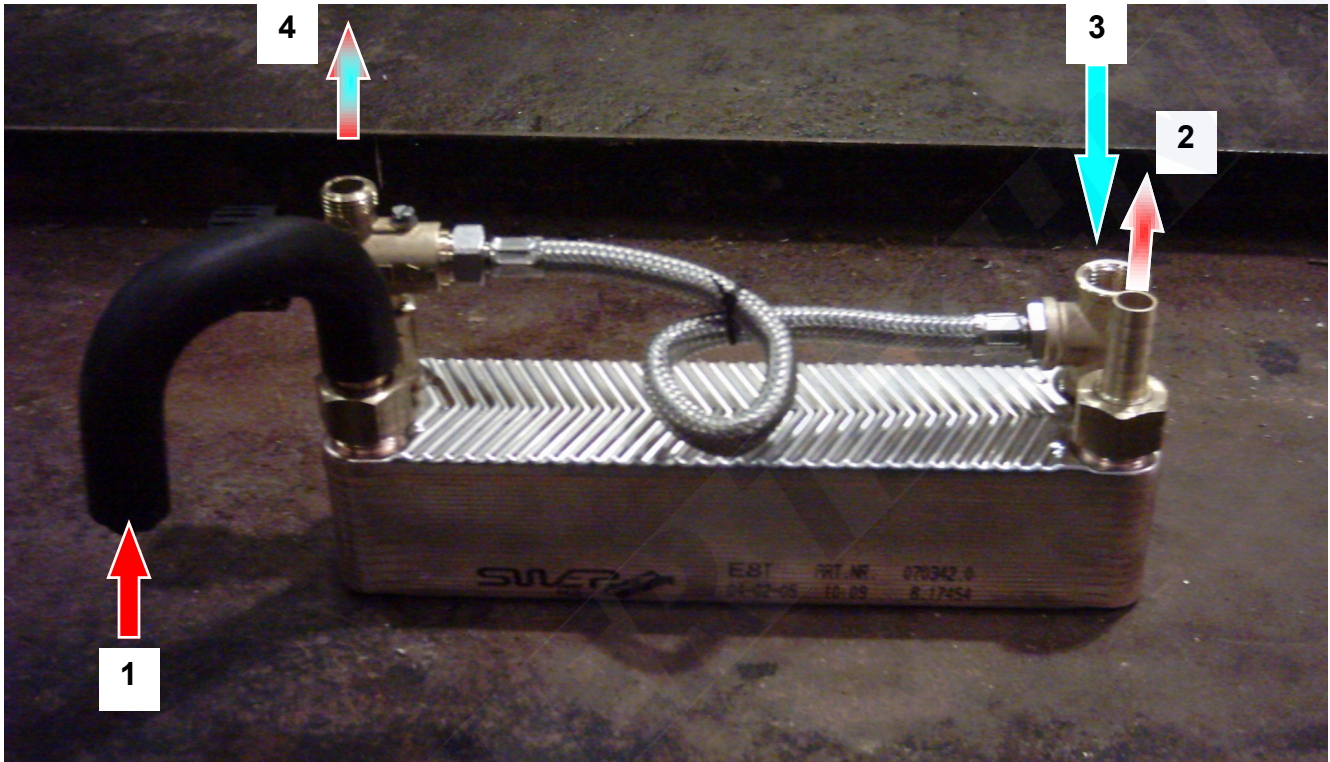

1. Webasto Heater – Hot coolant in 20mm.
2. Webasto circuit out to rear blowers 15mm.
3. Cold fresh water in from pump.
4. Hot mixed out to showers.

Consider mounting a plate heat exchanger in a way that allows water drainage in winter. For example you would place T on the water feedline with a drainage tap.



Important—When fitting the relevant 1/2" bsp fresh water connections ensure that the fittings are tightened using 2 correct spanners. 1 to hold the stationary fitting & 1 to tighten the loose fitting. Failure to do so may loosen the fittings on the plate heat exchanger & cause water leaks. The fresh water connections are fitted with a thread lock seal. Disturbance of this seal results in leaks. & will have to be remade.

Basic Installation guidelines for TTC300 Plate Heat exchanger/Heating system

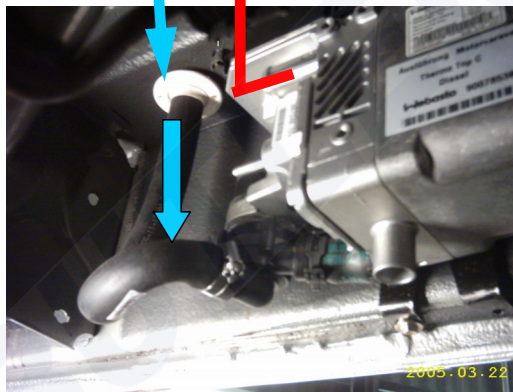
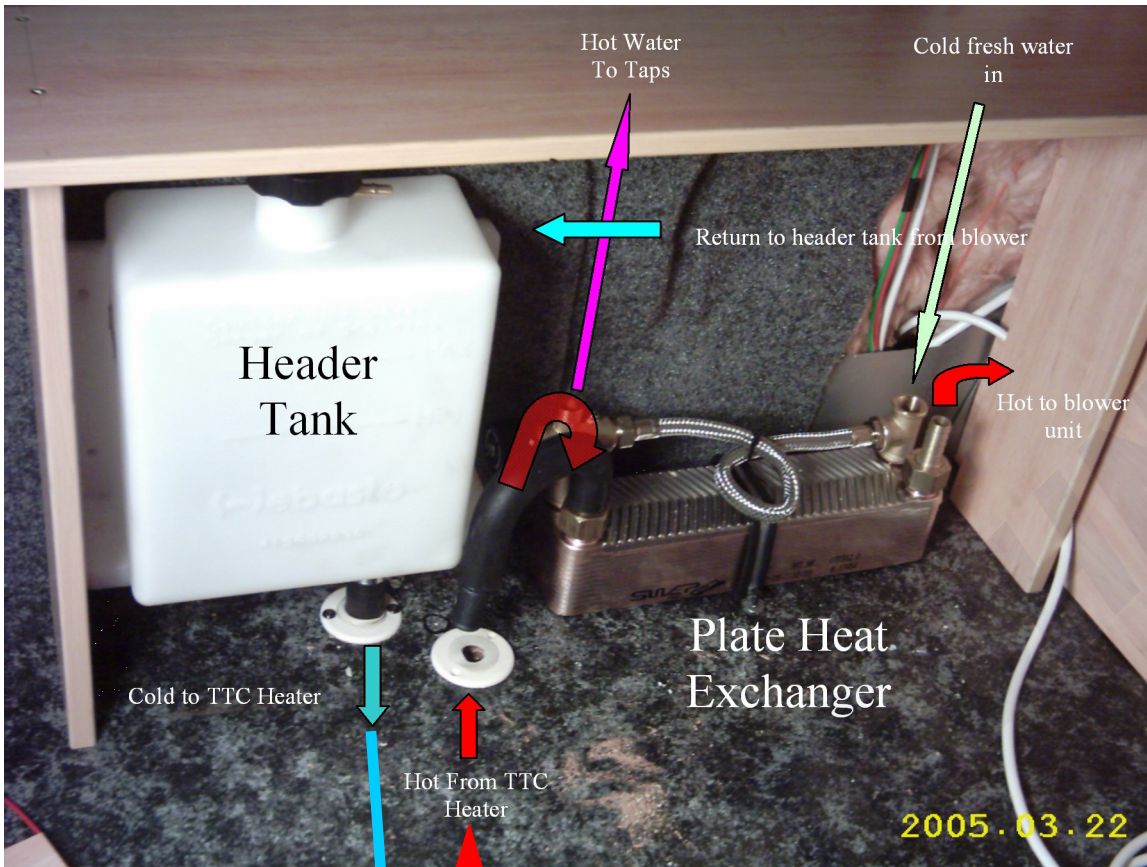

Thermo Top C 300

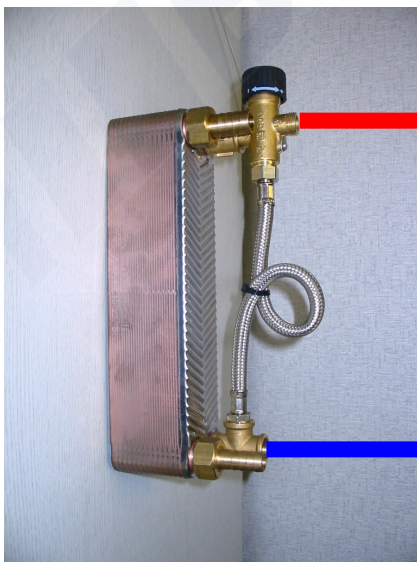

If you are installing the plate heat exchanger without drain, consider how the water can be drained when not in use for cold weather frost protection. The plate heat exchanger can be mounted in several orientations. A vertical example as shown should allow drainage of water

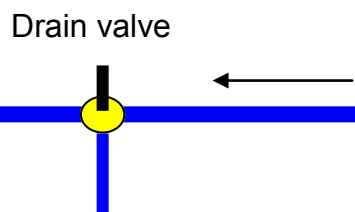

Basic Installation guidelines for TTC300 Plate Heat exchanger/Heating system

Blower Boxes

Generally 1 or 2 x Silencio 2 blower boxes are installed to distribute heat from the coolant circuit into the vehicle. The Silencio 2 has a double coil heat exchanger which ensures that the flow of the heating circuit does not have a restricted flow. Two of these blowers can be mounted within an in line circuit. This also aids bleeding of the heating circuit. The blower boxes are generally mounted as near to the area that requires heating as possible. It is preferential to blow straight from the grill fascia. In some applications it may be necessary to distribute the heat via a ducting system to the areas required. In this case distance of ducting & heat losses must be considered. Wherever the blower box is mounted it must be ensured that sufficient airflow can be drawn in. The cross sectional area should be equal or greater that the air out.

The intake volume of recirculation air is important.. Eg the Silencio 2 blower = 2 fans moving a volume of 2 x 250cm³ per hour.

The air drawn through is re circulated. This = a quicker warm up time. Ensure sufficient ventilation is made.

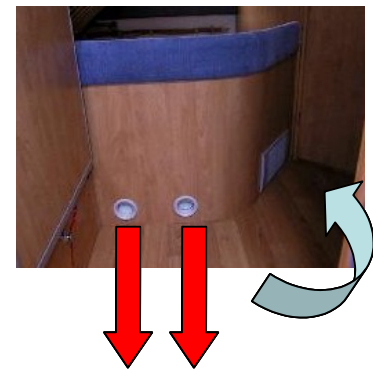
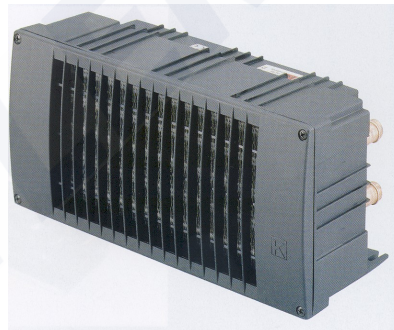

Rated Voltage	v	12v
Rated Heat Output	kW	5.5kW
Maximum Heated Airflow	m ³ /hr	250
Electrical Input	W	16
Noise Level	dB	46
Weight	kg	2
Hose Connection	mm	16 (22mm available on special order)



Optional 3 spigot duct plate

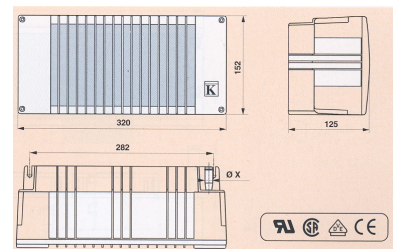

Important—Remove the blanking seals installed in the heater matrix before connecting the coolant hoses.

Basic Installation guidelines for TTC300 Plate Heat exchanger/Heating system



Basic Installation guidelines for TTC300 Plate Heat exchanger/Heating system

Fuel

The fuel pump is mounted near to the fuel supply, generally within around 1 metre.

Take notice of the type of fuel pump supplied & its mounting requirements. Further information can be found within the installation guidelines.

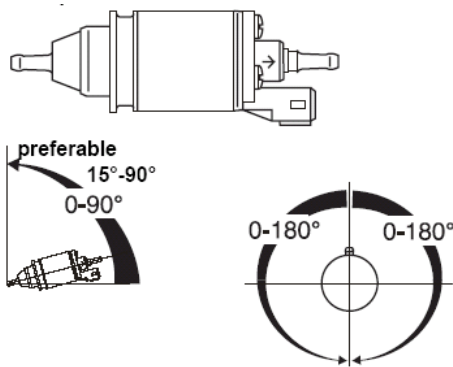

DP2 Fuel pump. Note conical end

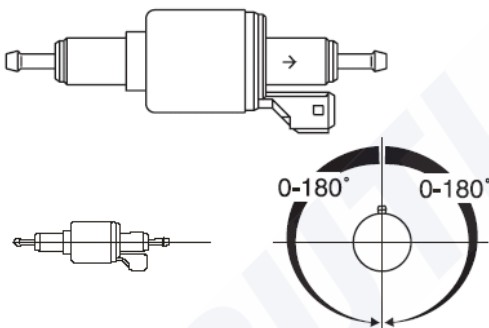

DP30 Fuel pump.

The following components installation detail can be found within the general installation handbook

- Exhaust
- Fuel connection—Also see Webasto UK fuel integration guidelines for different vehicles.
- Combustion air pipe.

Basic Installation guidelines for TTC300 Plate Heat exchanger/Heating system

Thermostat

The thermostat is used to control the temperature in the living cell. It will switch the blower box on or off depending on the temperature sensed by the Thermostat. Do not install behind an obstruction ie curtains or close to a heat source ie cooker etc.



Basic Installation guidelines for TTC300 Plate Heat exchanger/Heating system

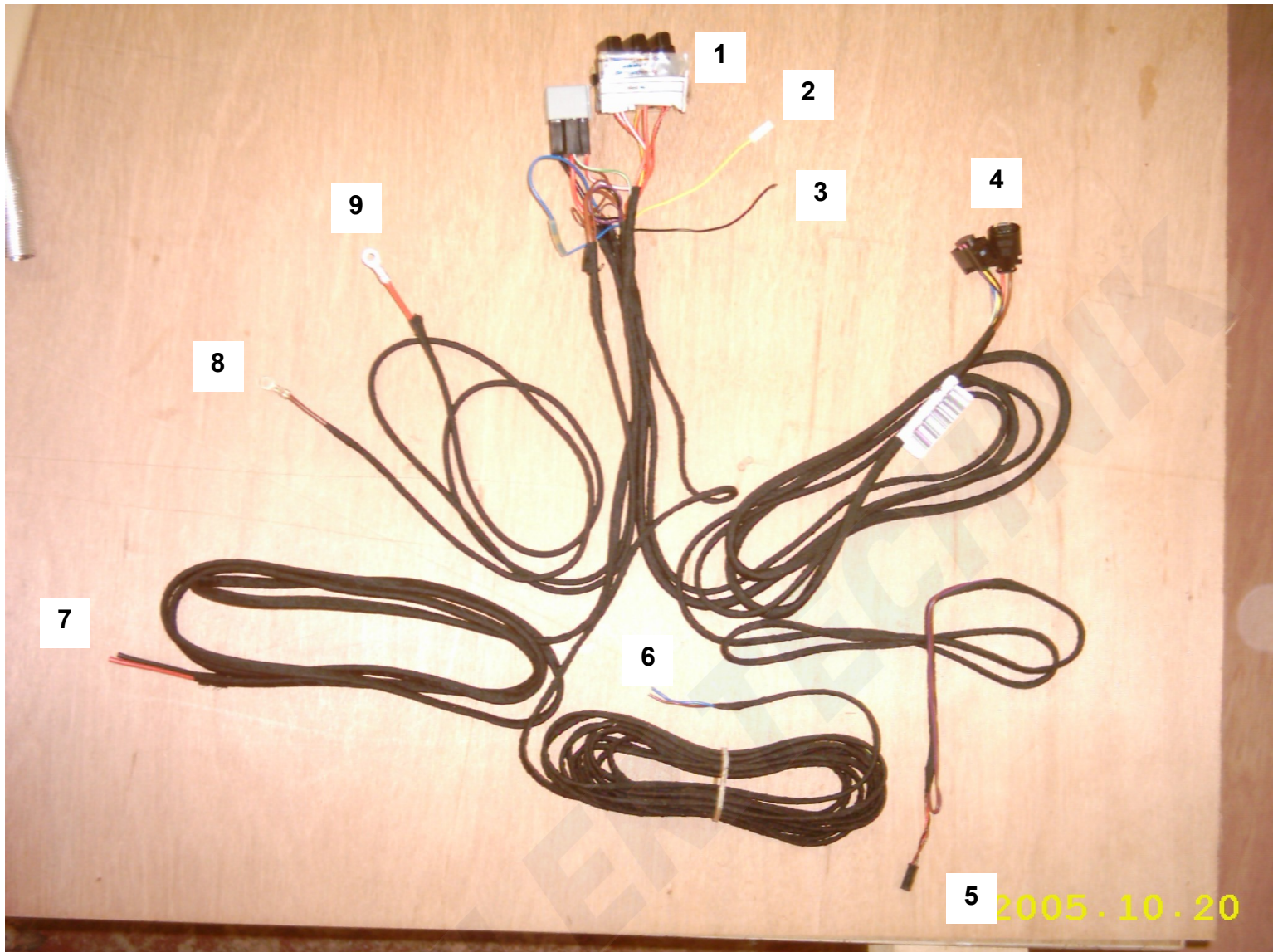

1. Fuse box
2. Diagnostic signal—Yellow—used for PC diagnostics.
3. Pin 3 cable—black. This is used to trigger the heater from the switch panel.
4. Heater main plugs—2 way & 6 way.
5. Timer plug—4 way. Allows plug N play of programmable timer, remote control or Ther-mocall to allow preheating of system.
6. Fuel pump cable—brown & blue .5mm cable. Connect either way round in plug.
7. Fan trigger—Connected to relay. This allows independent switch on of blower fans if preheating option is used. Black & red 2.5mm cable.
8. Earth—brown — brown 2.5mm. Requires permanent connection to leisure battery. Do not lengthen cables.
9. Positive 12volts — red 2.5mm. Requires permanent connection to leisure battery. Do not lengthen cables.

Basic Installation guidelines for TTC300 Plate Heat exchanger/Heating system

Using The Short Harness

1. Your harness
2. connection point
3. Fuel pump plug

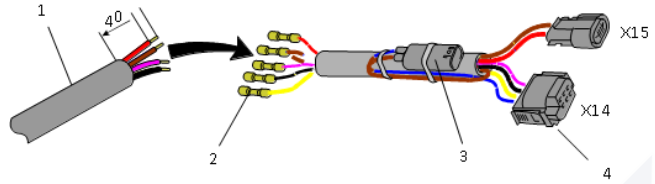

If using this, you will feed a fused pos & neg using at least **4mm** thinwall & a single 1mm thinwall switched feed signal. Failure to use correctly dimension cable will result in voltage drop issue. Importantly the harness p/n is 4111373A which means the pin 3 modification has already been done.

Here use the following cables

- Red +ve
- Brown -ve
- Black +ve on signal from switch device
- Green/white not used
- Yellow = diagnostics

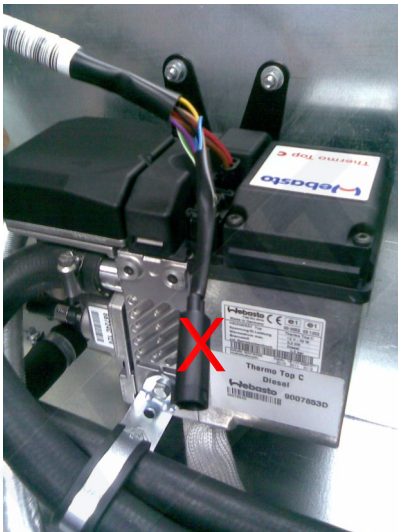
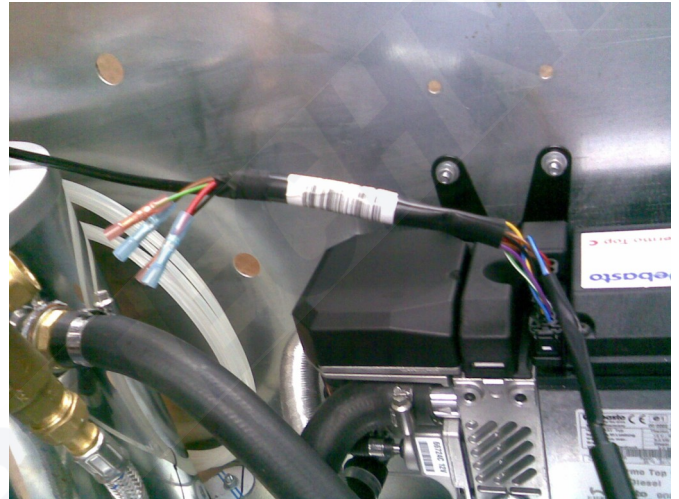

The remaining flylead contains the diagnostic cable. The brown & purple are not used.



Basic Installation guidelines for TTC300 Plate Heat exchanger/Heating system



Water Pump Relay

The waterpump relay is used to switch off the blowers when water is being run at the taps. This allows full energy for hot water production & prevents the blowers cooling down. The connection of the relay trigger wire is made at the pressure switch at the side that feeds power to the pump motor.

Basic Installation guidelines for TTC300 Plate Heat exchanger/Heating system

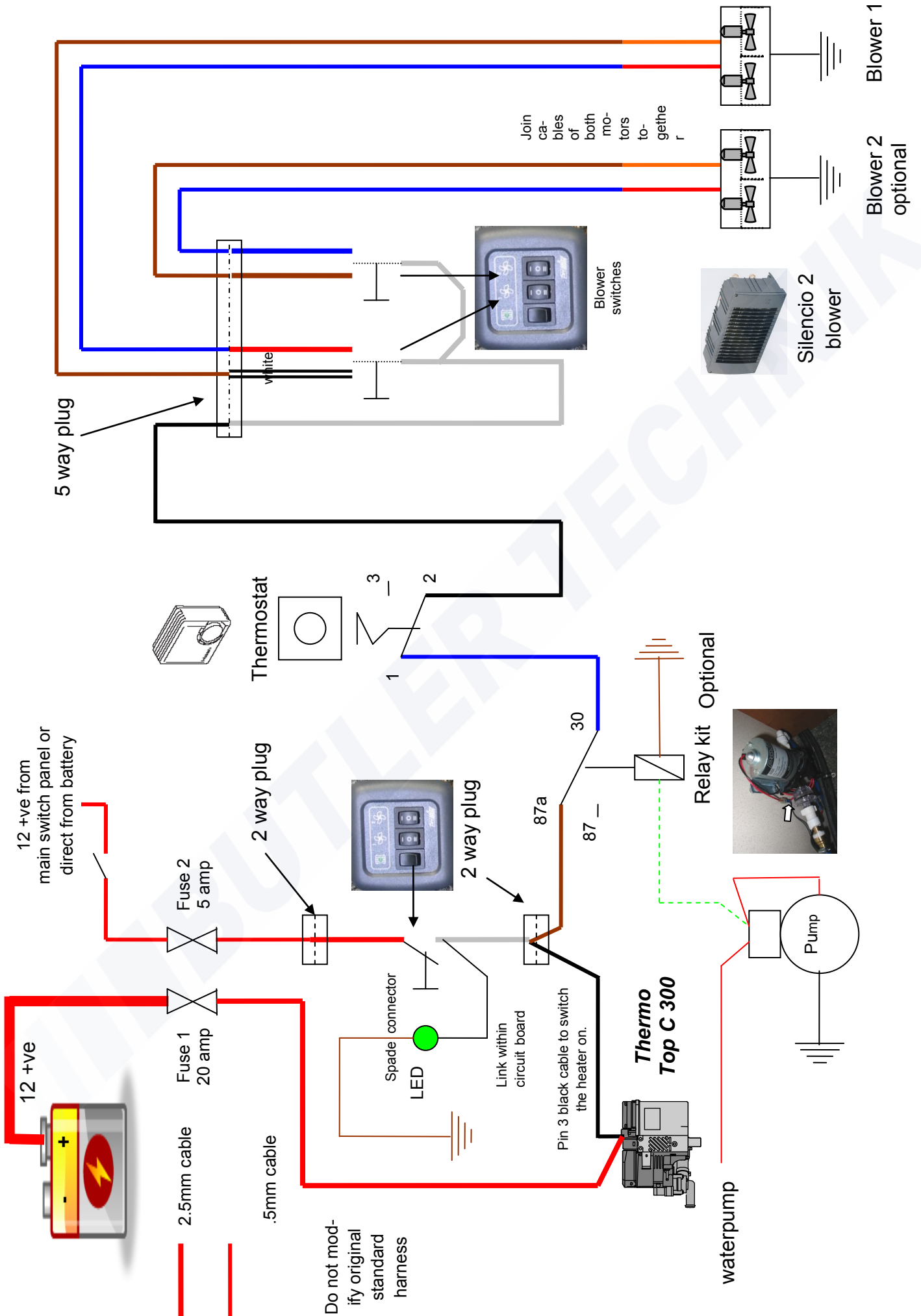

The following notes are intended as a guide only and are not binding