

**Wasserheizgerät
Water Heater**

**Einbauanweisung
Installation Instructions
Thermo Top Evo**

Thermo Top Evo - B (Benzin / Petrol / 汽
油) Thermo Top Evo - D (Diesel / 柴油)

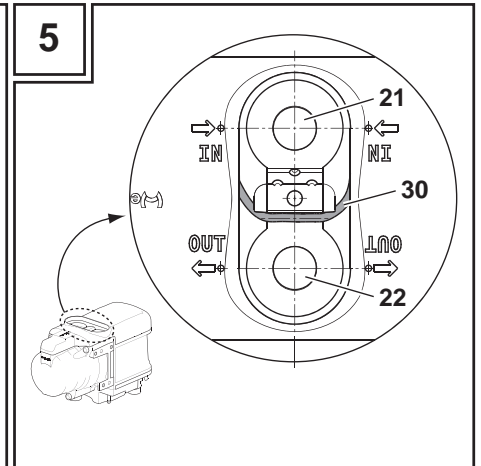

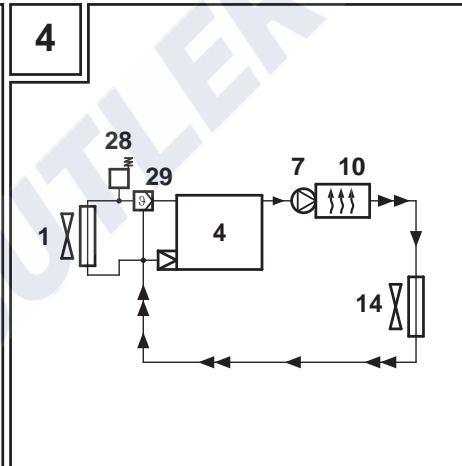
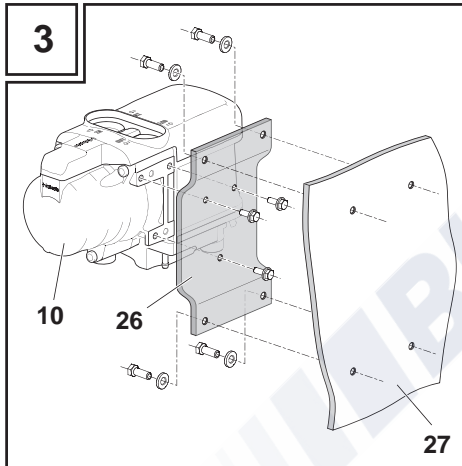
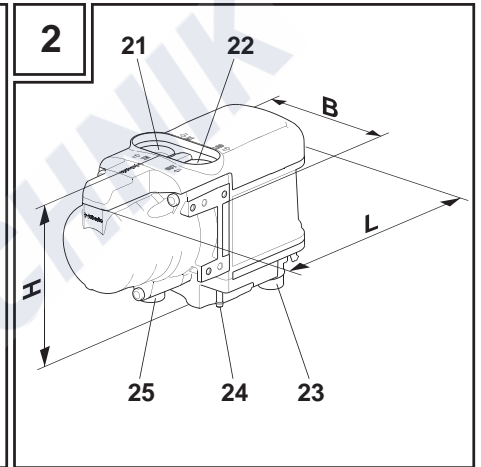
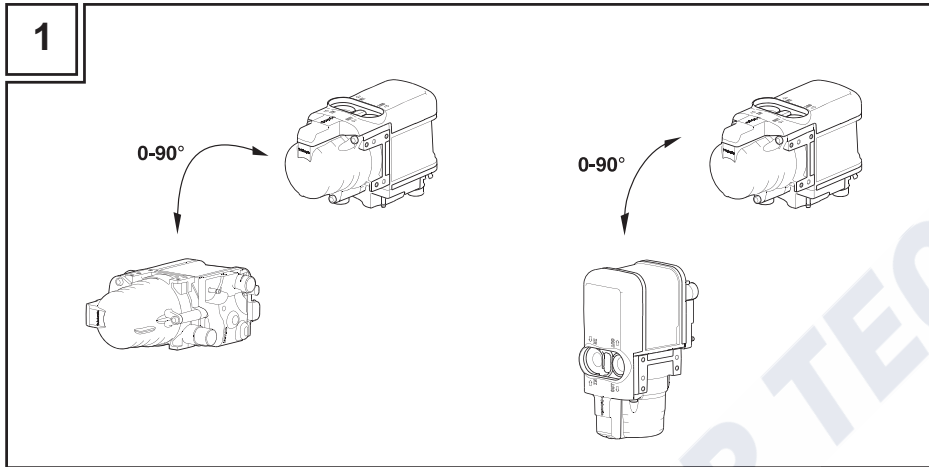

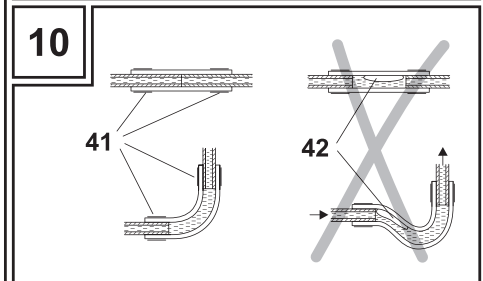
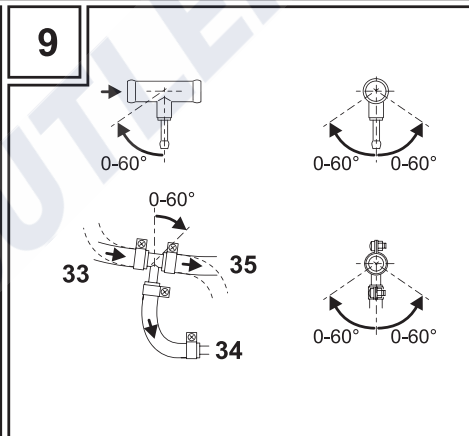
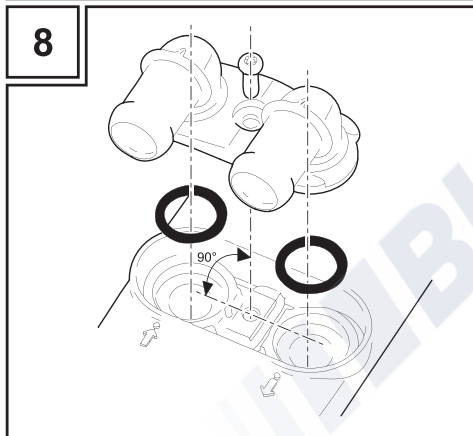
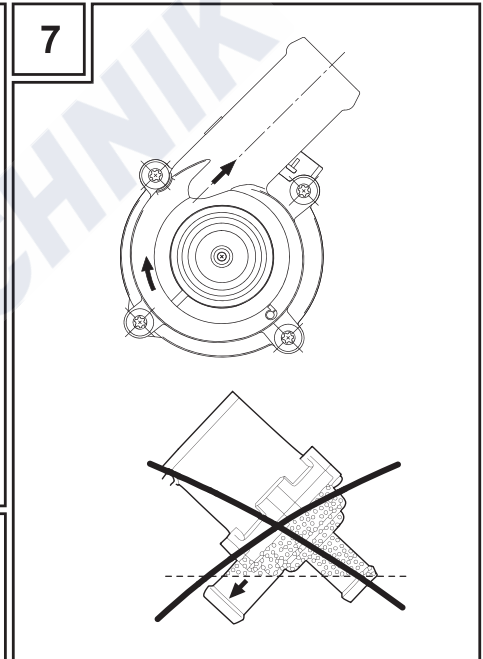
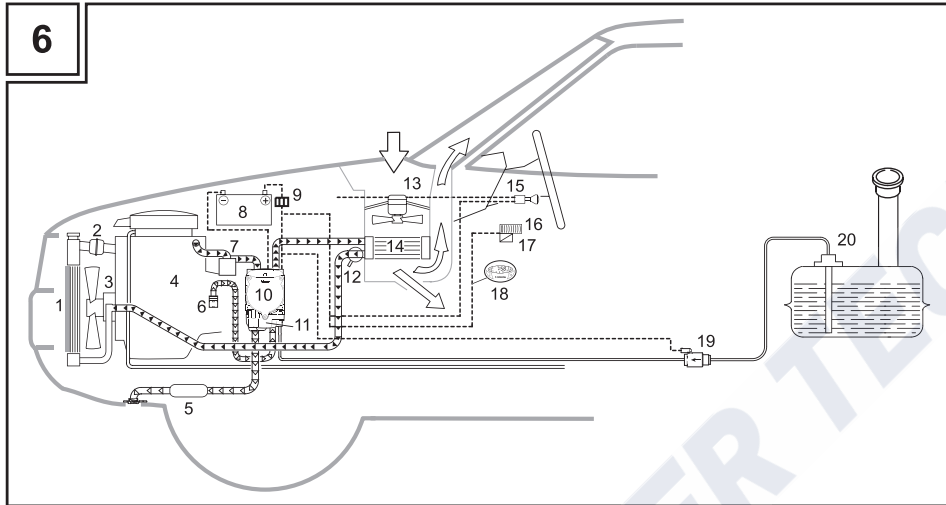

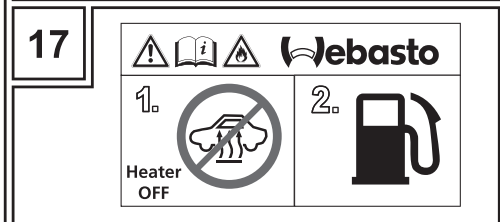
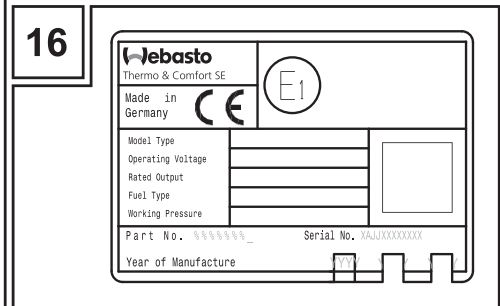
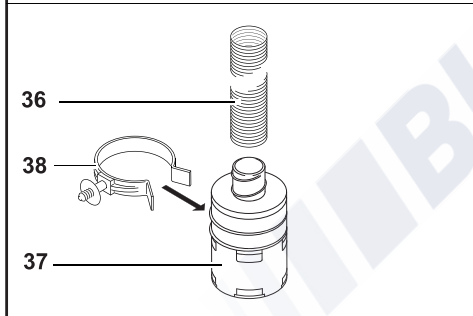
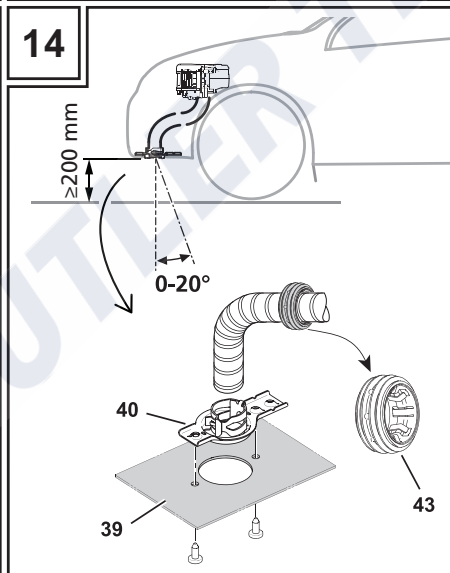
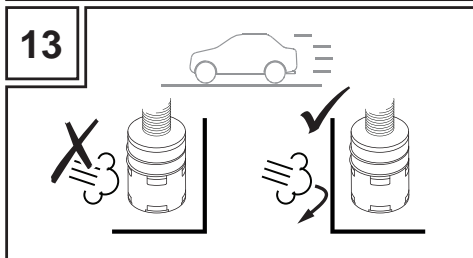
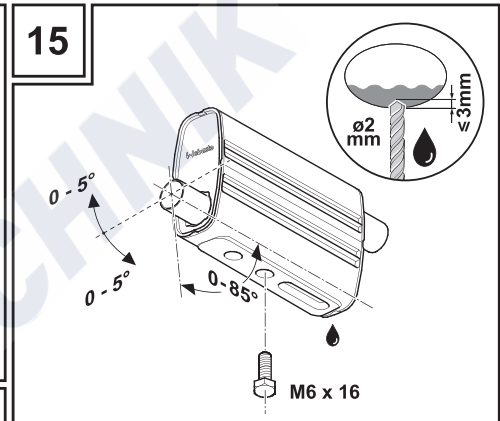
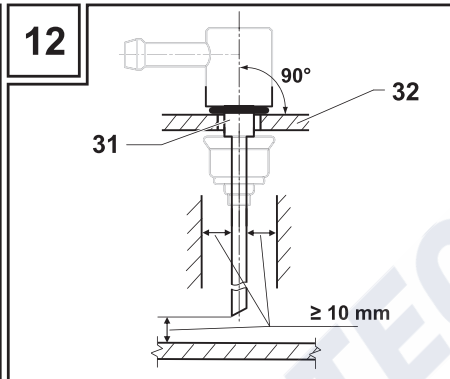
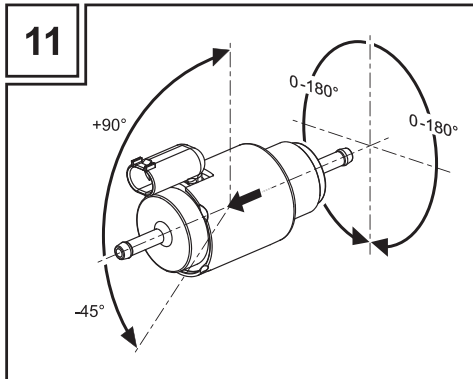



Improper installation or repair of Webasto heating and cooling systems can cause fire or the leakage of deadly carbon monoxide leading to serious injury or death.

To install and repair Webasto heating and cooling systems you need to have completed a Webasto training course and have the appropriate technical documentation, special tools and special equipment.

Only genuine Webasto parts may be used. See also Webasto air and water heaters accessories catalogue.



NEVER try to install or repair Webasto heating or cooling systems if you have not completed a Webasto training course, you do not have the necessary technical skills and you do not have the technical documentation, tools and equipment available to ensure that you can complete the installation and repair work properly.

ALWAYS carefully follow Webasto installation and repair instructions and heed all WARNINGS.

Webasto rejects any liability for problems and damage caused by the system being installed by untrained personnel.

GB Table of Contents

1	Regulations governing installation.....	2	9	Combustion air supply.....	11
	1.1. Statutory regulations governing installation	2		9.1. Combustion air pipe.....	11
	1.2. Additional documentation to be used	2		9.2. Intake silencer.....	11
				9.3. Notes on installation	11
2	Use / version	3	10	Exhaust System	12
	2.1. Use of the water heaters.....	3		10.1. Exhaust pipe	12
	2.1.1. Parking heater.....	3		10.2. Exhaust silencer.....	12
	2.1.2. Auxiliary heater	3		10.3. Recommendations for installation	12
	2.2. Version	3	11	Electrical Connections	14
3	Installation location and installation position.....	4		11.1. Connecting control unit/heater	14
4	Type label	5		11.2. Connecting circulation pump	14
5	Standard bracket.....	5		11.3. Installation and connection of the timer.....	14
6	Example of Installation in a Passenger Car.....	5		11.4. Installation of other heater controls	14
7	Integration in Coolant System	6		11.5. Vehicle blower	14
	7.1. Connection	6	12	Wiring diagrams.....	15
	7.2. Installing coolant connection pieces	6	13	Initial start-up.....	17
	7.3. Installing coolant hoses	7	14	Technical Data	18
	7.4. Installing circulation pump	7		14.1. Technical Data for Thermo Top Evo.....	18
	7.5. Checking.....	7		14.2. Technical data of circulation pump.....	18
8	Fuel integration.....	8			
	8.1. Integration in engine supply or return line.....	8			
	8.2. Integration via vehicle's own fuel delivery unit	8			
	8.3. Fuel line	8			
	8.3.1. Line installation	9			
	8.3.2. Line design.....	9			
	8.3.3. Connecting two lines with a hose	9			
	8.3.4. Metering pump.....	9			
	8.3.5. Installation location.....	9			
	8.3.6. Installation and attachment.....	9			
	8.4. Label.....	10			
	8.5. Cold-resistant fuels.....	10			

Explanatory Notes on Document

To provide you with a quick overview of the individual working steps, you will find an identification mark on the outside top corner of the page in question. Sections in italics contain an excerpt from the Directive ECE-R 122.

Mechanical system

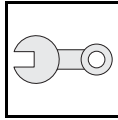

Electrical system

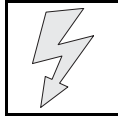

Coolant circuit



Fuel



Exhaust gas

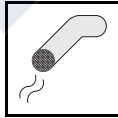

Combustion air

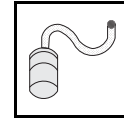

Technical information



Caution



Note

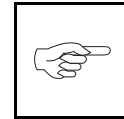



1 Regulations governing installation

1.1. Statutory regulations governing installation

Type approvals according to ECE-R 10 (EMC) and ECE-R 122 (Heater) exist for the Thermo Top Evo heater.

See chapter 14, "Technical Data" for the approval number.



The provisions of these Directives are binding within the territory governed by EU Directive 70/156/EEC and/or EC/2007/46 (binding for new vehicle types as of 29/04/2009) and should also be observed in countries in which there are no special regulations!



Failure to follow the installation instructions and the notes contained therein will lead to all liability being refused by Webasto. The same applies if repairs are carried out incorrectly or with the use of parts other than genuine spare parts. This will result in the invalidation of the type approval for the heater and therefore of its homologation/ECE type approval.

1.2. Additional documentation to be used

These installation instructions do not contain all necessary information and instructions with regard to the installation of Thermo Top Evo heaters. In addition, the operating instructions must also be used.



2 Use / version

2.1. Use of the water heaters

2.1.1. Parking heater

The Thermo Top Evo water heaters were designed for installation in Class M1 motor vehicles. Installation in Class O, N2 and N3 motor vehicles and vehicles for transporting hazardous substances is not permissible. When installing in special vehicles, the applicable regulations must be taken into account. Other uses are possible in consultation with Webasto.

The Webasto Thermo Top Evo water heater is used in conjunction with the original vehicle heating system

- to heat the passenger compartment,
- to defrost the vehicle windows,
- to preheat water-cooled engines (if technically possible).

The water heater operates independently of the vehicle engine and is integrated in the vehicle's cooling system, fuel system and electrical system.

2.1.2. Auxiliary heater

The water heater operates in dependence on the vehicle engine and is integrated in the vehicle's cooling system, fuel system and electrical system.

When the engine is switched off, the water heater is automatically also switched off and the fuel supply is cut off within 5 seconds.

2.2. Version

Thermo Top Evo - D

Water heater for "diesel" fuel.

Thermo Top Evo B

Water heater for "petrol" fuel.

The Thermo Top Evo water heater is designed for 12 V operation.

See chapter 14, "Technical Data" for the technical design.



Thermo Top Evo 5+ heater versions must not be used for island coolant system applications.



3 Installation location and installation position

Body sections and any other components in the vicinity of the heater must be protected from excessive heat and the possibility of fuel or oil contamination.

(Requirement from ECE-R 122, Point 5.3.2.1.).

The heater shall not constitute a risk of fire, even in the case of overheating. This requirement shall be deemed to be met if the installation ensures an adequate distance to all parts and suitable ventilation, by the use of fire resistant materials or by the use of heat shields.

(Requirement from ECE-R 122, Point 5.3.2.2.).

The heater must not be installed in the vehicle interior. The heater is preferably installed in the engine compartment, i.e. in the area between the wheel well and the front bumper.

Installation should be carried out as low as possible to ensure automatic bleeding of the heater and circulation pump. This is particularly important as the circulation pump is not self-priming.



The openings of the heat exchanger may not face downward in any installation position.

Fig. 1 shows the permissible installation position of the heater.

For the position of the heat exchanger opening of the heater, see Fig. 2.
For dimensions of heater, see chapter 14, "Technical Data".

Legend Fig. 2:

- 21) Heat exchanger inlet
- 22) Heat exchanger outlet
- 23) Combustion air inlet
- 24) Fuel inlet
- 25) Exhaust outlet
- L) Length
- B) Width
- H) Height



The heater may not be installed:

- in the direct area of radiation of exhaust systems
- below the wading line of the vehicle.
- above the coolant expansion tank.



4 Type label

The label referred to in Annex 7, paragraph 4, or a duplicate, must be positioned so that it can be easily read when the heater is installed in the vehicle.

(Requirement from ECE-R 122, Point 5.3.2.4.).

The type label must be located in an area protected against damage. Inapplicable years must be erased from the type label and the current year must be retained.

Example see also Fig. 16.

5 Standard bracket

The heater must be fastened on the bracket with at least 3x heaters specific M5 bolts with 8 Nm.

The heater fastening screws are approved for bracket metal thickness of 1.5 to 3.0 mm.

The standard bracket must be secured to the car body or an intermediate bracket with at least four M6 screws.

The bracket must not be secured to the car body with self-tapping screws. If necessary, the bracket must be properly machined in accordance with the rules of technology.

See also Fig. 3: Example of a Thermo Top Evo bracket.

Legend:

- 10) Water heater
- 26) Bracket for heater
- 27) Body

6 Example of Installation in a Passenger Car

Fig. 6 shows an installation example of the heater in the vehicle.

Legend:

- 1) Radiator
- 2) Coolant thermostat
- 3) Coolant pump
- 4) Combustion engine
- 5) Exhaust silencer
- 6) Intake silencer, combustion-air intake pipe
- 7) Circulation pump
- 8) Battery
- 9) Fuse holder
- 10) Water heater
- 11) Control unit (in heater)
- 12) Mechanical shut-off valve
- 13) Fan of vehicle heater
- 14) Heat exchanger for vehicle heater
- 15) Switch for fan of vehicle heater
- 16) Fuse block in vehicle
- 17) Relay (for vehicle fan)
- 18) Heater control
- 19) Fuel metering pump
- 20) Fuel removal



7 Integration in Coolant System

7.1. Connection

The heater is connected to the vehicle coolant system as shown in Fig. 4, 6 and 7. The coolant quantity present must at least be equivalent to the volume specified in chapter 14, "Technical Data".

It is preferable to integrate the heater in the coolant system at the vehicle heat exchanger inlet.

Legend Fig. 4:

- 1) Radiator
- 4) Combustion engine
- 7) Circulation pump
- 10) Water heater
- 14) Heat exchanger for vehicle heater
- 28) Expansion tank
- 29) Thermostat



Any coolant running off should be collected using an appropriate container.

The coolant hoses supplied by Webasto must always be used. If other hoses are used, they must at least comply with the standard DIN 73411, material class B. The hoses must be routed without kinking and preferably uphill from the heater to ensure perfect bleeding.

Only hoses with an inside diameter of 18 mm may be chosen.

Hose connections must be secured against slipping off with clips.

7.2. Installing coolant connection pieces



Never mount the retaining plate and the water connection pieces when the heater has been installed.

The contact surfaces of the O-rings in the heat exchanger must be clean and must not be damaged.

The O-rings must be wetted with water before being mounted in the heat exchanger.

Lay the O-rings in the openings of the heat exchanger. Mount the water connection pieces in the retaining plate. Move the connection pieces into the required installation position.

Fasten the retaining plate with the coolant connection pieces on the heat exchanger. DG 5X15 mm self-tapping screw, torque 7 Nm.

To ensure the self-bleeding of the heater, the water-outlet connection piece must be positioned pointing 0° to 90° upward if possible.



See Fig. 8: Installing water connection pieces.



Ensure proper positioning of the sensor cable!



See Fig. 5: Position of sensor cable.

Legend Fig. 5:

- 21) Heat exchanger inlet
- 22) Heat exchanger outlet
- 30) Sensor cable



7.3. Installing coolant hoses

Ensure the correct direction of flow of the coolant when integrating the coolant hoses in the coolant circuit. To simplify installation, the coolant hoses, the water inlet and outlet on the heater and the circulation pump are marked with white arrow markings.

The clamps on the heat exchanger fittings must be mounted between the bead and the hose shoulder.

Care must be taken to bleed the cooling system before the heater is taken into service for the first time or after refilling with fresh coolant. Heater and lines should be installed in such a way as to ensure static bleeding.

Malfunctions due to overheating may occur during operation if the heater and lines have not been bled correctly.



Only spring band clamps approved by Webasto may be used for the installation of the coolant hoses.

7.4. Installing circulation pump

The circulation pump must be installed in the coolant circuit on the pressure side on the heater heat-exchanger inlet (see Fig. 4).

Ensure the correct direction of flow of the circulation pump to the vehicle coolant circuit.

The installation position of the circulation pump must be chosen so that the circulation pump is self-bleeding. It must be possible for the air volume trapped in the circulation pump to automatically escape upward via the connection piece. Incorrect installation can result in malfunctions of the circulation pump.

See Fig. 7: U4847 Econ circulation pump.

Also see chapter 11.2, "Connecting circulation pump"

7.5. Checking

After the heater and all coolant-carrying components have been installed, the entire coolant system must be checked for leaks with the system pressure specified by the vehicle manufacturer.



8 Fuel integration

The fuel filler must not be situated in the passenger compartment and must be provided with an effective cap to prevent fuel spillage.

(Requirement from ECE-R 122, Point 5.3.3.1.).

In the case of liquid fuel heaters, where a supply separate from that of the vehicle is provided, the type of fuel and its filler point must be clearly labelled.

(Requirement from ECE-R 122, Point 5.3.3.2.).

The fuel integration is carried out either in the supply or return line, or with a special fuel standpipe.

8.1. Integration in engine supply or return line

On vehicles with their own fuel feed pump in the fuel tank, the fuel must not be removed from the fuel supply line!

- If the vehicle has a check valve to the fuel tank, fuel may not be removed from the return line.
- It must be ensured that no zero balance results in the vehicle system due to the fuel removal.
- If fuel is removed from the swirl pot, it must be ensured that this pot is not completely drained.

Proper installation is carried out as shown in Fig. 9: Example of a fuel standpipe.

Legend:

- 33) from fuel tank
- 34) to metering pump
- 35) to engine

8.2. Integration via vehicle's own fuel delivery unit

Also see chapter 6, "Example of Installation in a Passenger Car"

The fuel standpipe is installed in the fuel delivery unit of the fuel tank. See Fig. 12.

Legend for Fig. 12:

- 31) Fuel standpipe
- 32) Vehicle's own fuel delivery unit with hole

The installation surface of the fuel standpipe must be clean, flat and burr-free. When mounting the fuel standpipe in the fuel delivery unit, ensure careful routing of the standpipe. This may not impair the operation of the parts of the fuel delivery unit including the fuel gauge in any operating mode. The length of the standpipe must be chosen so that a minimum distance of 10 mm over the fuel tank bottom or 20 mm over the bottom of the fuel delivery unit is ensured.

The specified securing measures of the vehicle manufacturer and the corresponding torques must be complied with.



Under no circumstances whatsoever may the fuel standpipe be installed in the fuel tank body, but instead only in the vehicle's own fuel delivery unit.

8.3. Fuel line

The fuel line is divided into the intake and the delivery line. As a result, the intake line is a connection between the fuel tank and the metering pump, while the delivery line produces the connection between the metering pump and the heater.



8.3.1. Line installation

When installing the fuel line, it must be kept as short as possible.

Intake line length [m]	max. 3.0 m
Intake height [m] (Height difference between fuel tank and metering pump)	max. 1.0 m
Delivery line length [m]	max. 9.0 m

The line must be installed protected against damage (e.g. stone impact) in all areas.

The fuel line must always be routed in cool areas to prevent the formation of bubbles due to warming. High fuel temperatures can cause heater malfunctions. As a result, the line may not be routed either past strong heat sources (e.g. exhaust gas) or near stored heat zones.

In addition, the steepest possible routing of the fuel line must be ensured from the fuel tank to the heater.

Fuel lines must be fastened in accordance with the latest technology so that, for example, line sag is avoided.

Rub protection must be installed at sharp-edged transitions.



Do not route fuel lines through the vehicle interior.

8.3.2. Line design

Only lines approved by Webasto may be used as fuel lines.

8.3.3. Connecting two lines with a hose

The correct connection of fuel lines with a hose is shown in Fig. 10.

Legend for Fig. 10:

- 41) Hose clamp
- 42) Air bubble

Check for leaks!

Only Webasto-approved fastening and connecting parts may be used.

8.3.4. Metering pump

The metering pump is a combined delivery, metering and shut-off system and is subject to specific installation criteria (see Fig.11).

The Thermo Top Evo heater may only be operated with the DP 42 metering pump.

8.3.5. Installation location

The metering pump may not be installed in the radiation area of hot vehicle parts. A heat shield must be used if necessary. The pump should preferably be installed near the tank.

The permissible ambient temperature is dependent on the fuel used, see chapter 14, "Technical Data".

8.3.6. Installation and attachment

The metering pump must be secured with a vibration-damping mounting. The installation position is restricted as shown in Fig. 11 (maximum inclination of metering pump, axial installation position of metering pump) to ensure good self-bleeding.

The arrow indicates the direction of flow of the fuel.



8.4. Label

A notice, indicating that the heater must be shut down before refuelling, must be affixed to the fuelling point.

(Requirement from ECE-R 122, Point 5.3.3.3.).

The sticker "Switch off heater when refuelling" must be applied near the filler neck.

Use the stickers provided (see Fig. 17 for an example).

8.5. Cold-resistant fuels

If you change to low-temperature fuel, the heater must be operated for approx. 15 minutes so that fuel line and metering pump are also filled with the new fuel.

We know of no negative influences due to additives.



9 Combustion air supply

The air for the combustion chamber of the heater must not be drawn from the passenger compartment of the vehicle.

(Requirement from ECE-R 122, point 5.3.5.1.).

The air inlet must be so positioned or guarded that blocking by rubbish or luggage is unlikely.

(Requirement from ECE-R 122, point 5.3.5.2.).

See Fig. 13.

9.1. Combustion air pipe

The combustion air intake line can only be used in combination with an intake silencer.

9.2. Intake silencer

The fuel intake opening must be arranged in such a way that it cannot become clogged with dirt.

The take-off point for the combustion air must be situated at a location above the wading depth of the vehicle that is cool and protected against spray; the installation space must not cause overpressure or underpressure (e.g. owing to the airstream).

A ventilation opening measuring at least 3 cm² is required if the intake opening is installed in an enclosed installation space.

Legend for Fig. 13:

- 36) Combustion air intake line
- 37) Combustion-air intake silencer
- 38) Mounting clip

9.3. Notes on installation

Screw a combustion-air intake pipe with a maximum length of 400 mm onto the combustion-air intake connection piece of the heater.

Screw the combustion-air intake silencer as far as possible into the combustion-air intake pipe.



Leaks can result in a higher noise level. Ensure an adequate distance from the exhaust system to prevent the intake of exhaust gas!

Depending on the installation, the combustion air intake silencer can be located in a suitable location and secured with the included mounting clip or other installation materials which utilise the latest technology.



10 Exhaust System

10.1. Exhaust pipe

The exhaust pipe (inside diameter 22 mm) can be routed with several bends (270° altogether, minimum bending radius 50 mm).

The total line length must be between 500 and 1,000 mm.

10.2. Exhaust silencer

It is not permissible to operate the Thermo Top Evo heater without exhaust silencer.

The exhaust silencer must be installed near the heater and must not be installed near the intake opening for the combustion air.

The exhaust silencer must be installed at least 200 mm from the heater.



Drill a 2 mm dia. condensed-water drain hole at the lowest point of the exhaust silencer.

Fig. 15 shows the exhaust silencer.

10.3. Recommendations for installation

The exhaust silencer and the exhaust pipe may not be fastened to temperature-sensitive vehicle parts (e.g. brake line, electr. lines, vehicle control units, headlights, engine undertray, plastic parts, etc.) and there must be a sufficient distance of at least 20 mm from them.

Only the exhaust pipe approved by Webasto may be used. These must be sufficiently fixed in place to ensure the minimum distances even during driving. The approved spacer brackets (see Fig. 14, Pos. 43) must be used for this purpose. The spacer must be mounted on the exhaust pipe before the exhaust pipe is installed. It is recommended that the exhaust application be installed splash-water protected.

To fasten the exhaust line (exhaust outlet), the exhaust-pipe end mounting device (EFIX, Fig. 14, Pos. 40) must be used in the engine undertray (Fig. 14, Pos. 39). See the installation instructions of the EFIX exhaust-pipe end mounting device.



Use approved spacer (see Fig. 14, Pos. 43) and EFIX exhaust-pipe end mounting device.



The spacer **must not be used as an exhaust-pipe end mounting device** in the engine undertray.



Collections of condensed water in the exhaust pipe must be drained off directly. If necessary, a condensed-water drain hole may be drilled at the lowest point.

Condensed-water drain holes may not blow onto temperature-sensitive vehicle parts.

The exhaust outlet must be located so as to prevent emissions from entering the vehicle through ventilators, heated air inlets or opening windows. (Requirement from ECE-R 122, Point 5.3.4.1.)

The exhaust outlet must be unobstructed. It must not be directed at vehicle parts. The exhaust outlet may not be located within the range of throw of the wheels.

Watch the maximum steering angle of the front wheels. It must be ensured that the exhaust outlet is not clogged and cannot be damaged under any operating conditions.

The opening of the exhaust pipe must not point in the direction of travel.



Exhaust gas

Point the direction of outflow vertically downward or a maximum of 20° opposite the direction of travel.

Fig. 14: Exhaust outlet

Legend:

- 39) Engine undertray
- 40) Exhaust-pipe end mounting device
- 43) Spacer





11 Electrical Connections

Electrical components, such as relays, fuses, switches, etc., must be installed so that they are protected from the penetration of water (splash water, high-pressure cleaners, etc.).

11.1. Connecting control unit/heater

The electrical connection of the heater is carried out as shown in Fig. 18

The power supply must not be connected until directly before commissioning. Therefore, we recommend that you connect the heater power supply as the last work step prior to commissioning.

11.2. Connecting circulation pump

The electrical connector must be routed so that the cable cannot be kinked directly after the connector under any circumstances. The electrical connector must be installed tension and pressure-free in all directions.

11.3. Installation and connection of the timer

A clearly visible tell-tale in the operator's field of view shall inform when the combustion heater is switched on or off.
(Requirement from ECE-R 122, Annex 7, point 7.1).

The timer is connected as shown in the circuit diagram in Fig.18.



Do not press on the display during installation. This can cause damage to the LCD display.

11.4. Installation of other heater controls

The installation of other heater controls must be carried out in accordance with the specific installation instructions.

The Telestart is installed in accordance with its installation instructions. The Telestart transmitter is coded to the receiver as described in the Telestart operating instructions.

The Thermo Call is installed in accordance with its installation instructions. The Thermo Call is set up as described in the Thermo Call operating instructions.

The MultiControl is installed in accordance with its installation instructions. The MultiControl is set up as described in the MultiControl / SmartControl operating instructions.

11.5. Vehicle blower

The vehicle fan is controlled by the fan relay, see the wiring diagram in Fig. 18.



The connection in the heater control unit is designed for a current consumption of $I_{\max} = 0.5 \text{ A}$.



12 Wiring diagrams

Legend for wiring diagrams see Fig. 18:

System wiring diagram for Thermo Top Evo, 12 V.



The line cross-sections specified in the system wiring diagram apply for line lengths < 4.5 m.

Table 1 Cable colours

bl	blue
br	brown
ge	yellow
gn	green
gr	grey
or	orange
rt	red
sw	black
vi	violet
ws	white



Table 2: Legend for wiring diagrams

Item	Description	Remarks
A1	Heater	Thermo Top Evo
A2	Control unit	
A4	Telestart T91	-
A5	Telestart T100 HTM	-
A6	Fuse holder	Heating / air-conditioning control unit
A7	W-bus temperature sensor	
A8	PWM Gateway	Fan controller
A9	Relay socket with fuses	
A10	Button TC4	
A11	MultiControl	
A12	ThermoCall TC4	
F1	Fuse	20 A
F2	Fuse	30 A
F3	Fuse	1 A
F4	Fuse	25 A
B1	Temperature sensor	Coolant temperature sensor
B2	Temperature sensor	Overheating
M1	Motor	Combustion air fan
M2	Motor	Circulation pump
M3	Vehicle blower	
S1	Switch for vehicle blower	
S2	Switch for vehicle blower	
E	Heating element	
Y1	Metering pump	DP42
K1	Relay	Fan relay
X1	6-pin connector	Vehicle signal
X2	2-pin connector	Power supply

Item	Description	Remarks
X3	4-pin connector	Temperature sensors
X4	2-pin connector	Circulation pump
X5	2-pin connector	Heating element
X6	2-pin connector	not in use
X7	2-pin connector	Metering pump
X8	2-pin connector	Diagnosis plug
X9	2-pin connector	Diagnosis bridge
X10	4-pin connector	Heater controls
X11	4-pin connector	Wiring harness
X12	4-pin connector	Temperature sensor W bus wiring harness
X13	4-pin connector	Temperature sensor W bus
X14	6-pin connector	Telestart T91 / T100 HTM
X16	2-pin connector	Circulation pump
X17	4-pin connector	MultiControl
X18	4-pin connector	Wiring harness
X19	4-pin connector	Wiring harness
X20	4-pin connector	Wiring harness
X22	4-pin connector	ThermoCall
X24	4-pin connector	Relay socket with fuses
X25	4-pin connector	Air-conditioning control unit
①	Present in vehicle	Socket PWM Gateway
②	Fan controller	
③	Air-conditioning control unit	
④	Aerial	
⑤	Plug connection	View of Line Side
⑥	Wiring harness	

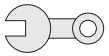

13 Initial start-up



The safety precautions in the operating instructions must be observed!

The operating instructions must be read through without fail before starting the heater.

After the heater has been installed, the coolant circuit and the fuel supply system must be carefully bled, taking into account the directions of the vehicle manufacturer.

In addition, the circulation pump must be controlled via the component test function of the Webasto Thermo Test PC Diagnosis to bleed the coolant system.

Before the heater is commissioned, the coolant temperature should be $< 30^{\circ}\text{C}$, as the heater does not go into combustion operation at high engine temperatures.

Commissioning must be carried out with the Webasto Thermo Test PC Diagnosis.

Prime the heater with fuel using the Webasto Thermo Test:

Press the "Fuel prime" button in the component test selection menu and fill the lines until fuel is present at the heater.

Example:

43 sec. filling time with 300 cm line length, 7 Hz metering pump frequency.

The CO_2 setting must be checked while operating the heater for the first time (for value range, see chapter 14, "Technical Data").

Webasto recommends a setting of 10 vol. %.

All coolant and fuel connections must be checked for leaks and secure attachment during the trial run of the heater. All faults entered in the heater memories must be deleted before turning the vehicle over to the customer.



14 Technical Data

14.1. Technical Data for Thermo Top Evo

Except where limit values are specified, the technical data below refer to the usual heater tolerances of $\pm 10\%$ at an ambient temperature of $+20\text{ °C}$ and at the rated voltage.

14.2. Technical data of circulation pump

Circulation pump	4847 Econ
Delivery rate against 0.1 bar	approx. 900 l/h
Rated voltage	12 V
Operating voltage range	10,5 to 17 V
Rated power consumption	14 W
Dimensions, circulation pump	Max. length: 109 mm Diameter: 48.5 mm
Weight	approx. 0.3 kg

Heater	Operation	Thermo Top Evo B		Thermo Top Evo - D	
		5 kW	4 kW	5 kW	4 kW
ECE approval mark		E1 122R 00 0258 (heater) E1 10R 04 5627 (EMC)			
Model		Water heater with evaporator-type burner			
Heat output	max. heating capacity min. heating capacity	5.0 kW 2.8 kW	4.0 kW 2.8 kW	5.0 kW 2.5 kW	4.0 kW 2.5 kW
Fuel		Petrol EN 228 DIN 51625		Diesel EN 590	
Fuel consumption +/- 10%	max. heating capacity min. heating capacity	0.705 l/h 0.395 l/h	0.560 l/h 0.395 l/h	0.620 l/h 0.310 l/h	0.495 l/h 0.310 l/h
Rated voltage		12 V			
Operating voltage range		10,5 to 17 V			
Nominal power consumption +/- 10% (without circulation pump and vehicle fan)	max. heating capacity min. heating capacity	33 W 15 W	21 W 15 W	33 W 12 W	21 W 12 W
Perm. ambient temp.: Heater: - Operation - Storage Metering pump: - Operation - Storage	Summer fuel Winter fuel	-40 to +60 °C -40 to +120 °C -40 to +20 °C -40 to +10 °C		-40 to +80 °C -40 to +120 °C -40 to +30 °C	
Perm. operating pressure		2.5 bar			
Capacity of the heat exchanger		0.075 l			
Minimum quantity of coolant circuit		2.0 + 0,5 l			
Minimum flow rate for the heater		200 l/h			
CO ₂ in exhaust gas (perm. function range)		8 to 12.0 vol. %			
Dimensions of heater without attached parts Also see Fig. 2. (Tolerance ± 3 mm)		L = Length: 218 mm B = Width: 91 mm H = Height: 147 mm without coolant connection piece			
Weight		2.1 kg			



Page for notes

BUTLER TECHNIK

www.butlertechnik.com

Bei mehrsprachiger Ausführung ist Deutsch verbindlich.

Die Telefonnummer des jeweiligen Landes entnehmen Sie bitte dem Webasto Servicestellenfaltblatt oder der Webseite Ihrer jeweiligen Webasto Landesvertretung.

In multilingual versions the German language is binding.

The telephone number of each country can be found in the Webasto service center leaflet or the website of the respective Webasto representative of your country.

如果有多国语言版本，以德语版为准。

每个国家的联系电话都能够在伟博思通的服务中心或者你所在国家的伟博思通官方网站上找到。

Webasto Thermo & Comfort SE

Postfach 1410

82199 Gilching

Germany

Visitors Address:

Friedrichshafener Str. 9

82205 Gilching

Germany

Technical Extranet: <http://dealers.webasto.com>

www.webasto.com

www.butlertechnik.com