

# Marine Installation Instructions

## ThermoTop Evo

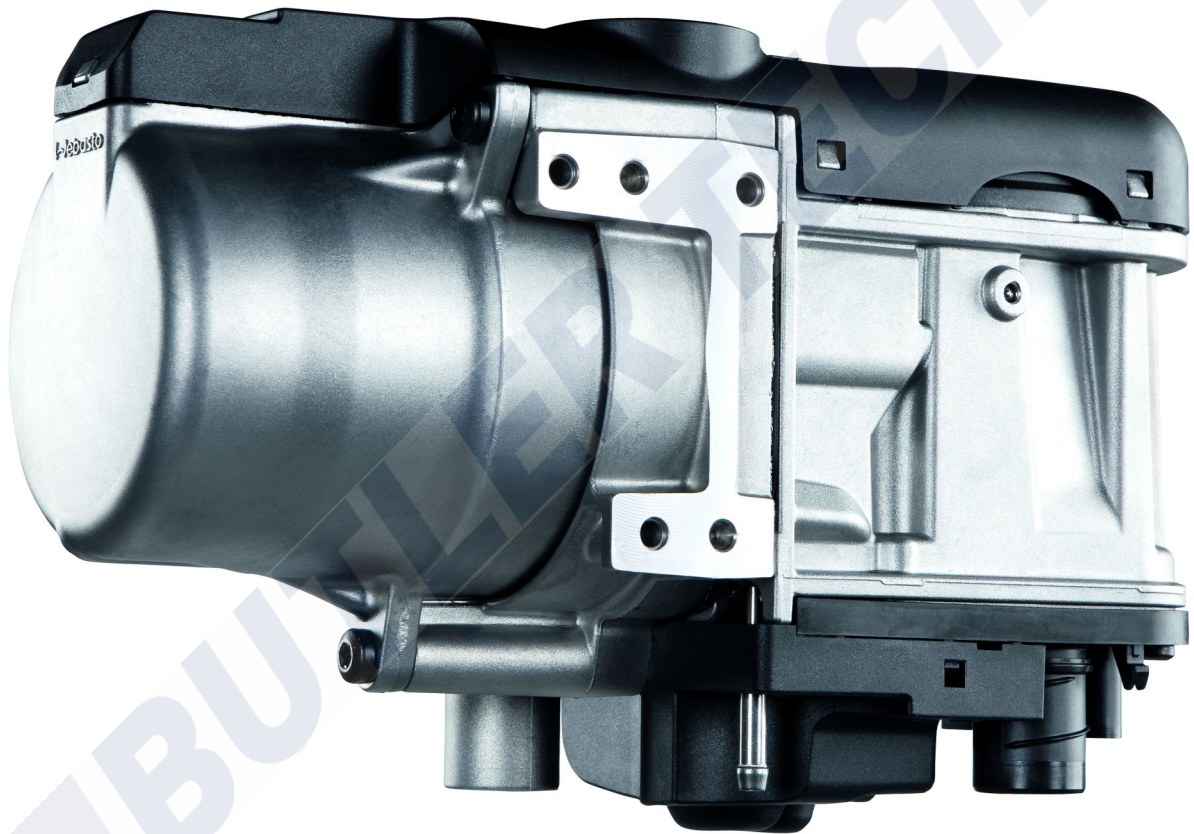

## Table of Contents

1. Cover page
2. Table of contents
3. Safety warnings
- 4 - 6. Warranty Terms
7. Technical information.
8. Position and mounting of the heater.
- 9 - 10. Exhaust System
11. Combustion air.
- 12 - 14. Fuel System
- 15 - 17. Plumbing system
- 18 - 21. Electrical system
22. Commissioning



Improper installation or repair of Webasto heating systems can cause fire or the leakage of deadly carbon monoxide leading to serious injury or death.

To install and repair Webasto heating systems you need to have completed a Webasto training course and have the appropriate documentation, special tools and equipment.

**NEVER** try to install or repair Webasto heating systems if you have not completed a Webasto Training course, you do not have the necessary skills and you do not have the technical documentation, tools and equipment available to ensure that you can complete installation and repair work properly.

**ALWAYS** carefully follow Webasto installation and repair instructions and heed all WARNINGS.

Webasto rejects any liability for problems and damage caused by the system being installed by untrained personal.

# Warranty



## Warranty Terms

Webasto Thermo & Comfort UK Ltd warrants against defects in manufacturing and material, products, replacement parts and accessories supplied by the company.

The warranty duration is conditional upon the product service recommendations being adhered to. The warranty covers only those components purchased through Webasto Thermo & Comfort UK Ltd or via its Authorised Dealer Network.

Upon expiry of the product warranty, all warranties on components or services supplied during the product's warranty period will also cease.

Unless specifically branded and containing instructions for the end customer installation, all Webasto products are intended for installation only by Webasto trained personnel.

In instances where Webasto Thermo & Comfort UK Ltd have carried out, or are contractually responsible for, the installation or repair of a product, warranty against defective workmanship or component damage to the vehicle or boat, caused as a direct result of defective workmanship, is limited to 3 months.

All following exclusions apply to all warranties:

The product was not sold, installed and commissioned by a Webasto Authorised Dealer or Approved Installer

The product details are not registered with Webasto Thermo & Comfort UK Ltd

An operator or customer not having given notice, at once, of any fault having developed, providing Webasto Thermo & Comfort UK Ltd or a Webasto Authorised Dealer or Approved Installer the opportunity of rectification

Failure of the equipment through abuse, unreasonable treatment or the use for which the appliance was not designed for

The stipulated servicing requirement not being adhered to or the service being conducted by a non-approved third party

Installation of replacement parts into or in conjunction with the equipment, which are not approved by Webasto Thermo & Comfort UK Ltd

Changes in the appearance of the appliance or modifications in a way which the manufacturer has not agreed or sanctioned the change

Installation faults which are in conflict with the Webasto Thermo & Comfort UK Ltd specifications or instructions in force at the time of installation

## Warranty



Glow Plugs / Pins, Burner Cartridges, Gaskets and Seals normally replaced during routine servicing, will not be covered by the warranty, either to qualify for, or within the duration, of any specific warranty period

Failure of product due to no or low battery power supply / insufficient fuel supply including the activation of any fuel cut off device or not installed or operated in accordance with Webasto official installation and operating guidelines

Travelling time and mileage incurred in order to affect repairs, (unless the installation of the product is such that it cannot practically be taken to a Webasto Authorised Dealer)

Failure of product caused by any external influence

These exclusions also preclude any claims for labour associated with the diagnosis, or repair, of any defects falling wholly within the scope of the exclusions.

Warranty cover commences upon the date of purchase of the product, or of the equipment into which the product is installed from new. All warranty claims must be presented with proof of purchase of the product prior to the commencement of any repair.

This warranty is in substitution for any implied warranties, including implied warranties as to satisfactory quality, which are hereby excluded. Webasto limits liabilities to either repair or replacement of products/parts as is deemed necessary.

The following third party costs are not covered within these warranty terms:

- Costs incurred for replacement vehicles
- The loss of any goods within the vehicle
- Any loss of earnings
- Costs for parts and labour due to mis-diagnosis and repair

Webasto Thermo & Comfort UK Ltd shall not be liable for any consequential loss or damage, however arising.

Defects covered by this warranty should be notified to the original provider of the product or to a Webasto Authorised Dealer. Subject to satisfactory validation of the warranty period, as detailed above, Webasto Thermo & Comfort UK Ltd will, at its discretion, repair or replace the product at no charge.

**If the purchase was a consumer transaction, your Statutory Rights are not affected.**

A Product Warranty Registration Document is included with all products supplied by Webasto Thermo & Comfort UK Ltd. This document must be completed by the Webasto Authorised Dealer or Approved Installer and a copy returned to Webasto Thermo & Comfort UK Ltd for registration purposes. The document also details the terms of warranty offered by Webasto and has a section for completion by the Webasto Authorised Dealer or Approved Installer, to record the warranty commencement date. In the event of a claim, the Webasto Authorised Dealer or Approved Installer should refer to this document to ascertain the warranty applicable to the product and submit a copy of the installation record with the warranty claim form relating to the repair.

## Warranty



### Period of Warranty Cover

The warranty period applicable to combustion heater products supplied by Webasto Thermo & Comfort UK Ltd is 36 months from the registration date of the vehicle etc. as per the following conditions:

The product is supplied via Webasto Thermo & Comfort UK Ltd direct or through one of the official approved outlets

It is installed by a Webasto Authorised Dealer or Approved Installer

Installation document is fully completed by the Webasto Authorised Dealer or Approved Installer and returned to Webasto Thermo & Comfort UK Ltd to enable the product to be registered on our Product Registration System

If the product is a sale only transaction and/or a self-install it must be commissioned by a Webasto Authorised Dealer or Approved Installers

That the vehicle is operated within the UK

**FAILURE TO COMPLY WITH THE ABOVE CONDITIONS WILL LIMIT THE WARRANTY PERIOD TO 24 MONTHS RETURN TO THE ORIGINAL SUPPLIER.**

When replacement parts are fitted to any product in order to effect a warranty repair, the warranty period applicable to that product will remain as originally specified. The warranty applicable to any components used to affect a warranty repair will also cease at the expiry of the product warranty

Replacement parts sold as a customer transaction are warranted for 12 months, provided that a proof of purchase can support any subsequent claim.

## Technical Information



### THE HEATER

The ThermoTop Evo is a diesel powered 5 kw heater with a variable heat output between 5kw and 2.5kw.

Heated water is supplied to the vessel's heating system, consisting of household style radiators or blower boxes and an option of domestic hot water is also possible with the use of a calorifier.

The heater burns diesel fuel supplied from the vessel's main fuel tank, the correct amount of fuel is measured and drawn by the dosing pump prior to delivery to the combustion chamber. On arrival in the combustion chamber, the fuel is vaporised off a unique Ferro-Tech burner initially being ignited by a glowpin. Following starting the heater, combustion is sustained by the continuous vaporisation of the metered fuel delivery.

Combustion takes place within a sealed heat exchanger, and exhaust gasses are ducted to the vessel's side or transom via a sealed stainless steel exhaust /silencer assembly.

The circulation pump circulates cool water into the heater heat exchanger, where it is heated and re-introduced hot into the heating system to heat the radiators etc.

Operation of the heater is either via W-Bus using the Mutli-Control or via an analogue switch.

If blower boxes are used, optional controls and thermostats are available to regulate the individual cabin temperature's.

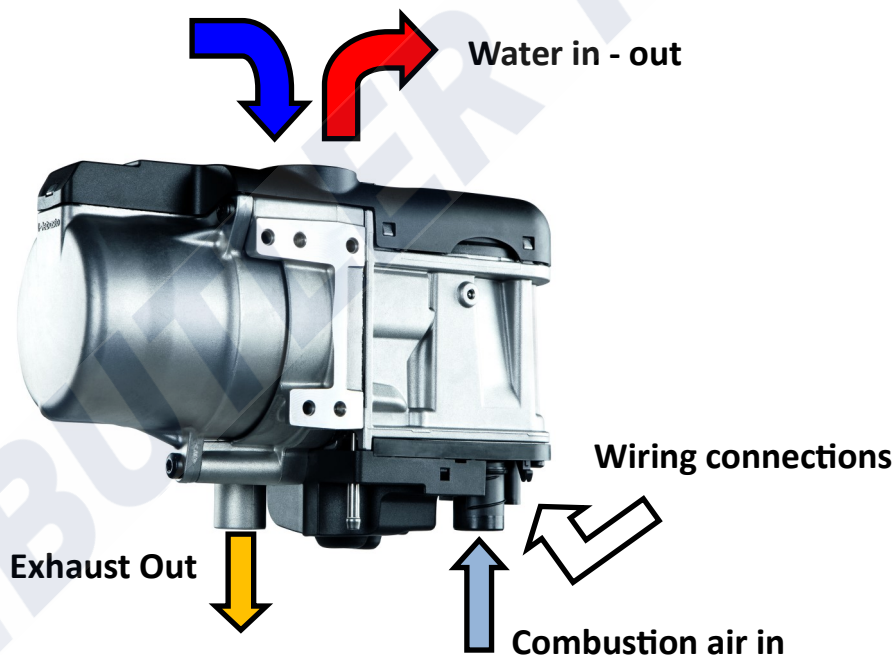



## Positioning and Mounting of the Heater



The heater requires a dry, protected area which will not be affected by seawater, excessive vibration or fumes.

The location of the heater must be well clear of gas storage and piping.

When choosing the location, bear in mind ease of access for maintenance, servicing and location of the heater in relation to other mechanical items on the vessel.

It is important to consider the required installation requirements of the heater's ancillary components,

1. Exhaust maximum/minimum length
2. Exhaust outlet point
3. Combustion air maximum/minimum length
4. Circulation pump location and orientation
5. Fuel dosing pump location and orientation
6. Fuel pick up
7. Electrical supply and cable routing

The lazarette or engine room is the favoured position, where fuel combustion air and access to the hull are at hand.

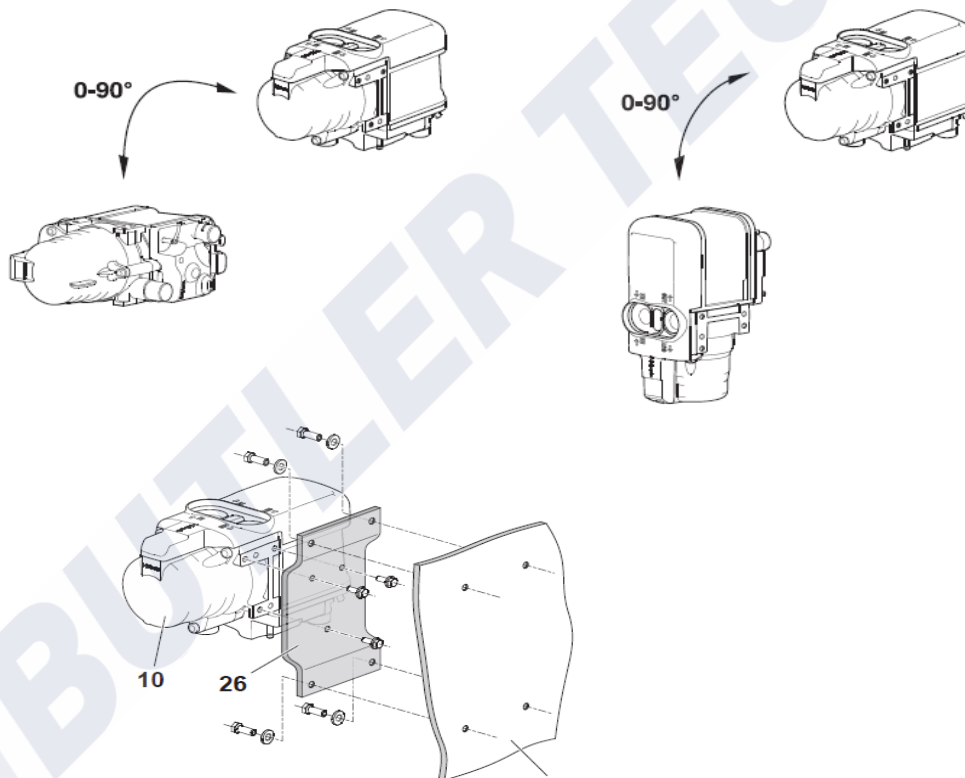

The heater should be fitted as low as possible to ensure automatic bleeding of the heater and circulation pump. This is particularly important as the circulation pump is not self-priming.



The opening of the heat exchanger may not face downward in any installation position

The heater must be fastened on the bracket with at least 3 x heater specific M5 fixing provided at 8Nm torque.

The heater and bracket must be secured to the vessel with at least 4 x M6 screws.



## Exhaust System



The exhaust system must be installed using the marine sealed exhaust pipe and silencer supplied in the kit.

It must be ensured that **NO** exhaust gases can enter the living spaces of the vessel.

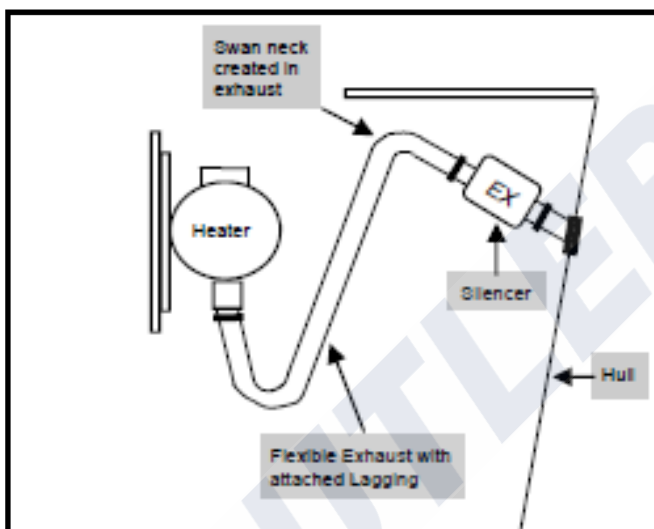
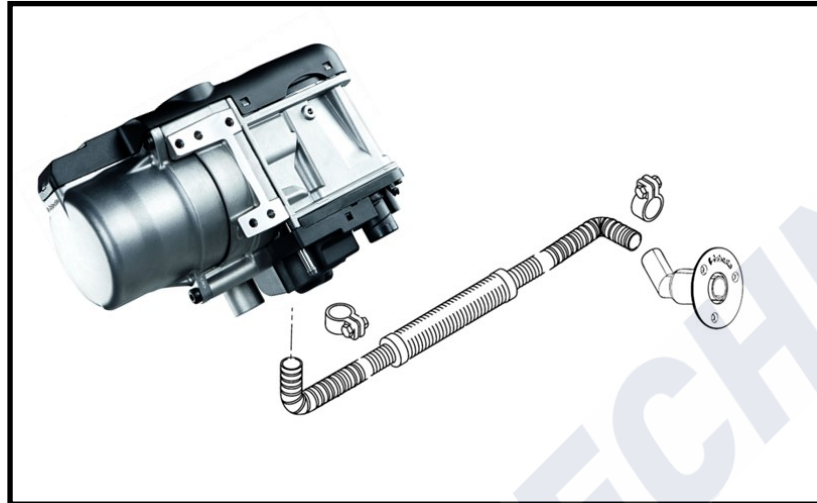

The exhaust pipe is 24mm ID, the reducer sleeve which is supplied in the kit needs to be fitted to the heater to enable the exhaust to fit onto the heater correctly.

Create a swan neck in the exhaust to prevent water ingress.

Minimum bend radius            50mm

### Total bends

Exhaust pipe                        270°

The exhaust system must not be secured or routed near temperature sensitive parts of the vessel.

Only the sealed exhaust supplied in the kit by Webasto may be used.

The exhaust must be lagged with the woven glass protective sock supplied in the kit, if additional heat protection is required this is available from your local Webasto Dealer, use the stainless steel cables ties supplied to secure the exhaust insulation in place.

## Exhaust System

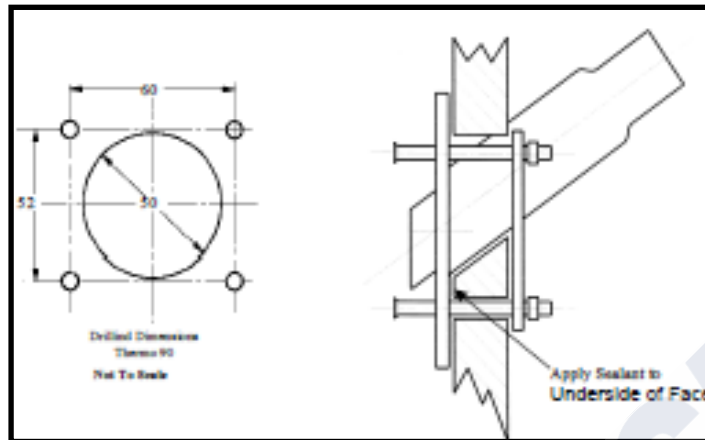

The skin fitting is normally fitted on the transom for sailing vessels. The hull side is acceptable for motor boats but bear in mind the bow wave line and beam sea risk.

---

## Combustion air

The air for combustion must not be taken from the cabin of the vessel.

The air inlet must be positioned or guarded from blockage .

The heater is supplied with a length of combustion air pipe 36 and silencer 37. This should be placed in such a position to provide dry, cool air to the heater unit. Always fit the pipe and silencer.

If mounting in the engine room, ensure that no foreign bodies can enter the intake silencer.

Do not let the pipe hang down if a potential exists for bilge water to enter the pipe if the vessel heels over in heavy seas.

Avoid mounting the intake in such a manner that engine drive belt dust could enter the heater.

The combustion air pipe supplied is the maximum length permitted and must not be extended.

### Total bends

Combustion air pipe 270°

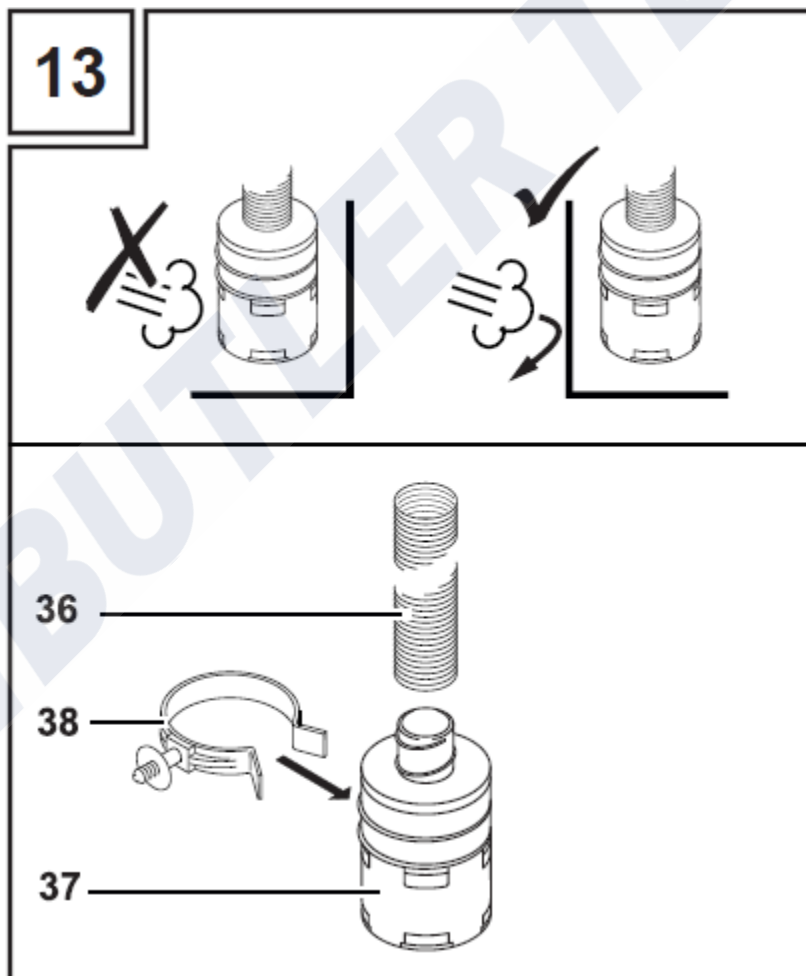

## Fuel system



The heater kit is supplied with copper fuel line.

**It is the installers responsibility to ensure the fuel system installation conforms to the correct standards , i.e RCD, MCA.**

### FUEL EXTRACTION.

Fuel must be extracted directly from the boats fuel tank via a **Webasto** approved standpipe .

1. The standpipe must be installed as shown below, the end must be approx. 25mm above the bottom of the tank or high enough that fuel for the boats engine always remains in the tank. Cut the tube diagonally and de-burr the cut edges.
2. Drill a 25mm hole in the top of the tank , **Note** : before drilling, grease the top of the tank around the intended drilling area to collect any swarf which will be present.

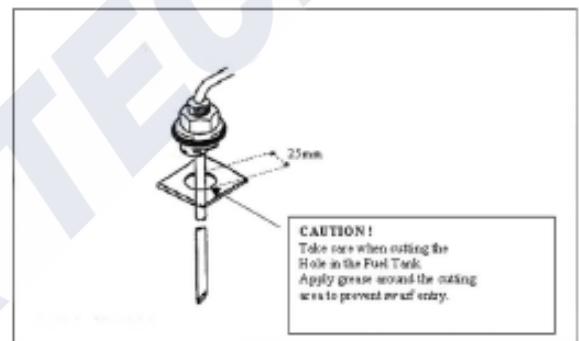
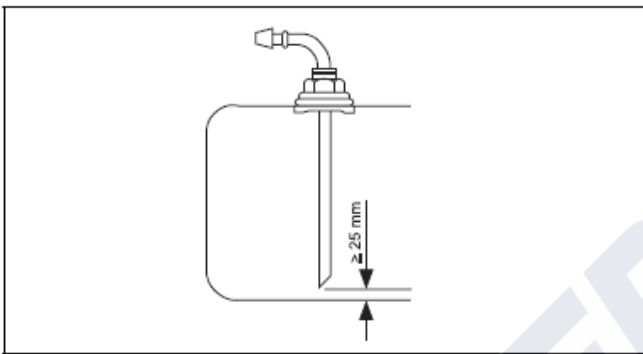

Webasto Standpipe

### FUEL PUMP

The fuel pump is controlled via the supplied wiring harness and feeds fuel into the combustion chamber of the heater unit depending on the required heating capacity.

1. Fit the pump within 1m of the fuel stand pipe.
2. Install the pump in a dry cool area. Do not install in the bilge.
3. Note the pump flow direction.
4. Use the rubber mount provided in the kit to mount the pump.

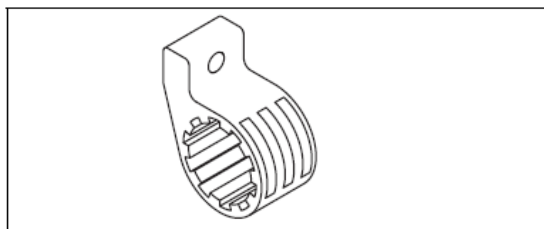

# Fuel system



## FUEL PIPING

The kit is supplied with copper fuel pipe, it is the fitters responsibility to ensure the fuel system meets the correct. **Only fuel lines approved by Webasto may be used.**

1. The fuel hose is connected to the standpipe, pump and heater using the 50mm long rubber hose pieces. It is important to ensure the pipe is correctly inserted into the rubber joiners to prevent air bubbles form forming see image below..
2. If other pipe fittings are needed due to different fuel supply arrangements i.e. in-line filters or water traps contact your local Webasto Dealer for details.
3. Follow the diagram below for connecting the fuel supply and positioning the components, noting the mounting parameters for the fuel pump and heater which are critical to ensure trouble free operation.
4. The fuel system is divided into two halves Intake side which is from the standpipe to the pump and the Delivery side which is from the pump to the heater. Ensure the parameters shown below are followed .
5. Ensure the fuel line is kept as short as possible and is protected from damage.
6. Ensure the fuel line is routed in cool areas.
7. The ball valve , Filter / Separator are optional and may not be part of your kit. Optional parts mentioned are available from your local Webasto Dealer.
8. The fuel pump mounting orientation is critical to correct performance. Mount the pump horizontally using the supplied rubber mount. Do not mount the pump near heat sources and ensure it is not exposed to mechanical damage.

<b>Intake line length [m]</b>	max. 3.0 m
<b>Intake height [m]</b> (Height difference between fuel tank and metering pump)	max. 1.0 m
<b>Delivery line length [m]</b>	max. 9.0 m

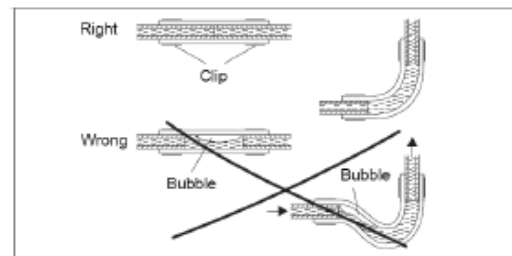

*Illustration of how to insert a copper pipe into a rubber joiner.*

3m below the heater .

9. The pump must not be mounted more than

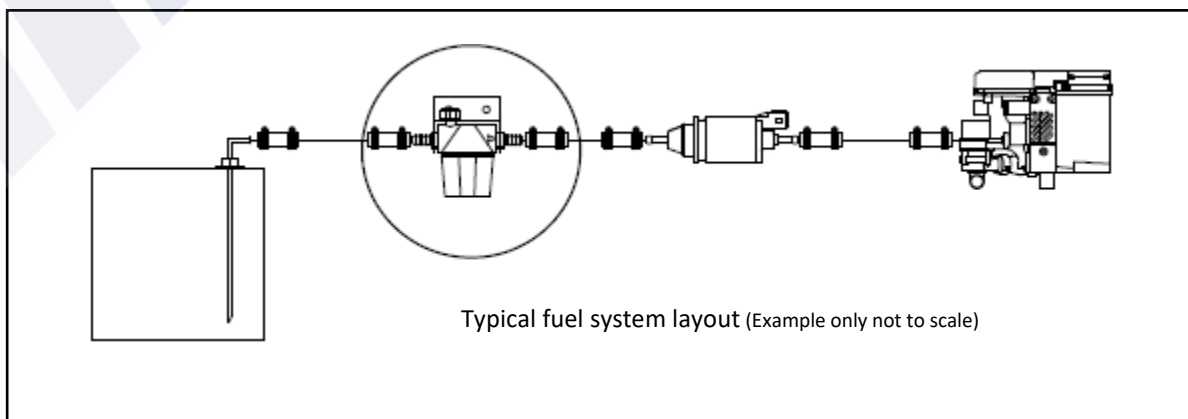

## Fuel system



### Fuel filter kit.

Some heater kits are supplied with a filter, if you do not have a filter kit and require one the part number for the approved filter is 4110766A, this is the only Webasto approved filter for use in a marine application.

The Webasto filter kit has been selected specifically to be used for this heater in a marine application.

Please refer to the installation instructions supplied with the filter kit for further details.

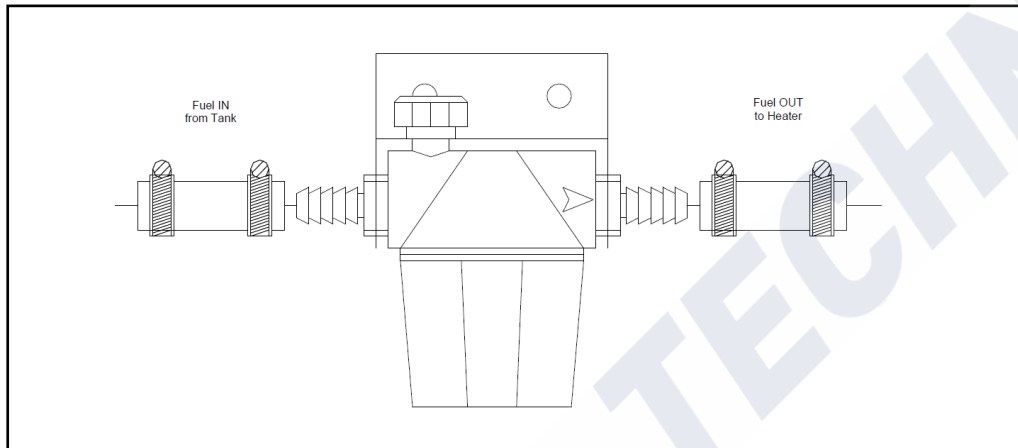

# Plumbing system

## Plumbing system overview

Figure 1 shows a gravity system with a two pipe header tank.

This system circulates water through the header tank to remove large amounts of air. The header tank also adds to the overall volume of coolant in the system which helps the heater perform efficiently. It is important to ensure the header tank used does not increase the restriction in the circuit.

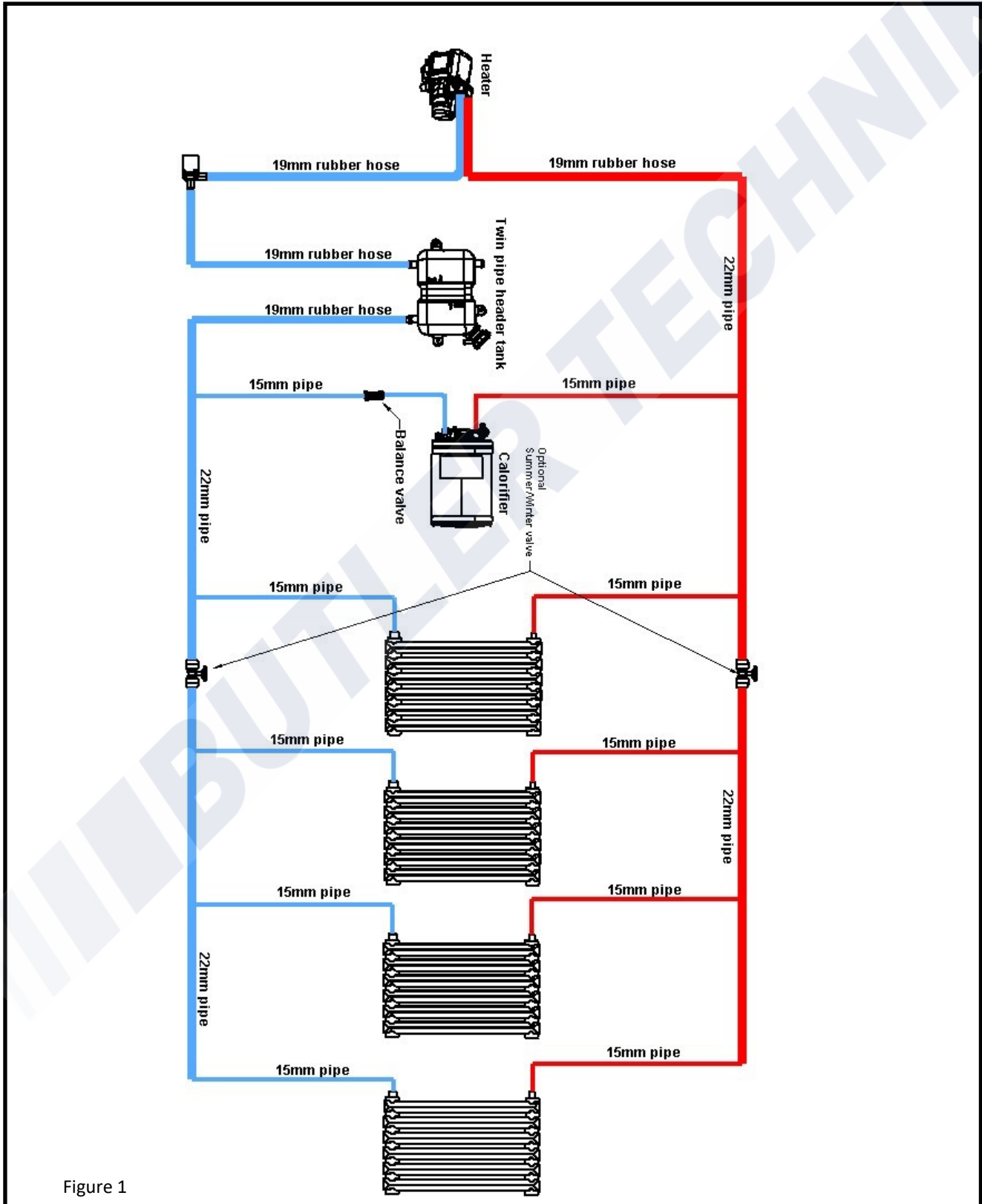

Figure 1



# Plumbing system



## Plumbing system overview

Figure 2 shows a gravity system with a two pipe header tank and bypass valves.

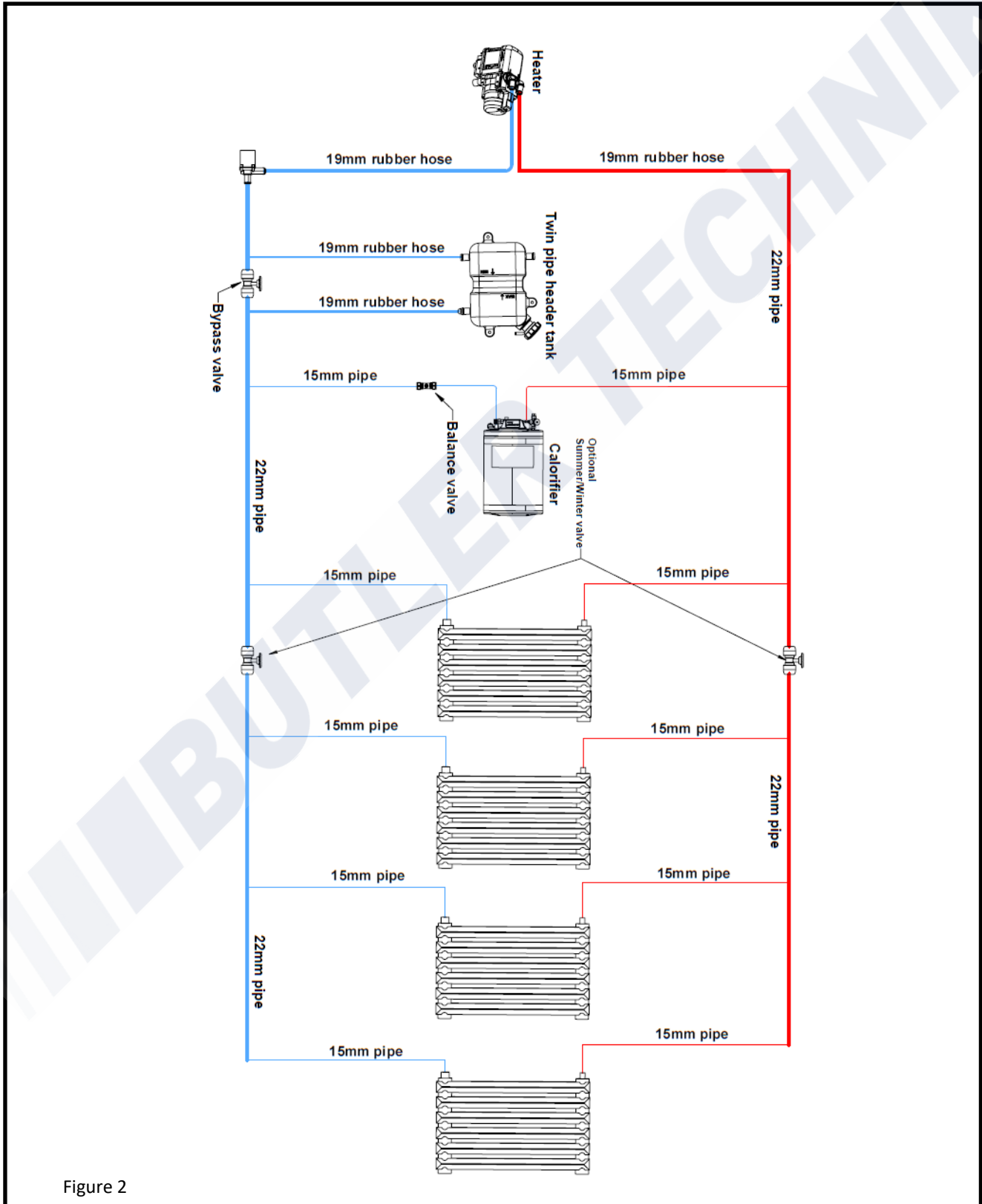

Figure 2

## Plumbing system

Figure 2,

The header tank uses two vertical pipes, one in and one out as in the above example

However, the two vertical pipes connect to the spine via 2 Tee pieces.

In between the two Tees, a ball valve is fitted.

The reason for this is to speed up the air purging as in example 2, but to also negate the formation of micro bubbles.

How it works. When the system is dry and being commissioned we need to get as much air out of the system as possible so we Close Valve A. This forces the water up into the header tank and back down to the circulation pump and is a good performance indicator of the air / water content during the commissioning process. When all the visible air bubbles have been removed Open Valve A. The micro bubbles will now eventually vent from the water and into the header tank. As opposed to example 2 the header tank in this system no longer acts as a radiator or imposes any additional flow resistance.

This is the most efficient non-pressurised header tank system.

Figure 2

# Plumbing system



## Plumbing system.

The Thermotop Evo kit includes a header tank and hoses suitable for connection to 22mm plastic push fit piping e.g Hep2o.

Figure 1 shows a simple non pressurized system layout containing the heater, radiators, calorifier and header tank.

The hot water plumbing can use typical domestic heating plumbing components. The heating systems must use a flow and return line as shown in figure 1 made up with 22mm OD plastic or Copper pipe, Hep2o, Speedfit ect. The heater is supplied with rubber hoses which are suitable for connecting to the 22mm flow and return pipes using threaded hose tails connected to push fit fittings. The radiators are connected to the 22mm flow and return pipe with 22x15x22mm unequal tees.

**Heater & circulation pump:** The heater and circulation pump are mounted separately, a short electrical harness is supplied in the kit. The heater is marked with OUT(Flow) & IN(Return) on the top plastic cover.

The coolant hoses supplied by Webasto must always be used. The hoses must be routed without kinking and preferably uphill from the heater to ensure perfect bleeding. Hoses must be secured against slipping off with suitable sized clips supplied in the kit.

The installation of the heaters hose connections must not be done when the heater has been installed. The contact surfaces of the O-rings in the heat exchanger must be clean and must not be damaged. Wet the O-rings before mounting in the heat exchanger. Lay the O-rings in the openings of the heat exchanger, mount the water connection pieces in the retaining plate, move the connection pieces into the required position. Secure the retaining plate with the coolant connection pieces on the heat exchanger using the supplied screws to 7Nm. Refer to the heater installation manual for further detail.

Ensure the correct direction of flow of the coolant when integrating the coolant hose. The water inlet and outlet on the heater and the circulation pump are marked.

Care must be taken to bleed the coolant system before the heater is started for the first time. Malfunctions due to overheating may occur during operation if the heater and lines have not been bled completely.

The circulation pump must be installed in the coolant circuit on the return side to the heater. Ensure the correct direction of flow is observed. The orientation of the coolant pump must be chosen so that it is self - bleeding. It must be possible for the air volume trapped in the pump housing to automatically escape upward via the pump outlet. Incorrect installation will result in pump and heater malfunctions.

## Header Tank:

Depending on what kit you have it may or may not be supplied with a header tank. The header tank can be installed in a vertical or horizontal orientation. The tank is designed to be installed using the two ports at the bottom this ensures auto bleeding and adds to the volume of coolant in the system. Ensure the header tank is installed at the highest point in the system.

**Calorifier & balance valve:** A calorifier can be fitted into the system if required, ensure an isolation valve is used in the return line to enable the circuit to be balanced to prevent a short circuit through the calorifier loop.

**Summer/winter valves:** These valves can be fitted to isolate the radiators in summer time however it must be ensured that one radiator remains open at all times usually the bathroom towel radiator. This ensures the heater has sufficient load to ensure reliable operation.

## Don't use thermostatic radiator valves

Only use standard lock shield valves on the radiators. TRV's will cause differential pressure problems that will effect the balance of the water flow and consequently have an effect on the heater with regards to short cycling.



## Correctly load the heater

If the heater has a maximum output of 5kw, then it is recommended to have a load 10% greater than the heater output. This will ensure that the heater will run at full load for longer.



## Balance the system.

Balance the radiators with the lockshield and remember to fit a balance valve to the calorifier coil outlet pipe.



## Glycol, (Antifreeze) Type and percentage of concentration.

As with any type of water heating system it is necessary to add some kind of corrosion inhibitor. In the case of Webasto heaters it is recommended to use IAT ethylene glycol, the antifreeze must be glycol and NOT methanol based. We recommend a glycol content of 25% for Webasto heating systems. The glycol and water must be mixed thoroughly before filling the system. If it is not pre-mixed there will be slugs of hot water and cool glycol circulating around the system.



## Additives

Do not add any additives to the water heating circuit.



## Bleeding the water system

Ensure that all air is bled from the water circuit and the header tank level is correct before starting the heater for the first time. Once the heating system has been bled the heater can be started and the remaining air bled from the system.

## Electrical system



Ensure the vessels DC electrical system is compatible with the voltage rating of the heater.

The power supply must not be connected until directly before commissioning. Therefore, we recommend that you connect the heater power supply as the last work prior to commissioning.

Each heater kit is supplied with a dedicated pre-terminated harness suitable for the heater. It is therefore **not** permitted to alter the harness without consulting Webasto.

The harness is made as one piece however there are 7 different sections which need to be terminated these are labelled accordingly.

### Installation of the main harness (Analogue switching version only)

The harness is approximately 5m long, ensure that when mounting the heater, fuel pump and control the harness is able to reach the individual components. Remember the circulation pump has its own dedicated harness in the kit and is not part of the main harness.

#### 1. Battery connections,

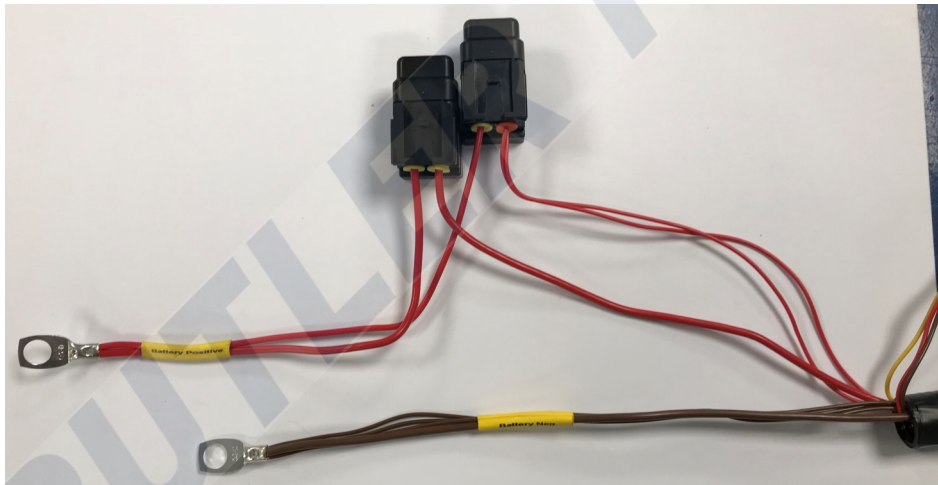

The ring terminal marked **BATTERY POSITIVE** must be connected to the vessels domestic battery bank or to the battery side of the master switch, this is to ensure the heater shuts down correctly in the event power is lost due to a breaker or isolator being turned off. Failure to allow the heater to shut down correctly will cause damage to the heat exchanger which will not be covered by your warranty. The terminal marked **BATTERY NEGATIVE** must be connected to battery negative or to the load side of the shunt if fitted.

The harness/heater is protected by 2 blade fuses, 20 amp for the main power and a 1 amp for the control circuit.

## Electrical system



### 2. Heater,

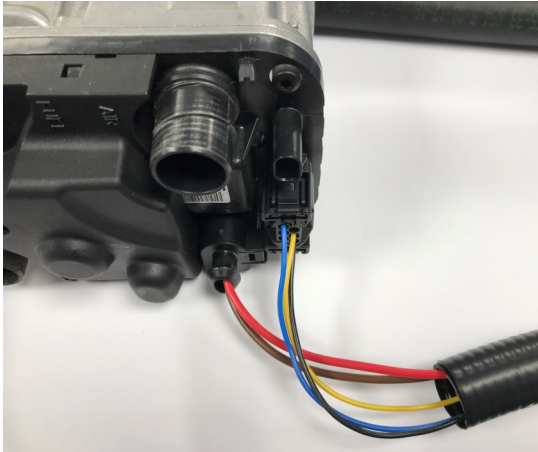

The harness has two plugs for the heater a 6 way and a 2 way, the plugs can only be connected in one way so it is not possible to connect them incorrectly.

### 3. Control.



The kit is supplied with a timer control, please refer to the supplied installation and operating instructions for the timer. The harness is supplied with the correct plug for the timer.

### 4. Fuel Pump.



The harness is supplied with the correct connector to plug directly into the fuel pump.

## Electrical system



### 5. Diagnostics,

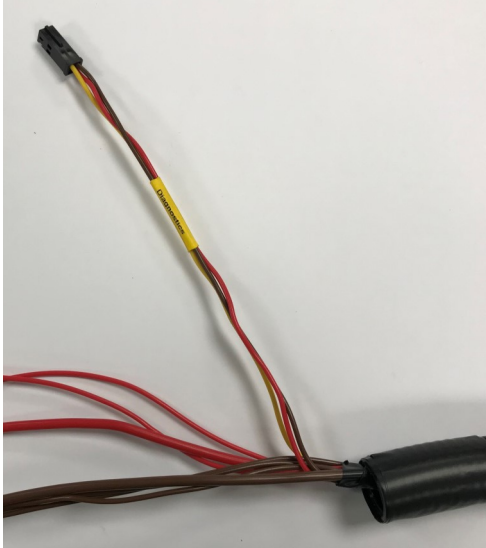

The heater has a dedicated diagnostics connector for maintenance and servicing, this tool is only available to trained and approved dealers and installers.

### 6. Circulation pump

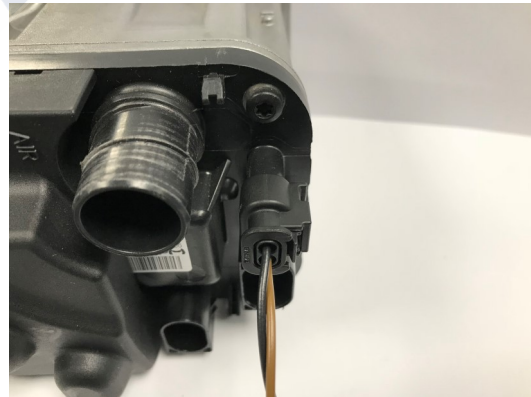

A separate harness is supplied to connect the heater to the circulation pump, it does not matter which end is plugged into the heater or circulation pump.



# Electrical system



Wiring Harness schematic

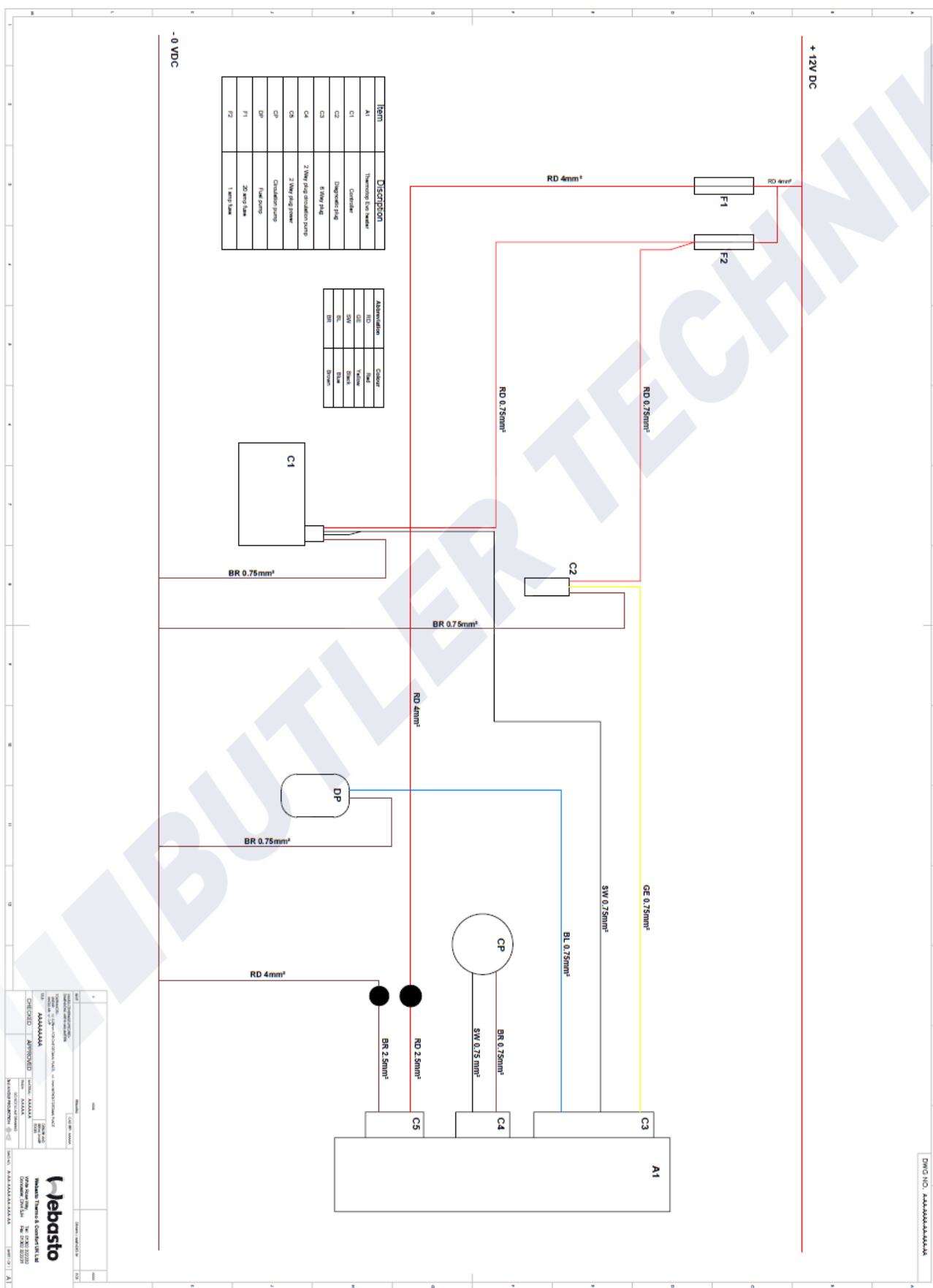

## Commissioning



### Header tank installations.

Commissioning ideally should be carried out by a trained and approved Webasto dealer using Webasto Thermo Test tool.

Upon completion of the installation, check the integrity of all plumbing and electrical connections.

Fill the heating system with 75/25 water/antifreeze mixture through the header tank.

Connect the battery cables.

Webasto recommend the use of the Thermo Test diagnostic tool to bleed the water system and fuel system before starting the heater for the first time.

There is a potential that the heater will lockout if the water and fuel system is not bled correctly.

Start the heater from the control panel, once the heater is running, air will bleed out of the water system and the header tank will required constant refilling to the max mark. It may be necessary to bleed the radiators manually. Allow the heater to run up to full load and check that all air locks have bled from the system.

The CO2 setting must be checked while operating the heater at full load for the first time, refer to heater documentation for the correct operating range, Webasto recommends a setting of 10 vol. %

Switch off the heater and allow the system to cool, check the header tank water level and top up if required with water/glycol mixture.

Check all plumbing connections for leaks and repair if required.

All faults in the heaters memory must be deleted before signing of the installation.