

Air Heaters
Chauffages à air
Riscaldatori ad aria

Workshop handbook
Manuel d'atelier
Manuale per officina

HL 18 B

(Petrol / Essence / Benzina)

HL 18 D

(Diesel / Gas-oil / Gasolio)

HL 18 D

(Reduced Heat)
(Régime partiel)
(Potenza ridotta)

(Diesel / Gas-oil / Gasolio)

HL 18 D (TRS)

(Diesel / Gas-oil / Gasolio)

Air Top 18 D

(Diesel / Gas-oil / Gasolio)

1/1993

 **Webasto**

Foreword

This repair shop manual is intended to provide all the necessary information for familiarization with all versions of the Air Heater Series HL18 Petrol and Diesel as well as AirTop 18 Petrol and Diesel. The AirTop heaters are an upgrade development of the HL heaters. The manual does not replace the Webasto training course, but is used in many cases as a useful reference guide for initial operation, maintenance, repair, or for removal and installation of the heaters.

Due to the complex technical details, different applications and continuous progress in development, the repair shop manual cannot cover the complete range of possible problems. Additional Webasto publications have to be queried as required:

Operating Instructions	HL 18 B HL 18 D HL 18 D (Part-Load) HL 18 D (TRS) Air Top 18
Installation Instructions	HL 18 B HL 18 D HL 18 D (Part-Load) HL 18 D (TRS) Air Top 18
Spare Parts List	HL 18 B HL 18 D HL 18 D (Part-Load) HL 18 D (TRS) Air Top 18
Catalogue Brochure	Accessories for Heaters Accessories Air Ducting
Technical Bulletins	
Webasto Information Publications	

Note

Because the air heaters' exterior is identical in appearance they are marked on their identification label with the designations "Petrol" or "Diesel". Air Top 18 heaters can be identified by the mat grey finish of their housing, the TRS type by a sticker marked with the words "product in accordance with TRGVS/TRS".

The heaters may only be operated with the specified fuel (Diesel version may also use fuel oil EL) and the appropriate electrical power connection.

Electrical components for specific voltages are marked "red" for heaters operating on 12 Volts and "green" for heaters operating on 24 Volts.

Avant-propos

Ce manuel d'atelier doit fournir les informations nécessaires pour se familiariser avec toutes les versions de la série d'appareil de chauffage HL 18 Essence et Gas-oil ainsi que Air Top 18 Essence et Gas-oil. Les appareils de chauffage Air Top sont le perfectionnement des appareils HL. Ce manuel ne remplace pas le stage d'instruction de Webasto, mais dans bien des cas, il sera un conseiller utile lors de la mise en marche initiale ainsi que pour l'entretien, et réparations ou encore pour le montage et le démontage.

Etant donné le nombre et la complexité des détails d'ordre technique, la diversité des champs d'application et l'évolution constante des appareils de chauffage, ce manuel ne peut, à lui seul, aborder tous les problèmes qui se présentent. En cas de besoin, il convient de se référer à d'autres spécifications Webasto telles que :

Les instructions de service	HL 18 B HL 18 D HL 18 D (Charge partielle) HL 18 D (TRS) Air Top 18
Les notices de montage	HL 18 B HL 18 D HL 18 D (Charge partielle) HL 18 D (TRS) Air Top 18
Les listes de pièces de rechange	HL 18 B HL 18 D HL 18 D (Charge partielle) HL 18 D (TRS) Air Top 18
Le catalogue	Accessoires pour appareils de chauffage
La brochure	Accessoires pour systèmes de canalisations d'air
Les informations techniques	
Les informations Webasto	

Remarque

L'aspect extérieur des appareils de chauffage HL 18 B et HL 18 D étant identique, ils seront différenciés par des autocollants portant l'inscription "Essence" ou "Gas-oil". Les appareils de chauffage Air Top 18 sont reconnaissables par leur boîtier gris mat. La version TRS se distingue par l'autocollant "Produit répond au TRGVS/TRS".

Ces appareils de chauffage ne doivent fonctionner qu'avec le carburant prescrit (pour diesel également mazout EL) et ne doivent être branchés que sur le courant électrique prévu pour chaque modèle.

Les éléments électriques sont repérés en "rouge" pour les appareils de chauffage 12 Volts et en "vert" pour les appareils 24 Volts.

CONTENTS

1	Technical Data	10
1.1	Technical Data of Heaters.....	10
1.2	Permissible Diameters and Lengths of Connecting Pipes and Ducts.....	11
1.3	Summary of Heater Variants.....	11
2	General Description	12
2.1	Air Heaters HL 18 B/D.....	12
2.2	Air Heaters Air Top 18.....	13
3	Initial Operation	14
3.1	General Notes.....	14
3.2	Bleeding the Fuel Supply System.....	14
3.3	Combustion Check.....	14
4	Troubleshooting	15
5	Description of Operation	18
5.1	Sequence of Operation (Heaters with Control Unit SG 1559).....	18
5.1.1	Switching on the Heater.....	18
5.1.2	Combustion Operation.....	18
5.1.3	Start after Control Idle.....	18
5.1.4	Switching off the Heater.....	18
5.1.5	Switch-off upon Failure.....	18
5.2	Sequence of Operation (Heaters with Control Unit SG 1561 GT and Control Unit SG 1561 GS, Order No. 24189A).....	19
5.2.1	Switching on the Heater.....	19
5.2.2	Combustion Operation.....	19
5.2.3	Start after Control Idle.....	20
5.2.4	Start of Part-Load Operation (only for HL 18 D).....	20
5.2.5	Start of Full-Load Operation.....	20
5.2.6	Switching off the Heater.....	21
5.2.7	Switch-off upon Failure.....	21
6	Components	22
6.1	Heater Components.....	22
6.1.1	Electric Motor (Drive) with Combustion Air Fan.....	22
6.1.2	Combustion Air Fan.....	23
6.1.3	Combustion Air Adjustment Screw (Grubscrew).....	23
6.1.4	Fuel Connection complete with Fleece (Evaporator).....	24
6.1.5	Glow Plug (not in Air Top!).....	25

6.1.6	Glow Pin (Air Top only)	25
6.1.7	Flame Detector	26
6.1.8	Overheat Switch and Safety Switch	27
6.1.9	Heat Exchanger	29
6.1.10	Burner Tube	29
6.2	Fuel System Components	30
6.2.1	Dosing Pump	30
6.2.2	Fuel Tap	31
6.2.3	Fuel Filter	31
6.2.4	Fuel Tank Tap	31
6.3	Exhaust and Combustion Air System Components	33
6.3.1	Pressure Balancer (Exhaust/Suction Feedthrough)	33
6.3.2	Exhaust Silencer	33
6.3.3	Flexible Exhaust Pipe	33
6.3.4	Combustion Air Pipe	33
6.4	Electrical System Components	34
6.4.1	Control Unit	34
6.4.2	Wiring Harness	37
6.4.3	Glow Plug Dropping Resistor 0.61 Ω (Option)	38
6.4.4	Glow Plug Dropping Resistor 0.27 Ω (Option)	38
6.4.5	Resistor (Part-Load)	38
6.4.6	Pulsing Glow Relay (Option)	39
7	Repair and Disassembly Instructions	40
7.1	General Important Notes for Repairs	40
7.1.1	Removal and Installation of Heater	40
7.1.2	Work on the Vehicle	40
7.1.3	Heater Test Run	40
7.2	Tools and Test Equipment	41
7.2.1	Hose Clamp	41
7.2.2	Test Unit	41
7.2.3	Glow Plug Wrench	41
7.2.4	Test Equipment	42
7.3	Performing Modifications	42
7.3.1	Conversion to a Modified Heat Exchanger with Housing	42
7.3.2	Conversion of Control Unit SG 1559 to Control Unit SG 1561 GT with Integral Glow Pulsing	46
7.4	Disassembly Instructions	52
8	Maintenance	53
8.1	Test and Maintenance Procedures	53
8.2	Functional Test	53
8.3	Spares Provisioning	53
9	Wiring diagrams	142

1 Technical Data

1.1 Technical Data of Heaters

Unless limit values are indicated, the following technical data are subject to the normal tolerances for heaters of approx. ±10% at an ambient temperature of +20 °C and at rated voltage.

Electrical Components:

Control unit, motor, dosing pump, glow plug of HL 18 or glow pin of AirTop 18, part-load resistor (only for HL 18 D and AirTop 18), digital timer (not for TRS), and incandescent lamp (for switch) are either for 12 or 24 Volts operation. The components flame detector, overheat switch, and safety switch are identical in both 12 and 24 Volts heaters.

Heater				HI 18 B	HI 18 D / Air Top 18 + TRS / Part-Load
Test symbol				≈ S194	≈ S192
Design				Air heater with evaporator burner	
Heat output		Full-Load kW Part-Load kW		1,7 (1460 kcal/h) —	1,7 (1460 kcal/h) 1,0 (860 kcal/h)
Fuel				Petrol DIN 51600 DIN 51607	Diesel Fuel DIN 51601 or grades and blends permitted by the engine manufacturer concerned. Fuel oil EL DIN 51603
Fuel consumption		Full-Load kg/h Part-Load kg/h		0,18 (0,23 l/h) —	0,18 (0,20 l/h) 0,10 (0,12 l/h)
Rated voltage			V-	12 or 24	
Operating voltage			V-	10 ... 14 or 20 ... 28	
Rated input (not in starting operation)		Full-Load W Part-Load W		25 —	25 15
Permissible ambient temperature in operation			°C	-40 ... +60	
- control unit			°C	-40 ... +75	
- heater			°C	-40 ... +20	
- dosing pump			°C		
Permissible storage temperature			°C	-40 ... +85	
- control unit			°C	-40 ... +85	
- heater			°C	-40 ... +85	
- dosing pump			°C	-40 ... +85	
Permissible combustion air intake temperature			°C	+40 max.	
Warm air flow		0,5 mbar Full-Load m ³ /h 0,25 mbar Part-Load m ³ /h		55 —	55 41
CO ₂ in exhaust gas (at Full-Load)			Vol. %	9,5 ... 12,0	
- permissible functional range			Vol. %	10,0 ... 10,5	
- adjustment value at rated voltage			Vol. %		
CO in exhaust gas		- legal max. Vol. % - with no wind max. Vol. % - at 100 km/h max. Vol. %		0,2 (2000 ppm) 0,1 (1000 ppm) 0,2 (2000 ppm)	
HC in exhaust gas (at rated load with no wind)			Vol. %	0,01 (100 ppm) max.	
NO _x in exhaust gas (at rated load with no wind)				0,02 (200 ppm) max.	
Smoke No.			- Bacherach - Bosch	< 6,0 < 0,5	
Dimensions Heater: (Tolerance ± 3 mm)		Length mm Width mm Height mm		346 123 130	
Dimensions Dosing Pump: (Tolerance ± 3 mm)		Length mm Width mm Height mm		152 74 70	
Dimensions Control Unit: (Tolerance ± 2 mm)		Length mm Width mm Height mm		97 102 36	97 * 150 * 43,5 *
* Control unit with Support					
Weights		Heater kg Control Unit kg Dosing Pump kg		2,90 0,27 0,35	

Heater Types:

HL 18 B - air heater with petrol fuel

HL 18 D - air heater with Diesel fuel

AirTop 18 with part-load operation - air heater with Diesel fuel

HL 18 D with part-load operation - air heater with Diesel fuel. Control in heating operation with full load or alternatively with partload (reduced heating performance and power consumption)

HL 18 D (TRS), AirTop 18 (TRS) - air heater with Diesel fuel and special installation kit, in particular for use in

1.2 Permissible Diameters and Lengths of Connecting Pipes and Ducts

Fuel line, suction side (see also para. 6.2.4) – Internal diameter – Max. length – Max. suction height	mm m m	3 3 see para. 6.2.4
Fuel line, pressure side – Internal diameter – Max. length – Pressure height	mm m m	2 bis 3 10 see para. 6.2.4
Combustion air intake pipe * – Min. internal diameter – Max. length – Max. bends – min. bending radius	mm m m mm	22 1,5 270° 50
Exhaust pipe * – Min. internal diameter – Max. Length – Max. bends – min. bending radius	mm m m mm	22 1,5 270° 50
Warm air duct – Min. internal diameter – min. bending radius	mm mm	55 see para. 6.5.1

*** Combustion air intake and exhaust lines:**

The total length of the combustion air intake and exhaust lines having an inside diameter of 22 mm in each case may amount to as much as 3000 mm if a silencer is used and to as much as 5000 mm if no silencer is used.

The total angle of bends (smallest bending radius 50 mm) must not exceed 540° for both the combustion air intake line and the exhaust line.

1.3 Summary of Heater Variants

Heater Type	Voltage	Operation	Remarks
HL 18 B.61	12 V	Petrol	with glow plug full load
HL 18 D.01 *	12 V	Diesel	with glow plug full load
HL 18 D.02 *	24 V	Diesel	with glow plug 12V full load
HL 18 D.03 *	24 V	Diesel	with glow plug full load
HL 18 D.05 *	12 V	Diesel	with glow plug full load/part load
HL 18 D.06 *	24 V	Diesel	with glow plug full load/part load
Air Top 18	24 V	Diesel	with glow pin full load/part load
Air Top 18	12V	Diesel	with glow pin full load/part load
Air Top 18 TRS	24V	Diesel	with glow pin full load/part load
HL 18 TRS	24 V	Diesel	with glow plug full load/part load

* Spare only after 01.01.93

2 General Description

2 General Description

2.1 Air Heaters HL 18 B/D

The heater consists of the heat exchanger, burner, and drive assemblies.

The glow plug (6) and the flame detector (7) are secured to the burner head in such a way that they are easily accessible for maintenance. The combustion air fan supplies the required amount of air, which can be adjusted by means of a set screw (refer to para. 6.1.3) and which flows through ports into the burner tube.

The "mixture" formed by evaporation of the fuel on the evaporator (burner fleece) (5) is ignited by the cycled glow plug (6). Heater start is performed under full-load condition. Combustion takes place in the burner tube (9) inserted in the heat exchanger (10).

The overheat switch (8) is secured to the heat exchanger (10). A dosing pump (16) and a control unit (12), e.g. SG 1559 or SG1561 GT, are required to operate the heater.

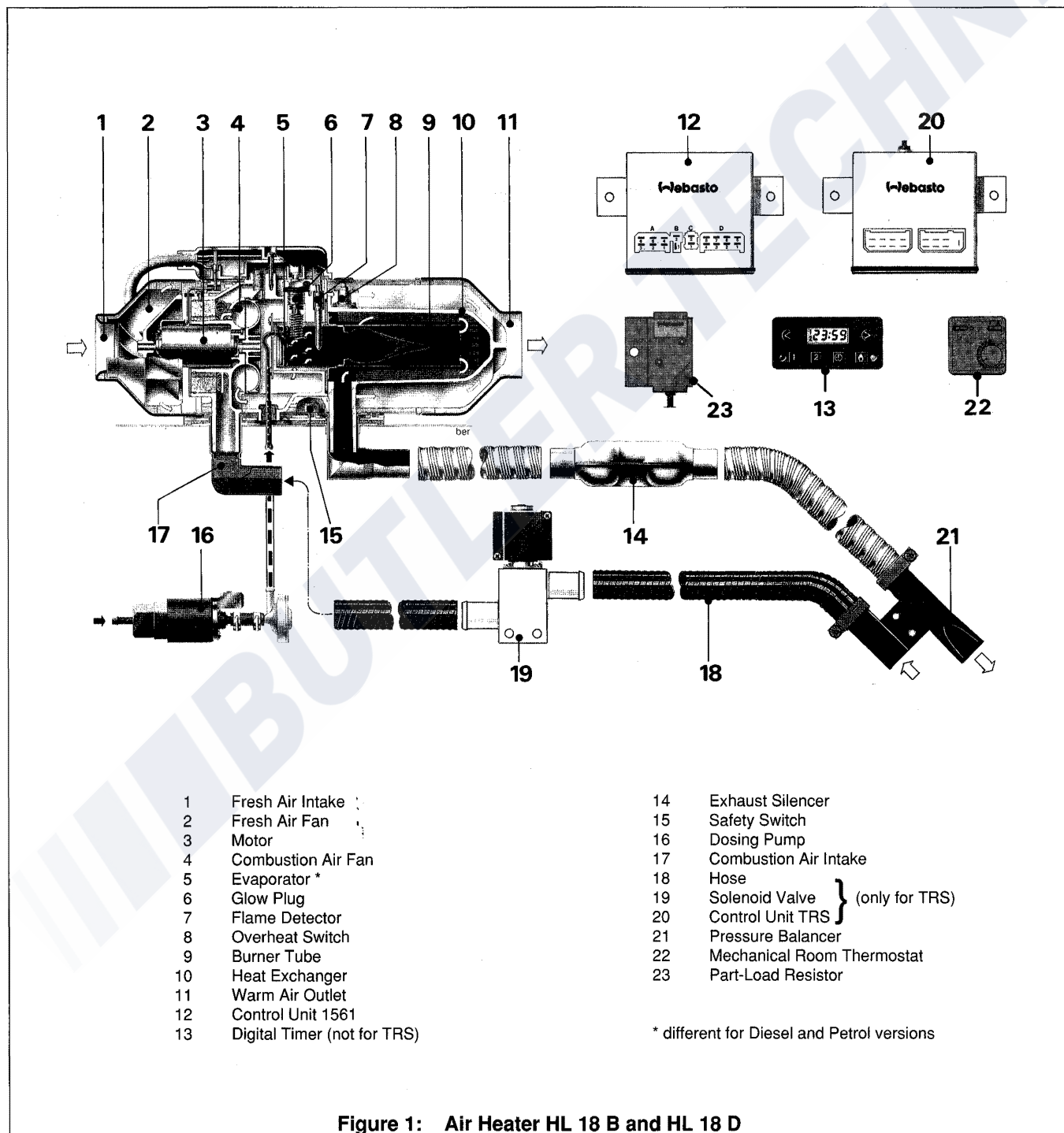

Figure 1: Air Heater HL 18 B and HL 18 D

2.2 Air Heaters Air Top 18

The heater consists of the heat exchanger, burner, and drive assemblies.

The glow plug (6) and the flame detector (7) are secured to the burner head in such a way that they are easily accessible for maintenance. The combustion air fan supplies the required amount of air, which can be adjusted by means of a set screw (refer to para. 6.1.3) and which flows through ports into the burner tube.

The "mixture" formed by evaporation of the fuel on the evaporator (burner fleece) (5) is ignited by the cycled glow pin (6). Heater start is performed under full-load condition. Combustion takes place in the burner tube (9) inserted in the heat exchanger (10).

The overheat switch (8) is secured to the heat exchanger (10). A dosing pump (20) and a control unit (16) are required to operate the heater.

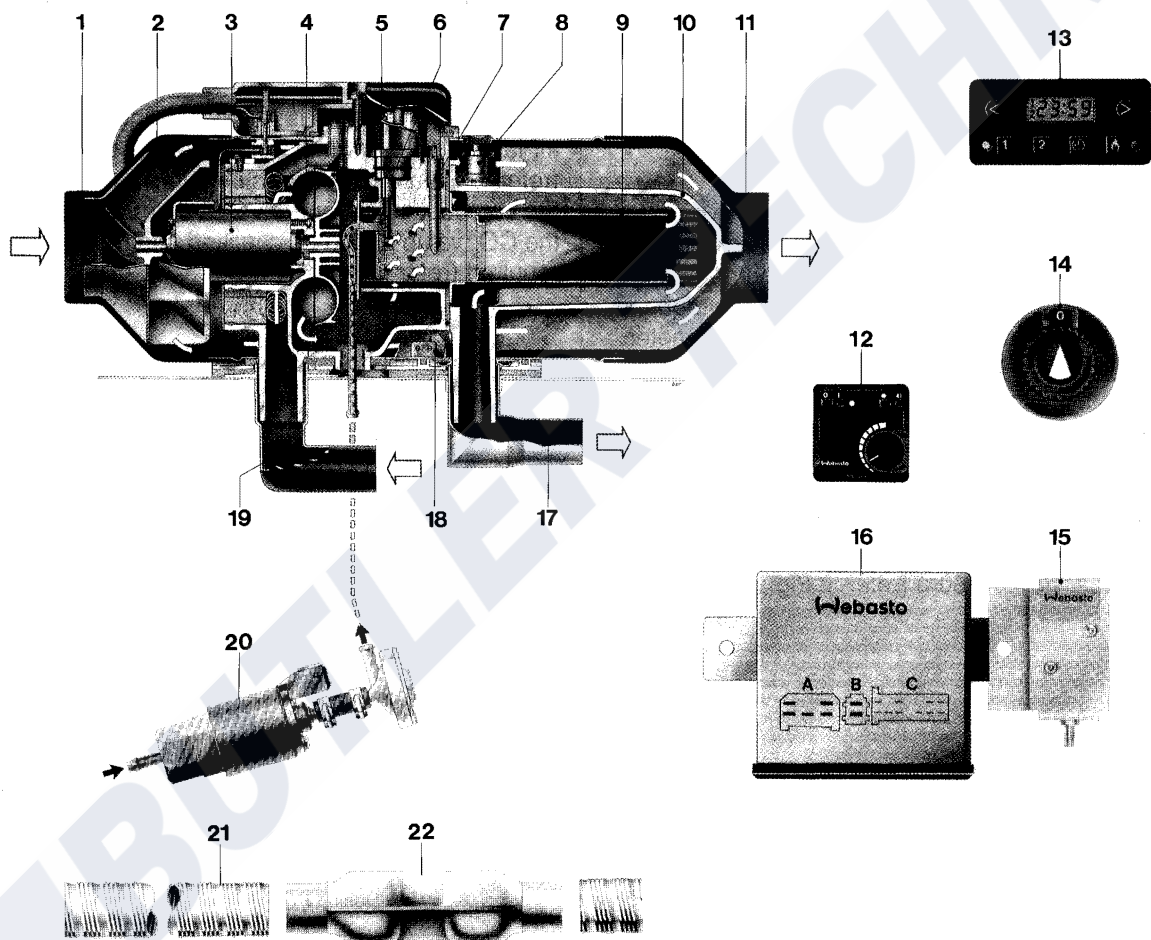

- | | | | |
|----|----------------------------|----|-----------------------------|
| 1 | Fresh Air Intake | 13 | Digital Timer (not for TRS) |
| 2 | Fresh Air Fan | 14 | Switch |
| 3 | Motor | 15 | Part-Load Resistor |
| 4 | Combustion Air Fan | 16 | Control Unit |
| 5 | Evaporator * | 17 | Exhaust Outlet |
| 6 | Glow Pin | 18 | Safety Switch |
| 7 | Flame Detector | 19 | Combustion Air Intake |
| 8 | Overheat Switch | 20 | Dosing Pump |
| 9 | Burner Tube | 21 | Exhaust Tube |
| 10 | Heat Exchanger | 22 | Exhaust Silencer |
| 11 | Warm Air Outlet | | |
| 12 | Mechanical Room Thermostat | | |

* different for Diesel and Petrol versions

Figure 2: Air Heater Air Top 18

3 Initial Operation

3 Initial Operation

3.1 General Notes

After installing the heater, carefully bleed the fuel supply system of the vehicle, observing the guidelines of the vehicle manufacturer.

During test operation of the heater check all connections for leaks and loose fittings. Should the heater enter a failure condition during operation, troubleshooting according to para. 4 is to be performed.

3.2 Bleeding the Fuel Supply System

After heater switch-on the dosing pump must first fill the complete fuel supply system. Should combustion not yet commence upon the first start (including a repeat of the start), the heater has to be switched off and then switched on again (several times if required).

With a completely empty fuel system, the filling time might require in the worst case up to 12 minutes depending on the length of the fuel line and the frequency of the dosing pump (approx. 50 seconds for each meter of fuel line with a diameter of $d = 2 \text{ mm}$).

A quick fill of the fuel supply line might however be achieved as follows:

- the plus connection of the dosing pump is connected with +30 via a push-button switch (e.g. order no. 375.004) (refer to Fig.)

By continuous activation and de-activation the dosing pump is operated until the line is filled.

CAUTION

Do not overfill heater with fuel.

In case of a fuel line sucked empty or a fuel tank emptied by driving the heater should be started several times with the engine running to keep the load on the battery to a minimum.

3.3 Combustion Check

After the heater test run - also after replacement of the combustion air fan - the CO_2 value in the exhaust has to be measured (observe voltage; CO_2 measurement is to be performed only with the vehicle engine running!)

In case the CO_2 value is out of tolerance, the combustion air fan (refer to Para. 6.1.2) or the fuel supply quantity (refer to Para. 6.2.1) has to be checked. When replacing the combustion air fan (drive) and/or the dosing pump, the CO_2 value has to be checked and re-adjusted as required (refer to Para. 6.1.3).

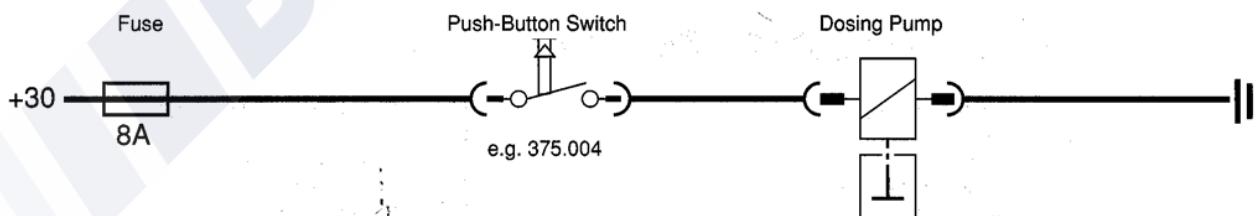

Troubleshooting is facilitated by use of the test unit (refer to para. 7.2.2).

Heater enters "Switch-off upon Failure" condition (only HL 18 B/D with control unit SG 1559 or SG 1561 GT)

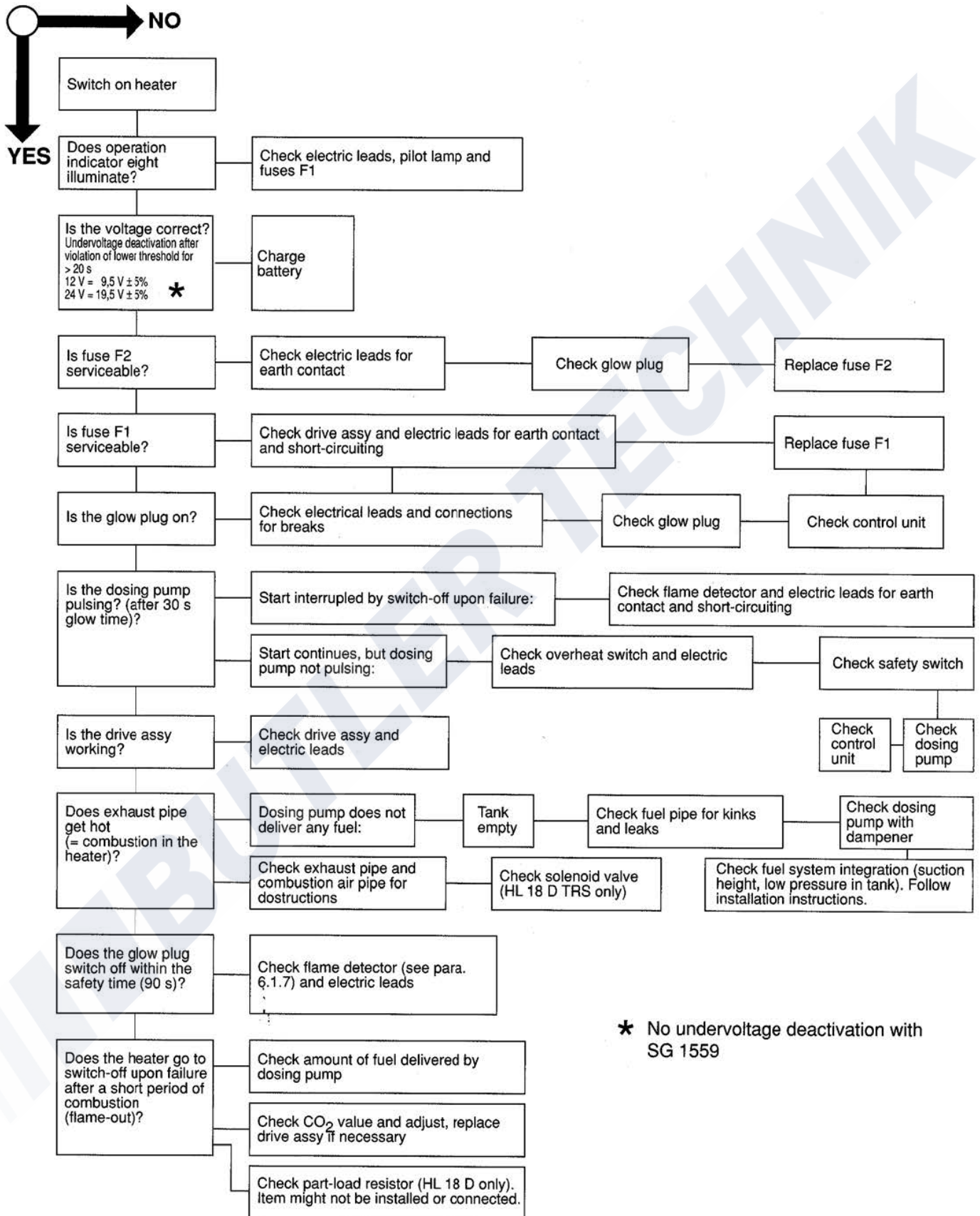

* No undervoltage deactivation with SG 1559

4 Troubleshooting

**Heater in proper operation delivers not enough heat
(only HL 18B/D with control unit SG1559 or SG1561GT)**

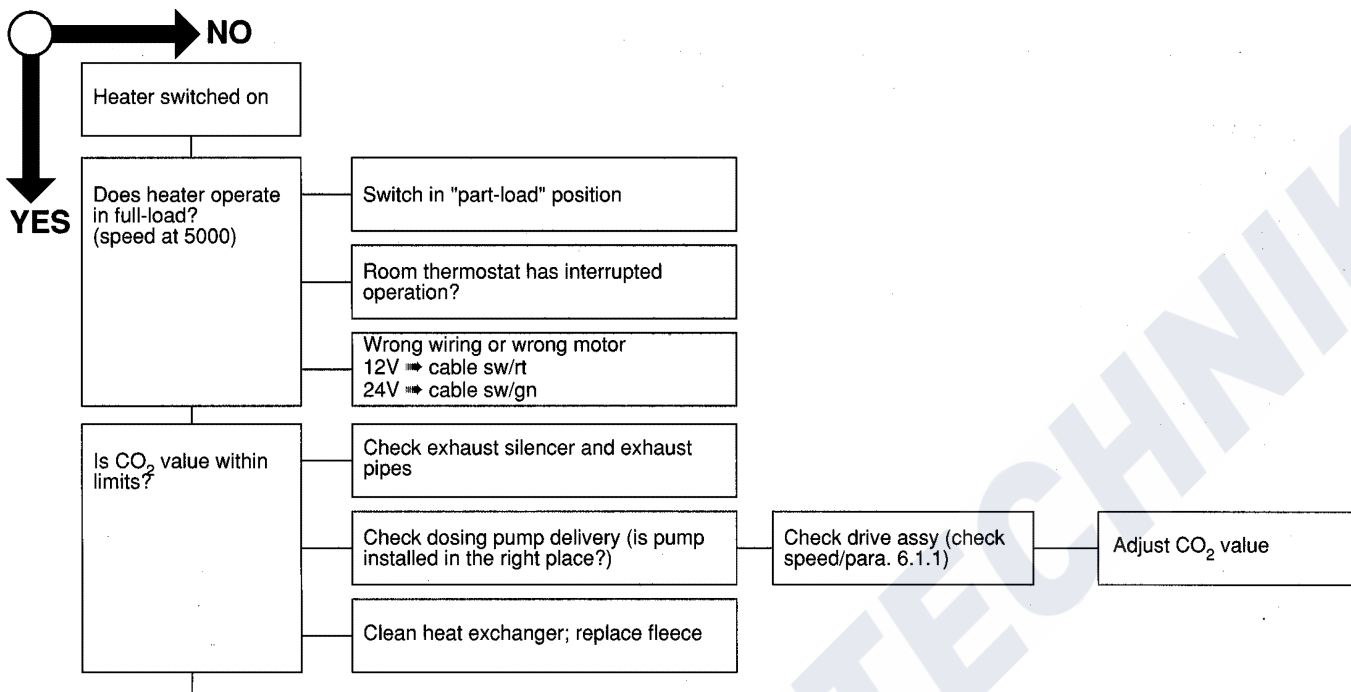

Heater goes to switch-off upon failure during heater operation (only HL 18 B/D)

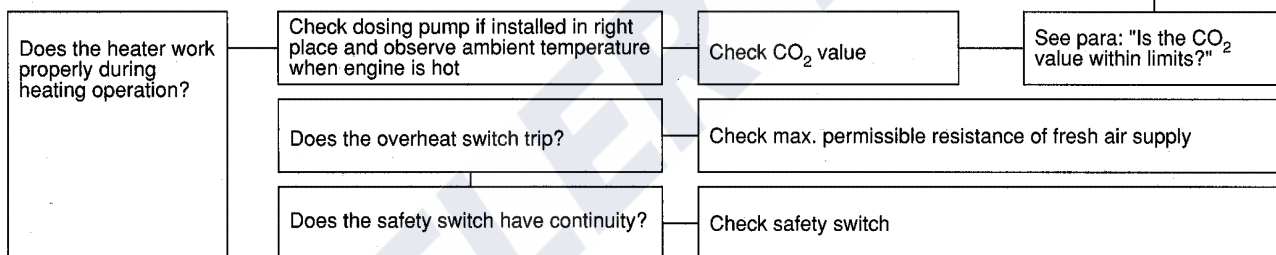

Troubleshooting (quick failure diagnosis)
 (only HL 18 B/D with control unit SG 1559
 or SG 1561 GT or SG 1561 GS)

Fault pattern	Check and, if necessary, repair or replace																
	Electrical supply	Fuses	Electr. wiring and connections (+/-)	Switch	Overheat thermostat	Flame detector	Room thermostat	Electronic control unit	Glow plug (voltage $\leq 9,5$ V)	Operation indicator light	Fuel supply	Dosing pump	Fresh air supply	Combustion air supply	Exhaust venting	Switch (Safety switch)	Part-Load Resistor
Does not work when switched on	●	●	●	●				●	●								
Comb. established only after switching on several times								●		●	●						
No ignition voltage	●	●	●	●		●	●	●									
Low ignition voltage	●	●	●					●									
Motor starts immediately *			●				●										
Motor does not start	●	●	●	●			●		●								
Combustion does not start			●	●			●	●		●	●		●	●	●		
Combustion stops			●	●						●	●	●				●	
Combustion produces white smoke										●							
Combustion produces black smoke									●				●	●			
Heater overheats						●						●					
Motor does not switch off in run-down							●										
Dosing pump pulsing not audible	●	●	●	●	●	●	●				●					●	
Dosing pump pulsing irregular							●				●						
Switch-off upon failure after approx. 360 seconds						●				●						●	
Switch-off upon failure after approx. 80 seconds						●											
Motor stops in Part-Load operation (HL 18 D)			●				●										●

* Possible open circuit glow plug/glow pin (SG 1561 GT and 1561 GS only)

Heater operates immediately without preheating
 (only HL 18 B/D with control unit SG 1561 GT)

Note: Check and replace if required control unit SG 1559 of HL 18 B/D

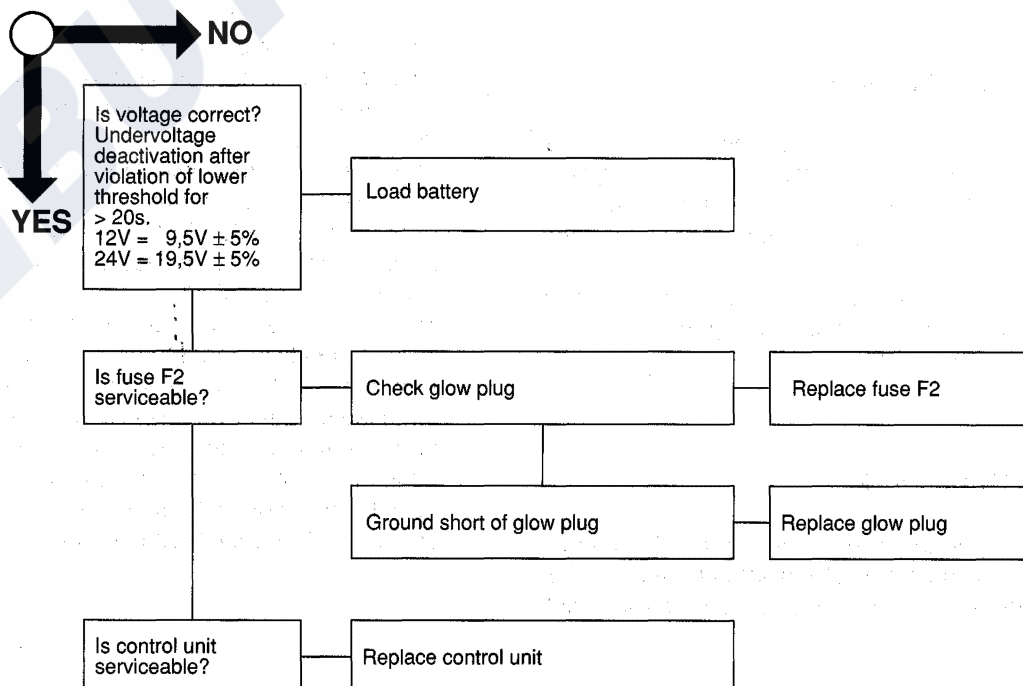

5 Description of Operation

5 Description of Operation

5.1 Sequence of Operation (Heaters with Control Unit SG 1559) (also refer to functional diagram)

The following description refers to circuit diagram B 8014-3000-0001, see 9, circuit diagram page 48.

5.1.1 Switching on the Heater

A positive voltage is permanently applied via fuse F1 to control unit terminal B1 and via F2 to control unit terminal B2. When the heater is switched on, a cycled positive control voltage is also applied via control unit terminal B3 to the electronics of the control unit.

- Operation indicator light H1 illuminates.
- Relay K3 is energised.
- Glow plug is switched on by means of relay K1.
- After glow time (approx. 30 sec) a cycled positive voltage is applied via transistor V101 to control unit terminal A5. Dosing pump Y is supplied from control unit terminal A5 via the overheat switch B2.
- The safety delay time (approx. 90 sec) and preliminary fuel flow period (approx. 5 sec) begin.
- After the preliminary fuel flow period, motor M is switched on via relay K2 and control unit terminal A2.

If combustion is established during the safety delay time, flame detector B1 signals "bright" and relay K1 is de-energised. The safety delay time is reset and the glow plug switched off. This process takes approximately 15 seconds, when ignition is correct.

Repeat start:

If combustion is not established within the safety delay time, a second start attempt is performed automatically (for details refer to functional diagram).

5.1.2 Combustion Operation

The heater, now in operation, continues to operate until control voltage at control unit terminal B3 is interrupted. This is caused either by manual manipulation or by the preset operating time limitation of timer P or by the room thermostat.

Note: Depending on the heat requirement the heater may remain in "combustion" or "control idle" (means heater off) condition for some time.

5.1.3 Start after Control Idle

If the heater is operated with a room thermostat, a new starting process is automatically initiated (refer to 5.1.1) as soon as the room thermostat drops below the preset temperature.

5.1.4 Switching off the Heater

When the heater is switched off manually or via the preset timer P, operation indicator light H1 extinguishes. If the heater is switched off by the room thermostat, operation indicator light H1 remains illuminated during the control idle period.

- Dosing pump Y is switched off.
- Run-down cycle starts immediately.

5.1.4.1 Run-down Cycle

The run-down cycle comprises of the cool-down period of the flame detector (approx. 20 sec) and an electrical run-down of 60 sec. If the flame detector does not signal "dark" after 80 sec, the electrical run-down of 60 sec is initiated by the control unit thereby switching off the heater in any case after 140 sec.

During the run-down cycle the drive assembly continues operation. The run-down ventilates and degasses the combustion chamber and cools down the heat exchanger in order to prevent damage by overheating.

At the end of the run-down cycle relay K2 is de-energised and motor M stops. The heater is now off.

5.1.5 Switch-off upon Failure

The heater automatically stops operation in case of failure condition. Operation indicator light H1 remains illuminated. The control unit in "switch-off upon failure" condition can be reset by switching it off (it must remain off for at least 1 sec) after rectification of the fault.

5.1.5.1 Switch-off upon Failure after No Flame Condition

- For switch-on refer to 5.1.1.
- If combustion is not established during the safety delay time, relay K2 is de-energised after 90 sec, the motor M stops.
- The cycled voltage applied to control unit terminal A5 via transistor V101 is removed.
- After approximately 30 sec of glow time, the cycled positive voltage is re-applied via transistor V101 to control unit terminal A5.
- The safety delay time (approx. 90 sec) and preliminary fuel flow period (approx. 5 sec) commence.
- After the preliminary fuel flow period, motor M is switched on again via relay K2 and control unit terminal A2 and a second start attempt commences. If during this second start attempt combustion is not established within the safety delay time, the control unit enters the "switch-off upon failure" condition.

5.1.5.2 Switch-off upon Failure after Flame-out (e. g. lack of fuel)

If a flame-out occurs during combustion and/or the flame detector B1 signals "dark", the glow plug is activated by means of relay K1 for a maximum of 90 sec (safety delay time). If combustion is re-established, the heater is again in normal combustion mode, refer to 5.1.2.

If combustion is not achieved, the motor, dosing pump, and glow plug are switched off after 90s sec safety delay time. The control unit enters the "switch-off upon failure" mode.

Sequence of Operation (Functional Diagram Control Unit) Normal Operation for Heaters with Control Unit SG 1559

- ① Switch-on
- ② Preheating 30 sec
- ③ Fuel Feed 5 sec
- ④ Start
- ⑤ Safety Delay Time 90 sec
- ⑥ Combustion (safety delay time is interrupted)
- ⑦ Control Idle Start
- ⑧ Run-down max. 140 sec
- ⑨ Run-down 60 sec
- ⑩ Control Idle End
- ⑪ Switch-off
- ⑫ Off

* If combustion is not established, repeat starting takes place automatically (30 sec preheating, 90 sec safety delay time).

5.1.5.3 Switch-off upon Failure by Overheating

If overheating occurs, overheat switch B2 cuts off the power supply to the dosing pump. This stops fuel delivery and the flame extinguishes. The sequence of operation then continues as described in para. 5.1.5.2. Before the heater is switched on again, the overheat switch must be reset by pushing it in.

5.1.5.4 Switch-off upon Failure after Preheating and Defective Flame Detector

If the flame detector signals "bright" at the end of the preheating time (30 sec), the control unit enters the "switch-off upon failure" mode.

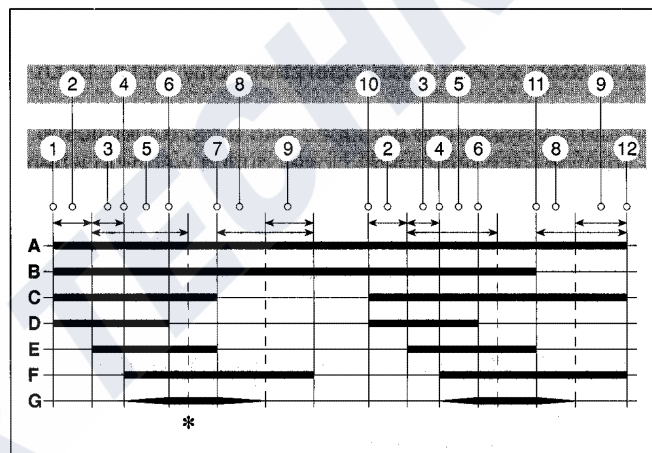

- A Relay K3
B Operation Indicator Light (in item P)
C Room Thermostat (for appl. example see Page 49)
D Relay K1 for Glow Plug
E Transistor V101 for Dosing Pump
F Relay K2 for Motor M
G Flame Detector B1

5.2 Sequence of Operation (Heaters with Control Unit SG 1561 GT and Control Unit SG 1561 GS, Order No. 24189A) (also refer to functional diagram)

The following description refers to the wiring diagrams, see 9, Pages 50 to 63.

5.2.1 Switching on the Heater

A positive voltage is permanently applied via fuse F1 to control unit terminal A2 and via F2 to control unit terminal A1. When the heater is switched on, a cycled positive control voltage is also applied via control unit terminal A6 to the electronics of the control unit.

- Operation indicator light illuminates.
- Relay K4 is energised.
- Glow plug is switched on by means of relay K1 and is cycled depending on the input voltage.
- After glow time (approx. 30 sec) a cycled positive voltage is applied via transistor V101 to control unit terminal D3 (SG 1561 GT) or C10 (SG 1561 GS). Dosing pump Y is supplied via overheat switch B2 and safety switch S3.
- The safety delay time (approx. 90 sec) and preliminary fuel flow period (approx. 5 sec) begin.

- After the preliminary fuel flow period, motor M is switched on again via relay K2 and control unit terminal D1/C4.

If during the safety delay time a flame is available, the flame detector B1 signals "bright" and relay K1 de-energises. The safety delay time is reset and the glow plug or glow pin is switched off. This process requires approx. 15 sec when ignition is correct.

Note: On Air Top heaters with control unit 1561 GS the motor starts after an instant breakaway in part-load and switches to full load after 20 seconds.

Repeat start:

If combustion is not established within the safety delay time, a second start attempt is performed automatically (for details refer to functional diagram).

5.2.2 Combustion Operation

The heater, now in operation, continues to operate until control voltage at control unit terminal A6 is interrupted. This is caused either by manual manipulation or by the preset operating time limitation of timer P or by the room thermostat.

Note: Depending on the heat requirement the heater may remain in "combustion" or "control idle" (means heater off) condition for some time.

5 Description of Operation

5.2.3 Start after Control Idle

In case the heater is operated with a room thermostat, a new start cycle is automatically initiated as soon as the room temperature drops below the switching threshold. The operation indicator light is illuminated during the complete control idle period.

Heaters HL 18B/D (with glow plug) always start in full-load operation.

Air Top heaters (with glow pin) start after an initial breakaway in part-load and then switch to full-load after 20 seconds. After a minimum full-load operating time of 60 seconds, the part-load operation is resumed depending on the switch position of the room thermostat.

5.2.4 Start of Part-Load Operation (only for HL 18 D)

Should the system be equipped with a room thermostat B3 (option), the thermostat closes during warm-up when

Sequence of Operation (Functional Diagram Control Unit) Normal Operation for Heaters with Control Unit SG 1561 GT

Heaters HL 18 B/D without Part-Load Operation

- ① Switch-on
- ② Preheating 30 sec (cycled)
- ③ Fuel Feed 5 sec
- ④ Start
- ⑤ Safety Delay Time 90 sec
- ⑥ Combustion (safety delay time is interrupted)
- ⑦ Control Idle Start
- ⑧ Optical Run-down max. 80 sec
- ⑨ Electrical Run-down 90 sec
- ⑩ Control Idle End
- ⑪ Switch-off
- ⑫ Off

* In combustion is not established, repeat starting takes place automatically (30 sec preheating, 90 sec safety delay time).

Heaters HL 18 B/D with Part-Load Operation

- ① Switch-on
- ② Preheating 30 sec (cycled)
- ③ Fuel Feed 5 sec
- ④ Safety Delay Time 90 sec
- ⑥ Combustion - Full-Load
- ⑦ Room Temperature (rated value reached)
- ⑧ Switch-over from Full-Load to Part-Load (20 sec)
- ⑨ Combustion - Part-Load
- ⑩ Room Temperature (below rated value)
- ⑪ Switch-over from Part-Load to Full-Load (10 sec)
- ⑫ Switch-off
- ⑬ Optical Run-down max. 80 sec
- ⑭ Electronic Run-down max. 90 sec
- ⑮ Off
- ⑯ Minimum Full-Load Operating Time 60 sec (no interruption possible)

* If combustion is not established after start of operation, repeat starting takes place automatically (30 sec preheating, 90 sec safety delay time).

reaching the set room temperature. A positive control voltage is applied to terminal A3. The dosing pump cycles with the low frequency for part-load. After 20 sec also the motor M operates with the lower part-load operating speed. The heater now operates in low performance until the room thermostat B3 has reached its lower switching point.

During the complete part-load phase the operation indicator light remains on.

5.2.5 Start of Full-Load Operation

When room temperature has reached the lower switching point of the room thermostat B3, the thermostat opens. Terminal A3 is no longer supplied with a positive control voltage and the dosing pump Y cycles with the higher frequency for full-load operation. After 10 sec also the motor M switches back to the higher full-load operating speed.

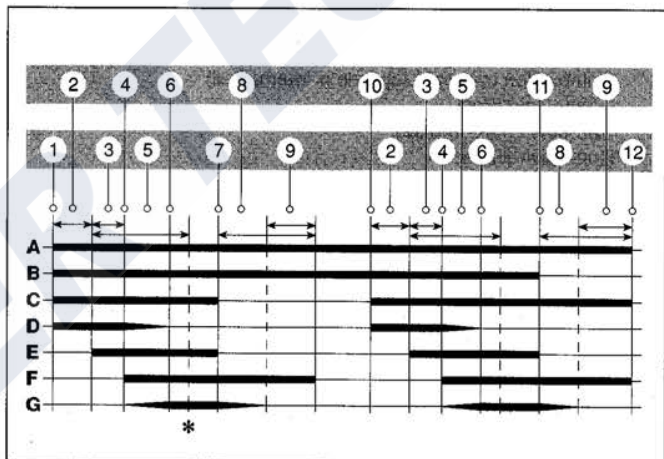

- | | |
|--------------------------------------|-----------------------------------|
| A Relay K3 | E Transistor V101 for Dosing Pump |
| B Operation Ind. Light (in item P) | F Relay K2 for Motor M |
| C Room Thermostat | G Flame Detector B1 |
| D Glow Plug (glow current is cycled) | |

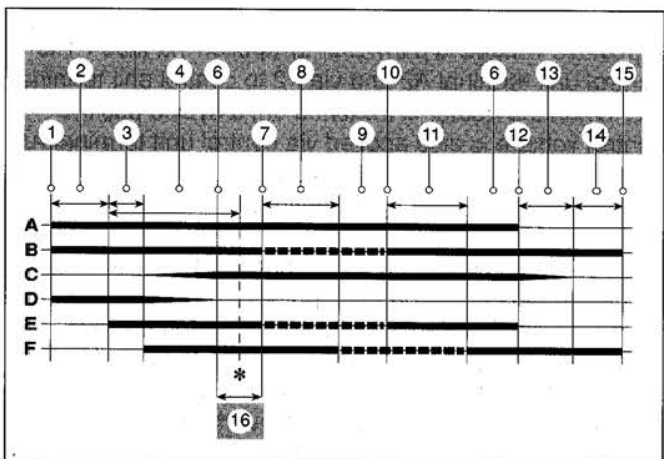

- | | |
|---|--|
| A Operation Ind. Light | D Glow Plug (glow current is cycled) |
| B Part-Load Switch or Room Thermostat (full-load/part-load) | E Dosing Pump (full-load/part-load) |
| C Flame Detector | F Combustion Air Fan (full-load/part-load) |

5.2.6 Switching off the Heater

When the heater is switched off manually or via the preset timer P, operation indicator light H1 extinguishes.

- Dosing pump Y is switched off.
- Run-down cycle starts immediately in full-load operation.

5.2.6.1 Run-down Cycle

The run-down cycle comprises of the cool-down period of the flame detector (approx. 20 sec) and an electrical run-down of 90 sec. If the flame detector does not signal "dark" after 80 sec, the electrical run-down of 90 sec is initiated by the control unit thereby switching off the heater in any case after 170 sec.

During the run-down cycle the drive assembly continues with maximum operation. The run-down ventilates and degasses the combustion chamber and cools down the heat exchanger in order to prevent damage by overheating.

At the end of the run-down cycle relay K2 is de-energised and motor M stops. The heater is now off.

For HL 18 D (TRS) only

The short run-down is automatically initiated when

- the heater is switched off normally,
- the vehicle engine is switched off (D+/61 no longer supplied with voltage),
- a delivery installation is put into operation, whereby the solenoid valve in the combustion air line closes after 20 sec, the air fan however continuing run-down operation for a max. of 170 sec.

5.2.7 Switch-off upon Failure

The heater automatically stops operation in case of failure condition. Operation indicator light H1 remains illuminated until switch-off with the master switch or the digital timer. The control unit in "switch-off upon failure" condition can be reset by switching it off (it must remain off for at least 1 sec) after rectification of the fault.

5.2.7.1 Switch-off upon Failure after No Flame Condition

- For switch-on refer to 5.2.1.
- If combustion is not established during the safety delay time, the cycled voltage to control unit terminal D3 (SG 1561 GT) or C10 (SG 1561 GS) via transistor V101 is removed
- After approximately another 30 sec of (afterglow time), relay K2 is de-energised, motor M stops.
- After approx. 30 sec preheating again cycled positive voltage is re-applied to control unit terminal D3 (SG 1561 GT) or C10 (SG 1561 GS) via transistor V101.
- The safety delay time (approx. 90 sec) and preliminary fuel flow period (approx. 5 sec) commence.

- After the preliminary fuel flow period, motor M is switched on again via relay K2 and control unit terminal D1/C4 and a second start attempt commences. If during this second start attempt combustion is not established within the safety delay time, the control unit enters the "switch-off upon failure" condition.
- The heater run-down cycle is initiated.

5.2.7.2 Switch-off upon Failure after Flame-out (e. g. lack of fuel)

If a flame-out occurs during combustion and/or the flame detector B1 signals "dark", the glow plug is activated by means of relay K1 for a maximum of 90 sec (safety delay time). If combustion is re-established, the heater is again in normal combustion mode, refer to 5.2.2.

If combustion is not achieved, the dosing pump and glow plug are switched off after 90s sec safety delay time. The control unit enters the "switch-off upon failure" mode. The heater run-down cycle is initiated.

5.2.7.3 Switch-off upon Failure by Overheating

If overheating occurs, overheat switch B2 cuts off the power supply to the dosing pump. This stops fuel delivery and the flame extinguishes. The sequence of operation then continues as described in para. 5.2.7.2. Before the heater is switched on again, **the overheat switch must be reset by pushing it in.**

5.2.7.4 Switch-off upon Failure by Opening of Safety Switch S3

If the heater is not secured properly in its support, S3 interrupts the power supply to the dosing pump. For further sequence of operation refer to 5.2.7.3.

5.2.7.5 Switch-off upon Failure after Preheating and Defective Flame Detector

If the flame detector signals "bright" at the end of the preheating time (30 sec), the control unit enters the "switch-off upon failure" mode with a run-down cycle.

5.2.7.6 Switch-off upon Failure TRS (for HL 18 D-TRS only)

After release of a TRS switch-off there will be a run-down with the control unit subsequently entering the "switch-off upon failure" mode. Before a re-start the On/Off switch must be selected "Off".

The switch S2 may be operated only in case of emergency, as the heater is switched off without run-down.

6 Components

6.1 Heater Components

6.1.1 Electric Motor (Drive) with Combustion Air Fan

Description: The electric motor is a permanent magnet motor for driving both the fresh air fan and the combustion air fan. Both fans are mounted to the electric motor.

A combustion air adjustment screw is provided on the housing. The resistor of the part-load unit is separately mounted next to the control unit.

Test: The function of the combustion air fan and the electric motor can be tested using the test unit.

Test of motor revolutions with motor installed and at rated voltage:

	HL 18 B/D	AirTop 18 B/D
FL	5000 min ⁻¹ (±10%)	5000 min ⁻¹ (±10%)
PL	3800 min ⁻¹ (±10%)	3800 min ⁻¹ (±10%)

During test check for grinding noises.

Revolutions of

FL	4400 < min ⁻¹	4400 < min ⁻¹
PL	3350 < min ⁻¹	3350 < min ⁻¹

require the replacement of the combustion air fan with electric motor.

If the CO₂-value cannot be adjusted to the permissible value (at rated voltage 10.0... 10.5 Vol.%), the fuel supply rate is to be checked (refer to 6.2.1). Should the supply rate of the dosing pump be within its limits, the combustion air fan is to be replaced.

Rated measure for gap between housing and blade wheel = 0.3 + 0.1 mm

Caution: Other measures require replacement of combustion air fan.

Removal:

- Remove cap (wiring harness) (Phillips screwdriver)
- Remove seal from connector terminals
- Electrically disconnect flame detector (flame detector remains in housing)
- Remove covers (inlet and outlet) (Phillips screwdriver)
- Separate upper and lower housing half shells
- Unclip top of connector from bottom of connector (screwdriver; disconnect connector terminals for overheat switch and drive assembly).

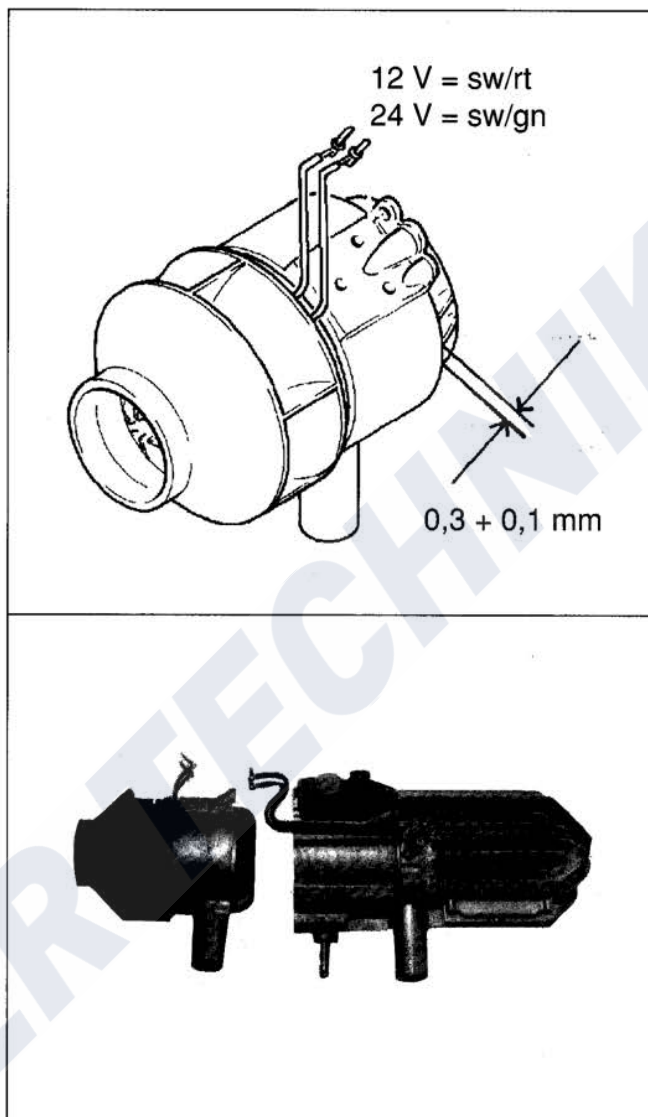

- Remove clamps from wiring harness and safety switch and remove safety switch.
- Dismount drive from housing (Phillips screwdriver)

Installation: Proceed in reverse order of disassembly. As an aid for assembly a hose clamp with clamp diameter D₁ = 120 mm (Webasto Order No. 139.653) may be used to hold the two halves of the casing together.

Torque (drive) : 30 Nm

Electrical connection according to circuit diagram.

The gasket below the cap (wiring harness) as well as the connector must be replaced. When fitting cap secure with a torque of 0.5 Nm.

Note: After replacement of drive assembly the CO₂-value must be measured and readjusted as required (for adjustment procedure/adjustment value refer to 6.1.3 "Combustion Air Adjustment Screw").

6.1.2 Combustion Air Fan

Description: The combustion air fan is integral part of the drive assembly (refer to 6.1.1). It is a highly accurate circular duct fan for supply of the combustion air for the heater.

Test: Check motor revolutions (refer to 6.1.1). Check CO₂-value (refer to 6.1.3).

Removal/Installation: As for drive assembly (refer to 6.1.1).

Repair: The combustion air fan cannot be repaired. The complete drive assembly must be replaced.

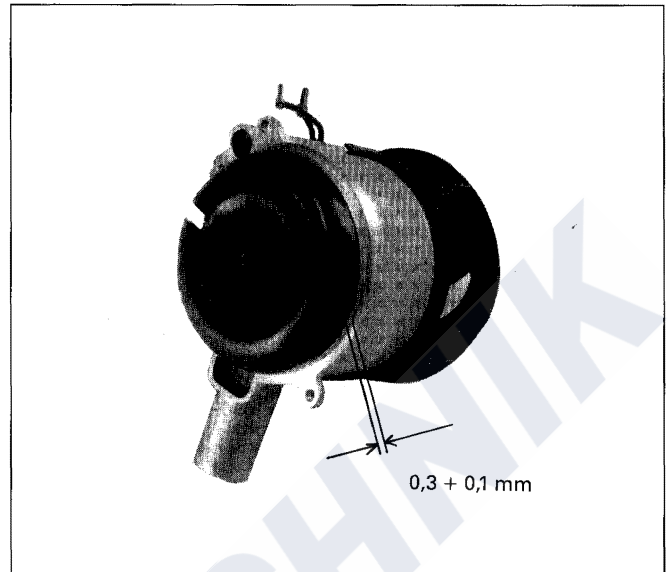

6.1.3 Combustion Air Adjustment Screw (Grubscrew)

Description: The combustion air adjustment screw is used for precise adjustment of the ratio of combustion air to the fuel delivered by the dosing pump (CO₂-setting).

Test/Repair: The combustion air adjustment screw is self-locking. It must be replaced if it is too loose.

CO₂-Setting: After replacing the drive assembly (refer to 6.1.1) or the dosing pump (refer to 6.2.1) the CO₂-value must be measured and re-adjusted as required.

CO₂-Adjustment Value: Outside the admissible operating range, the CO₂-value must be set to 10-10.5% at rated voltage by corrective setting of the combustion air adjustment screw.

A screwdriver is used as tool (refer to Figure).

Caution: The combustion air adjustment screw is set for the specified CO₂-value in the factory. Any re-adjustment may only be carried out after replacement of the dosing pump or the drive assembly, or when the combustion air fan is not operating properly.

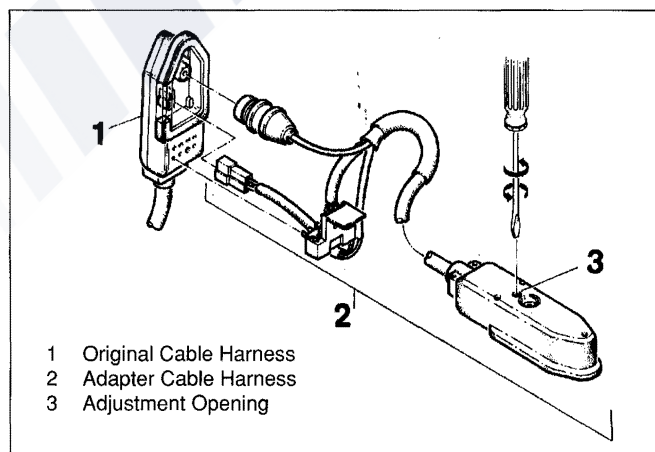
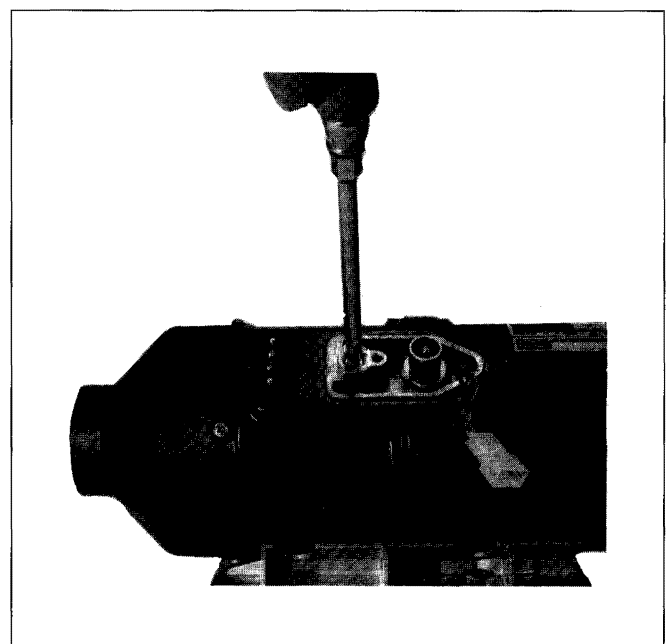
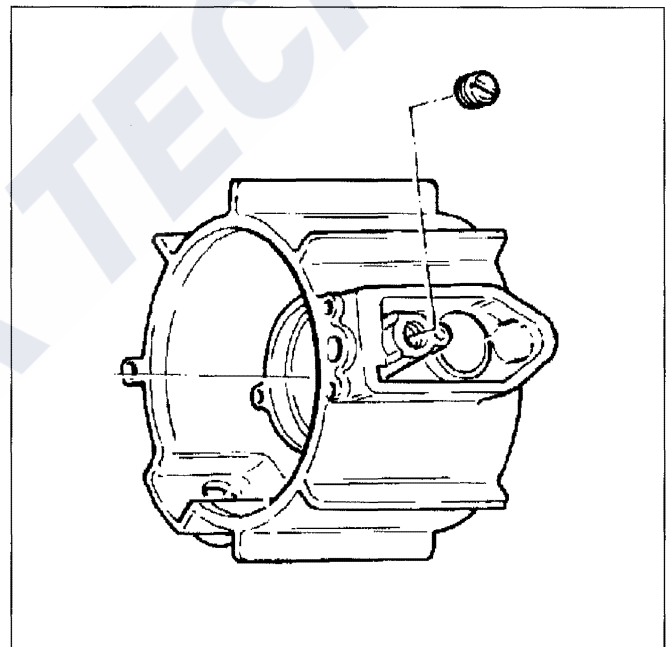

6 Components

Adjustment Procedure: Clockwise rotation: CO₂-value decreases (before measuring allow heater to operate for approx. 5 min; heater must be switched off for adjustment without adapter cable harness).

Coarse Adjustment: Screw in adjustment screw until flush with housing.

Note: For adjustment with adapter cable harness the heater does not have to be in switched-off condition. The adapter cable harness has to be connected according to the Figure.

Caution! The adapter cable harness must not remain in the vehicle.



6.1.4 Fuel Connection complete with Fleece (Evaporator)

Description: The fuel connection represents the end of the burner tube. The fuel is fed to the combustion chamber through the tube via the fleece (different for petrol and Diesel).

Removal:

- Remove drive assembly (refer to 6.1.1).
- Loosen screws on fuel connection (Phillips screwdriver).
- Remove fuel connection.
- Remove fleece.

Test/Repair:

- Check fuel connection for obstructions and leaks.
- Fit new fleece.

Caution: On petrol version do not remove displacement wire?

Installation: Proceed in reverse order of removal. The fleece must be renewed every time the connection is installed. The fleece **must not** be glued into position. The sealing surface (A) between the fuel connection and the housing must be coated with sealing compound CURIL T (refer to Spare Parts List).

Note: The fleece is different for the HL 18 B and HL 18 D. When the fleece is replaced, ensure that the correct fleece is used (use genuine Webasto spares only).

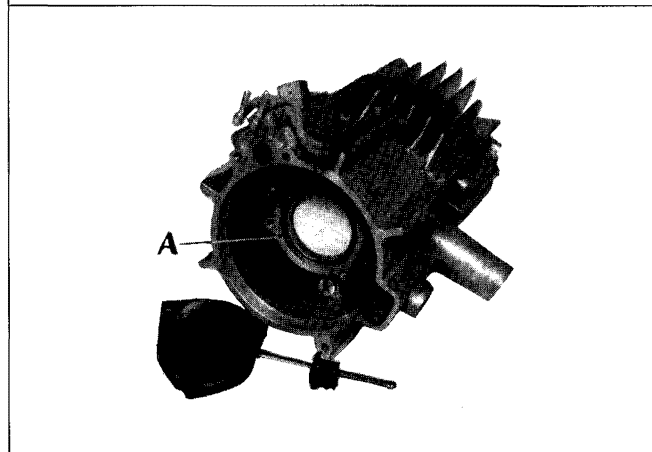
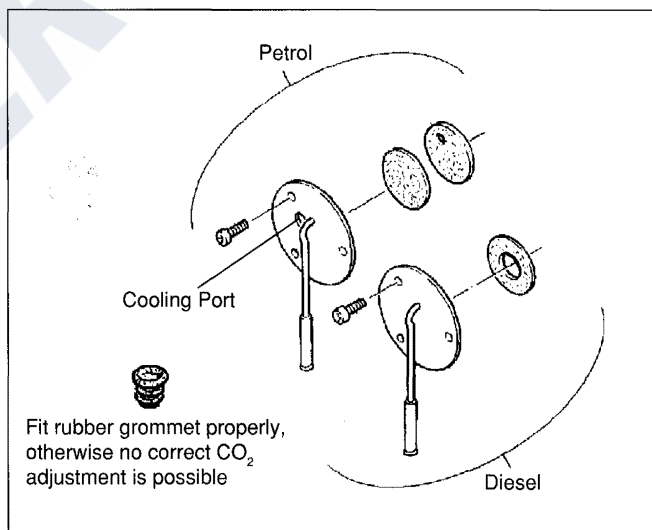

6.1.5 Glow Plug (not in Air Top!)

Description: The filament of the glow plug ignites the fuel-air mixture during the start of the heater. Glow plug protective resistors might decrease the filament temperature (refer to 6.4.1).

Removal:

- Remove cap (wiring harness) (Phillips screwdriver).
- Remove seal from connector terminals.
- Unscrew glow plug and remove (19 mm socket spanner)

Test: Power consumption

	Test voltage	Power consumption
12 V	12 ± 0,2 V	max. 22 A
24 V	24 ± 0,2 V	max. 15 A

Any carbon deposits on the glow plug must be removed by glowing the plug and careful cleaning, replace glow plug if required.

Note: A glow plug with carbon deposits may indicate irregular combustion. In this case the CO₂-adjustment and the combustion values (refer to 6.1.3) must be checked.

Note for Glow Plug Replacement

Due to the manufacturing process the glow plugs of the 12 Volt type and 24 Volt type are nearly identical. For clear identification the most distinctive features are illustrated and listed in the table below including volt/ampere and torque values.

Installation: Proceed in reverse order of removal. When screwing in glow plug torque to 30 Nm and apply Copaslip to thread. When securing cap (wiring harness) apply a torque of 0.5 Nm.

6.1.6 Glow Pin (Air Top only)

Description: The glow pin ignites the fuel-air mixture during the start of the heater.

Removal:

- Remove cap (wiring harness) (Phillips screwdriver).
- Remove seal from connector terminals.
- Remove screw (Phillips screwdriver) and withdraw glow pin.

Test: During electrical test using a digital multimeter the glow pin values must be the following:

Glow Pin	12 V (red)	24 V (green)
Resistance 24 °C	0,290...0,340 Ohm	1,2...1,4 Ohm
Test current	< 5 mA	< 5 mA

Installation: Proceed in reverse order of removal. When securing cap (wiring harness) apply a torque of 0.5 Nm.

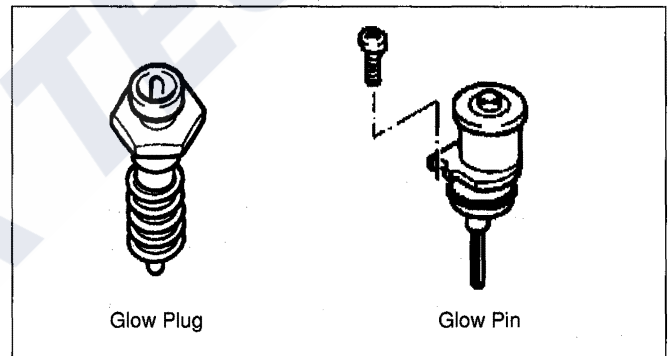

Caution: Glow plugs shall be handled with care and not be unpacked before use.

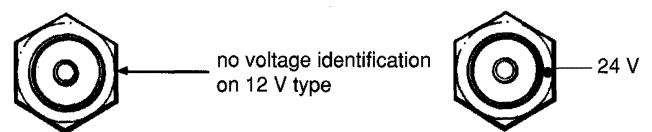

Ident-No. 479594 12V

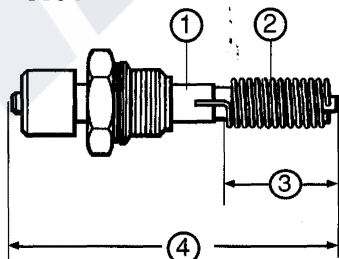

Ident-No. 157915 24V

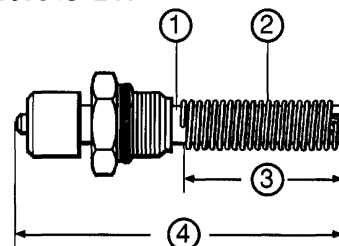

Volt max.	Ampere	Torque value	Length of Sleeve ①	Wire Gauge ②	Length of Filament ③	Total length ④
12	20	28 Nm	approx. 7 mm	1.1 mm	approx. 20 mm	64.5 ± 1 mm
24	13,3	28 Nm	approx. 3 mm	0.8 mm	approx. 30 mm	64 ± 1 mm

6 Components

6.1.7 Flame Detector

Description: The flame detector consists of a phototransistor protected by a tube. After flame-up the tube begins to glow so that the flame detector signals "flame".

The flame detector has the following functions:

- switch off the glow plug (refer to para. 6.1.5) or glow pin (refer to para. 6.1.6) after flame-up.
- initiate a repeat start via the control unit in case of a no-flame condition.
- switch off the heater in case of a flame-out.

Test: Switch on heater -

- If heater transits to switch-off upon failure (without run-down) after approx. 30 sec, there is a short-circuit in the electrical wiring or in the flame detector.
- If heater switches off after successful start and combustion operation of approx. 120 sec to perform a repeat start and then enters the switch-off upon failure state (without run-down) after a total of 240 sec, there is an open circuit to the flame detector or a flame detector internal defect.

Removal:

- Remove cap (wiring harness) (Phillips screwdriver).
- Electrically disconnect flame detector.
- Remove flame detector. Pieces of flame detector in combustion chamber may remain in the chamber.

Repair: The flame detector cannot be repaired and must be replaced as a complete assembly.

Installation: Prior to fitting the flame detector, the O-ring must be seated on the tip of the flame detector and thus be pressed into the hole (apply Copaslip to O-ring). Then refit cap (wiring harness)(torque 0.5 Nm).

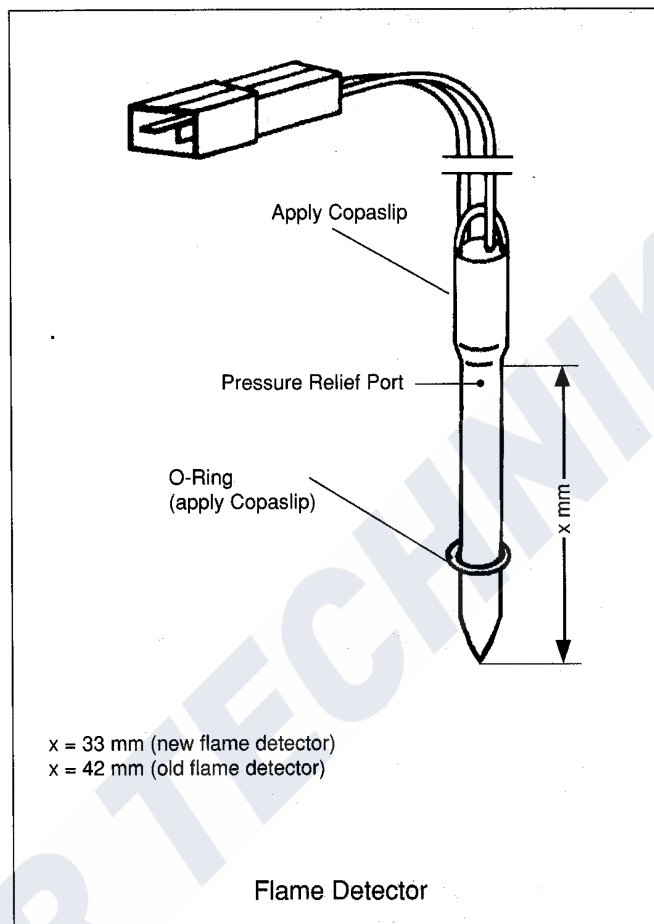

6.1.8 Overheat Switch and Safety Switch

6.1.8.1 Overheat Switch

Description: The overheat switch protects the heater from undue high operating temperatures. When the permissible temperature is exceeded, the overheat switch cuts off the power supply to the dosing pump. The heater changes to the "switch-off upon failure" operating condition due to flame-out.

Test: After manual reset the overheat switch is closed in its cold state (electrical continuity). It opens as the temperature rises to $170 + 9 \text{ }^{\circ}\text{C}$ and does not reset automatically. The sensing surface of the overheat switch predominantly reacts upon radiated heat, i.e. between sensing surface and heat exchanger there must be a gap (refer to relevant Figure).

6.1.8.2 Safety Switch

Description: The switch deactivates - in case the heater is not properly secured in its support - the dosing pump and thus the heater.

Test: Check for electrical continuity. The switch cannot be repaired and has to be replaced as complete assembly.

Removal:

- Remove cap (wiring harness) (Phillips screwdriver).
- Remove seal from connector terminals.
- Electrically disconnect flame detector (flame detector remains in housing).
- Remove covers (inlet and outlet) (Phillips screwdriver).
- Remove upper and lower housing half shells.
- Remove connector terminals for overheat switch from plug upper part.
- Remove cable clamps (cable to safety switch) from motor (Phillips screwdriver).
- Remove safety switch from intermediate housing (Phillips screwdriver).
- Carefully lever off the two lock washers (do not damage spigots) and remove.
- Remove overheat switch.

Repair: The overheat switch cannot be repaired and has to be replaced as a complete assembly. The heater has to be removed for switch replacement.

Installation: The washers (Viton) or serrated washers (metal) located between heat exchanger and overheat switch influence the overheat switch switching characteristics.

When using the "proper" washers the switching range of the overheat switch is corrected, thus preventing a premature response. Noncompliance may cause heat exchanger damage, i.e. it may burn out.

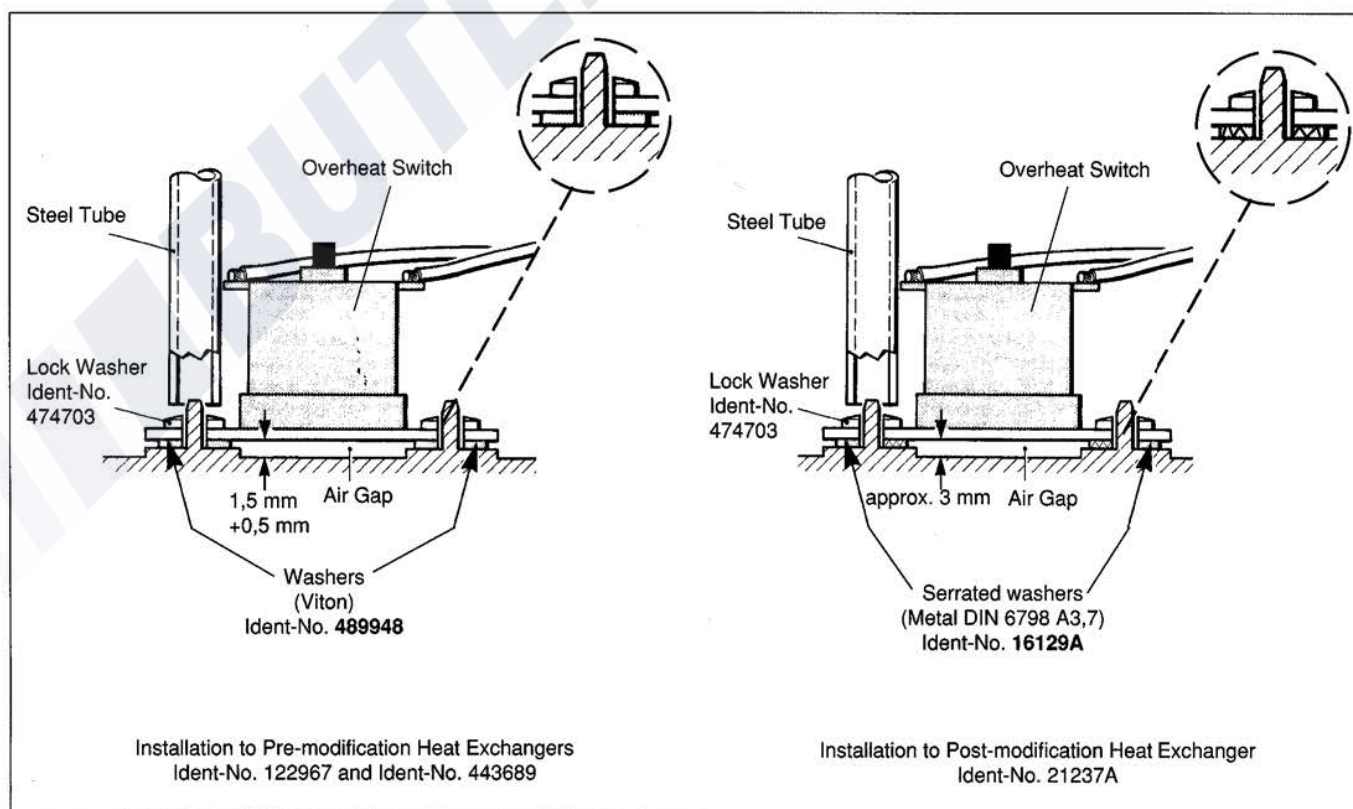

6 Components

It is therefore essential to identify the heat exchanger for
overheat switch installation (refer to Figure).

Caution!

- For installation of overheat switch on pre-modification heat exchangers (Ident-No. 122967 and 443689) use washers, Viton, (Ident-No. 489948) only (refer to Figure).
- For installation of overheat switch on modified heat exchangers (Ident-No. 21237A) use serrated washers, metal, (Ident-No. 16129A9) only (refer to Figure).
- For installation use one pair of washers.
- Old modification kit bags (Ident-No. 106050 and 465313) possibly in stock may only be used on the pre-modification heat exchanger (Ident-No. 122967 and 443689).

- Position new serrated or Viton washers on spigots.
- Locate overheat switch on spigots.
- Press on new lock washers (type B) e.g. with steel tube so that flange of overheat switch seats free from play on the raised cast lugs.
- Insert connector terminals into top of connector.
- Clip on top of connector.
- Screw safety switch to intermediate housing.
- Secure cable clamps to motor housing.
- Fit upper half housing shell and seal for connector terminals.
- Fit covers (cover with reflecting inner surface to outlet side).
- Connect flame detector.
- Fit cap (wiring harness) and screw on.
- Install heater and perform test run.

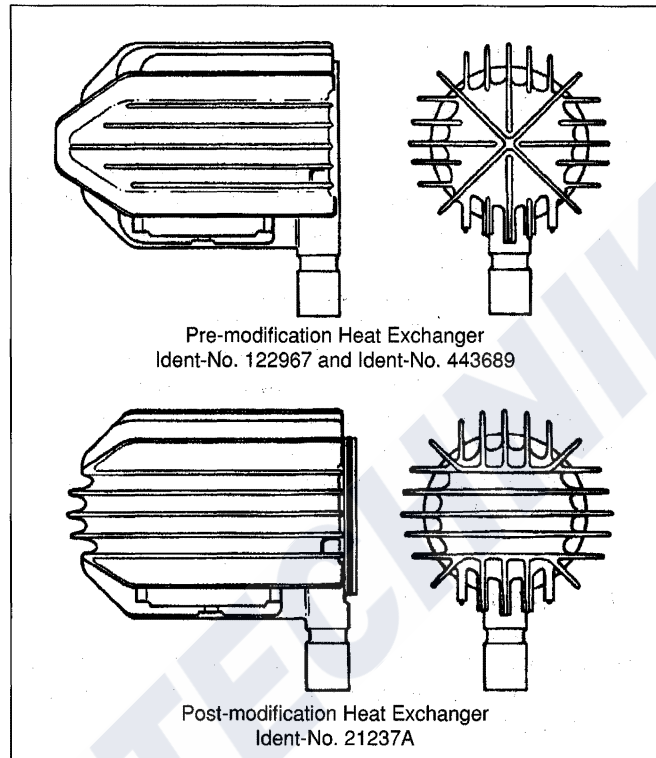

6.1.9 Heat Exchanger

Description: Within the heat exchanger the heat generated by combustion is transferred to the fresh air for heating.

Removal:

- Remove drive assembly (6.1.1)
- Remove glow plug or glow pin (6.1.5 or 6.1.6).
- Remove flame detector (6.1.7).
- Loosen 3 screws of fuel connection (Phillips screwdriver) and remove connection.
- Loosen 3 screws on heat exchanger housing (hexagon socket wrench) and remove heat exchanger.

Test/Repair: Clean contaminated components. Ensure that also the exhaust connection and return point (A) are cleaned. Before installation renew fleece (refer to 6.1.4) and clean burner tube (refer to 6.1.10).

Caution! In case not the same heat exchanger or the same housing is installed, observe repair instructions according to Chapter 7.3.1.

Installation: Proceed in reverse order of removal.

Caution: It is mandatory to replace gaskets and O-rings (use genuine spares). The three hexagon socket head screws are to be torque-tightened with $3.5 + 0.5 \text{ Nm}$.

Note: The exhaust system (flexible tube and exhaust silencer) have to be included in the cleaning, effort.

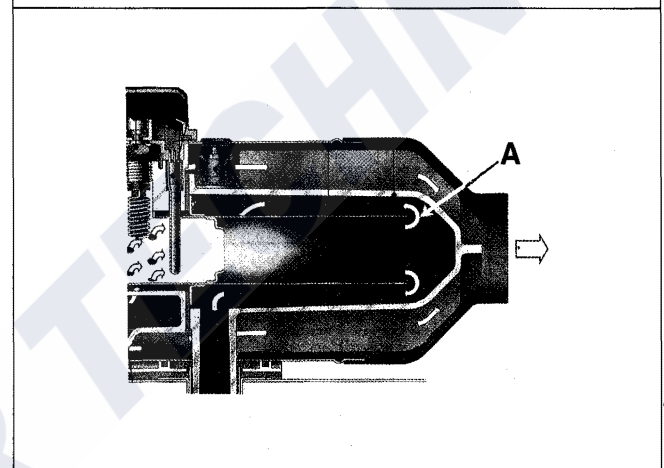
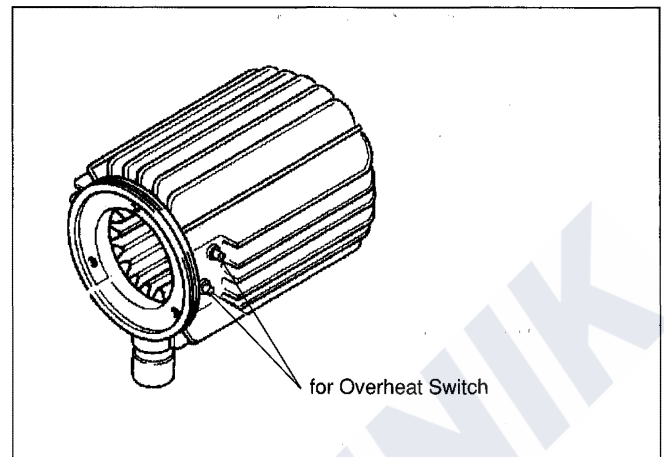

Test/Repair: Clean all contaminated components. In case of a thermal deformation of the tube or the fleece retaining ring ("A") the burner tube is to be replaced as a complete assembly.

Installation: Proceed in reverse order of removal. Replace fleece (refer to 6.1.4) and gasket between heat exchanger and housing. Torque: 3.5 Nm

6.1.10 Burner Tube

Description: In the burner tube the combustion of the fuel ignited by the glow plug (glow pin in Air Top units) takes place.

Removal:

- Remove covers (inlet and outlet) (Phillips screwdriver).
- Remove upper and lower housing half shells.
- Remove glow plug or glow pin and flame detector (refer to 6.1.5 to 6.1.7).
- Disconnect drive assembly (Phillips screwdriver).
- Loosen 3 screws on heat exchanger housing (hexagon socket wrench) and remove heat exchanger.
- Loosen 3 screws on burner tube housing (Phillips screwdriver) and remove burner tube.

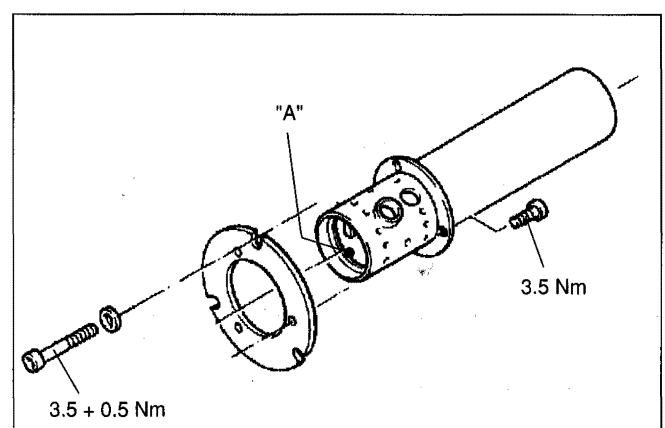

6 Components

6.2 Fuel System Components

6.2.1 Dosing Pump

Description: The dosing pump provides a controlled fuel supply for the heater and is also a fuel shut-off device. The pump operates on the magnetic piston pump principle.

Cycle Frequency in Operating Voltage Range:

	HL 18 B	HL 18 D	AirTop 18
FL	Hz 1.01	Hz 0.87	Hz 0.87
PL	—	Hz 0.52	Hz 0.52

Test: Internal Resistance

	HL 18 B/D	AirTop 18
12 V	Ω 10.1 \pm 5%	Ω 10.1 \pm 5%
24 V	Ω 40.4 \pm 5%	Ω 40.4 \pm 5%

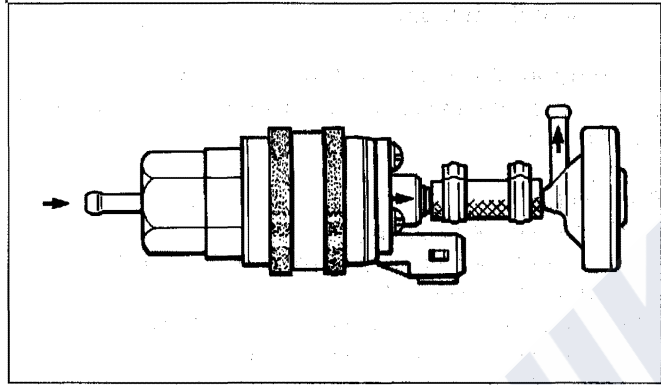

Removal/Installation: After disconnecting the electrical connections, hoses, hose clamps and the clamping ring the dosing pump may be removed. Installation is in reverse order.

The pump fuel delivery rate may be checked by means of a fuel quantity check.

- 1) Detach the fuel pipe from the heater and insert into a measuring cylinder or, where space is restricted, plug onto a graduated burette (capacity 100 ml).
- 2) Switch on heater.

Applicable to HL 18B/D with SG 1559 and SG 1561 GT). After 120 sec there will be an automatic switch-off upon failure with a subsequent repeat start. Applicable to AirTop 18B/D with control unit 24Volts, Order No. 241.89A.

After 115 sec there will be an automatic switch-off upon failure with a subsequent repeat start.

Independent of the type of control unit fuel is delivered for 90 sec during a start cycle. Start and repeat start correspond to 2 x 90 sec.

Repeat procedure, until fuel escapes.

Note: During measuring procedure check voltage at control unit.

SG 1559 contacts C1 (+) and C2 (-)
 SG 1561 GT contacts B1 (+) and B2 (-)
 SG Order No. 241.89A contacts C6 (+) and C1 (-)

- 3) For measurement switch heater on again and determine fuel volume increase over 2 x 90 sec. Switch-off is automatic.

- 4) For evaluation enter the data into the appropriate graph. The point of intersection must be within the shaded area.

Repair: A defective dosing pump must be replaced. After replacement the CO₂-value has to be measured and re-adjusted if required (refer to 6.1.3).

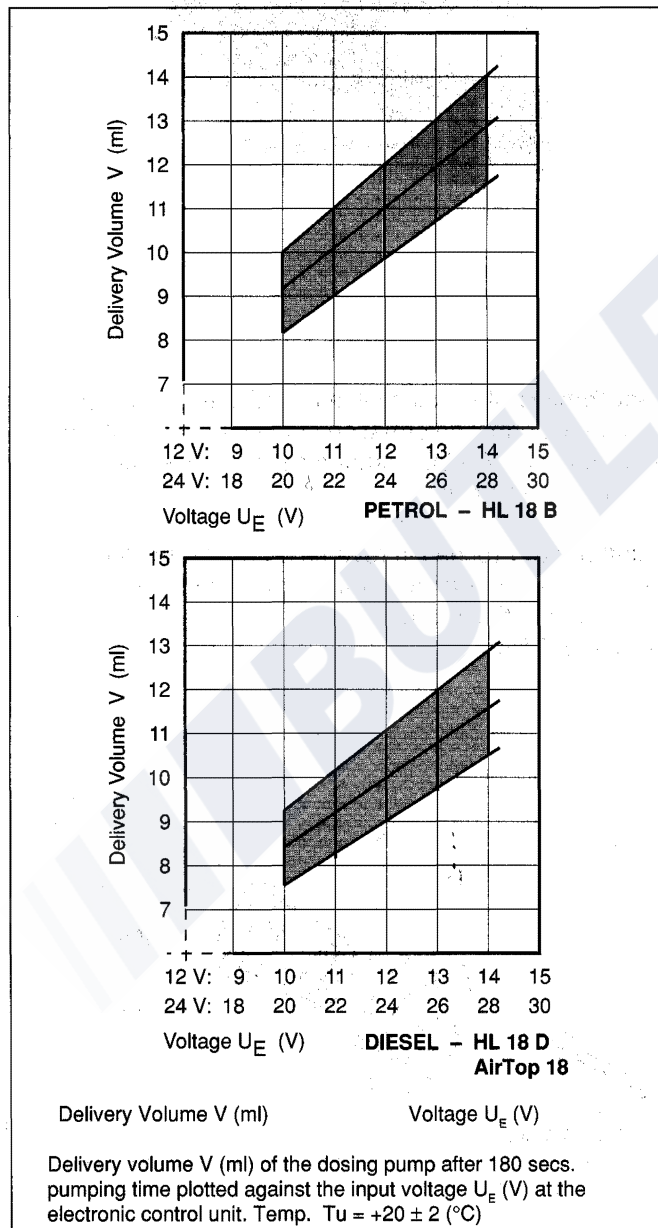

Note: If a priming pump is fitted, ensure that the delivery pressure does not exceed the maximum permissible pressure for the dosing pump input (refer to table).

Permissible fuel delivery height H (m)	at max. permissible overpressure (bar) in the fuel supply line
0,00	1,5
1,25	1,4
2,50	1,3
3,75	1,2
5,00	1,1
6,25	1,0
7,50	0,9
8,75	0,8
10,00	0,7
Permissible fuel suction height S (m)	at max. permissible overpressure (bar) in the fuel tank
0,00 (B + D)*	- 0,15 (B + D) *
0,50 (B + D) *	- 0,11 (B + D) *
1,00 (D) *	- 0,07 (D) *
* B = Petrol D = Diesel	

6.2.2 Fuel Tap

Description: The fuel tap is used for fuel extraction and bubble separation, therefore it must never be replaced by a regular T-union. The flow speed, which may be too high in standard T-unions, promotes the delivery of bubbles to the dosing pump.

Note: The fuel tank must be sufficiently ventilated (e.g. at filler cap).

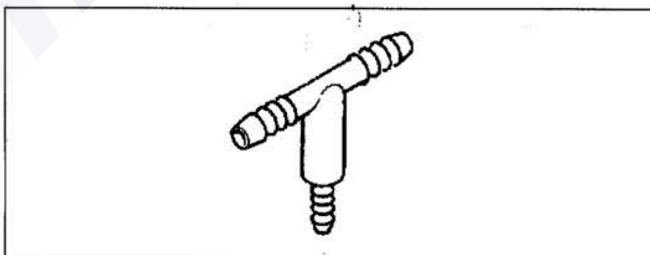

6.2.3 Fuel Filter

Description: The filter may be installed in the fuel suction line between tank and dosing pump. Should contaminated fuel be involved, the filter must be retrofitted.

Test: Replace contaminated filter (use only Webasto Filter, Ident-No. 487 171, refer to Installation Instructions and Spare Parts List).

Check filter housing and connections for leaks.

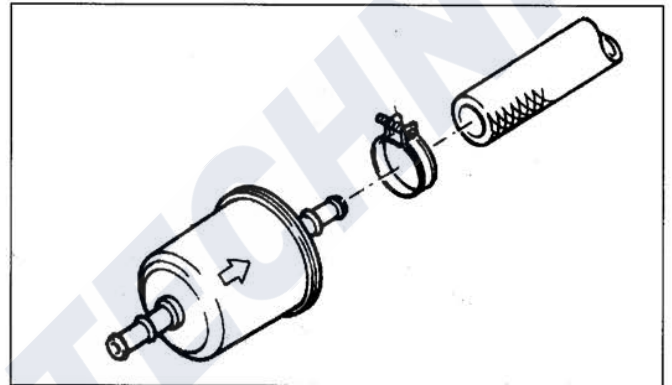

6.2.4 Fuel Tank Tap

Description: The fuel tank tap is used to extract fuel from the fuel tank. It has to be ensured, that the installation on the tank and the fuel line connection do not show any leaks.

The gap between the pipe end and the fuel tank floor is intended to prevent dirt and water from entering the pipe.

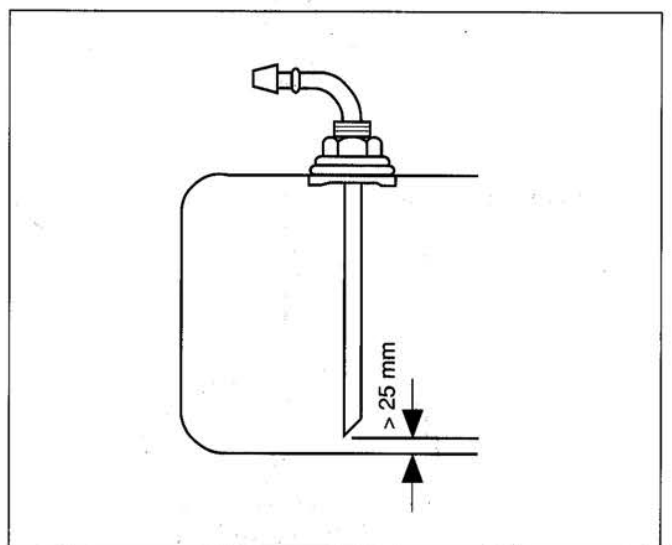

6 Components

Fuel Tap Da 5,5 mm 353 205
 Fuel Tap Da 8,0 mm 353 213

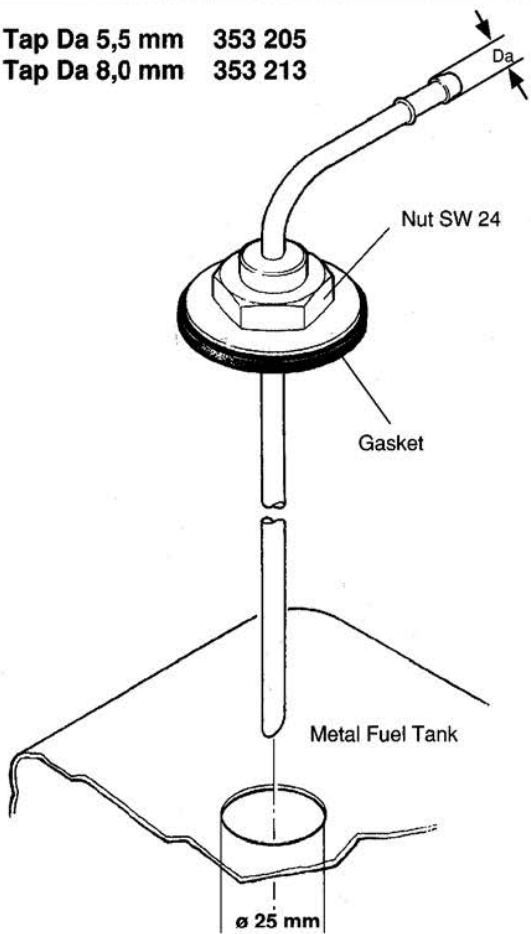

Fuel Tapping from Metal Tank with Tube Fuel Tap

Required parts for self-manufacture of fuel tap:

- 1 Banjo Bolt M14 x 1,5 DIN 7623 commercial standard
- 1 Ring Hose Coupling 14 x 5 DIN 7642 commercial standard
- 2 Copper Gaskets DIN 7601 commercial standard
- 1 Copper Tube dia. 8 mm; length 30 mm commercial standard

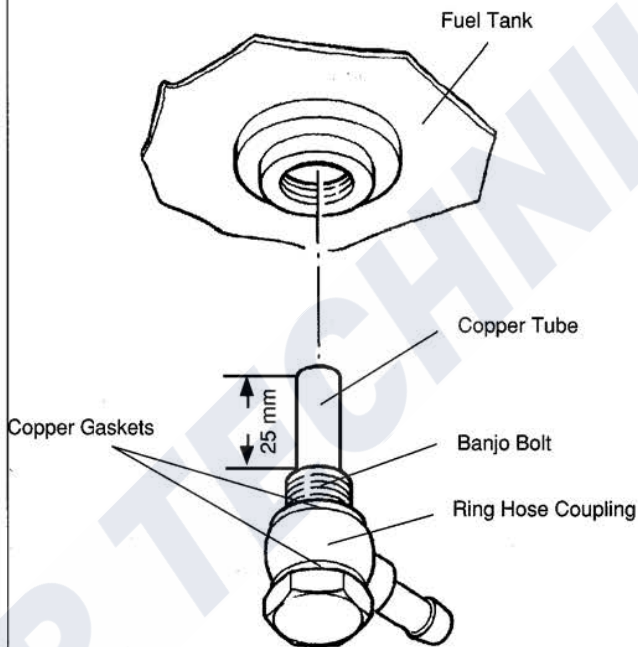

Fuel Tapping from Fuel Tank Drain

Fuel Tap 25908A

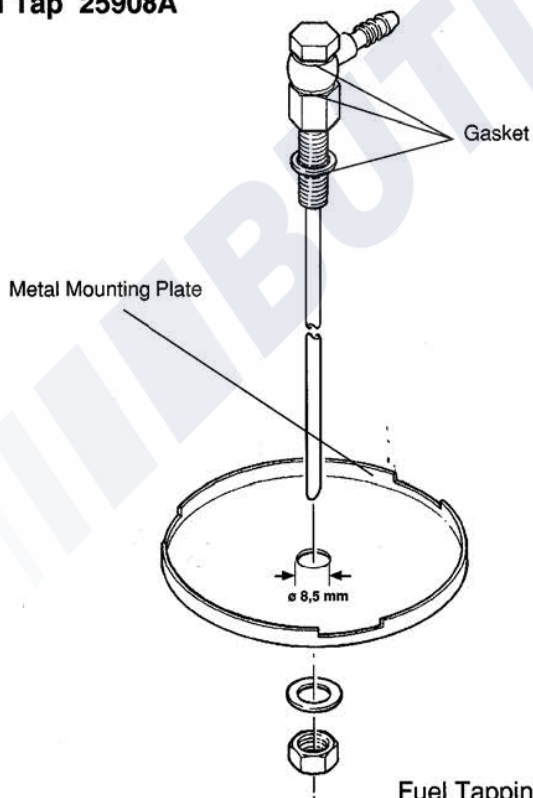

Fuel Tapping via Metal Mounting Plate

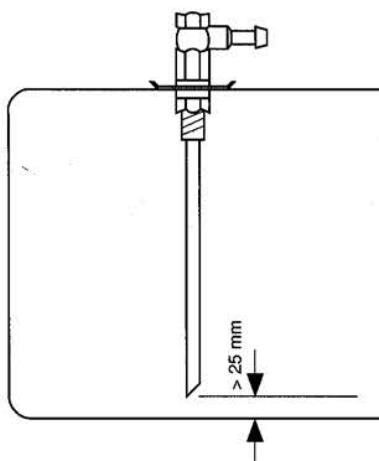

6.3 Exhaust and Combustion Air System Components

6.3.1 Pressure Balancer (Exhaust/Suction Feedthrough)

Description: The pressure balancer is a component for combustion air entry and exhaust exit and is connected to the relevant pipes. The pressure balancer prevents a "blow-out" of the flame in the heater and pressure differentials between combustion air inlet and exhaust outlet.

Note: As a rule the pressure balancer is required only for heater with part-load operation. In boats and ships the installation is mandatory. In the area of the ship outer wall an insulation plate made of V2A-steel has to be inserted.

Test: Remove internal and external contaminations from pressure balancer. Check for obstructions. Check hose connections for secure fit.

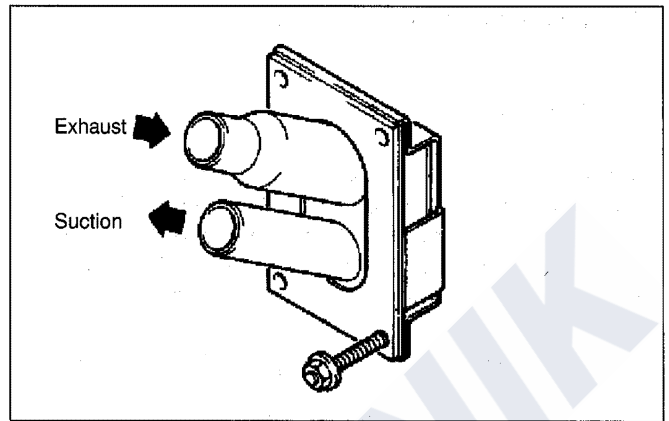

Note: For boats and ships only an insulation of the exhaust pipe using an insulation tape (Ident-No. 428 132, yardware or 443 247, roll of 25 m) is permissible. The insulation must be applied in three layers at least.

An alternative insulation may be applied using a heat protective hose (flexible pipe; D, 28,0; Ident-No. 215 43A) (refer to Accessories Catalogue).

6.3.2 Exhaust Silencer

Test: Check for obstructions and check CO₂-value as required.

The exhaust silencer is to be replaced in case of heavily contaminated heat exchanger of flexible exhaust pipe.

Note: For boats and ships only an insulation of the exhaust silencer using an insulation tape (Ident-No. 428 132, yardware or 443 247, roll of 25 m) is permissible. The insulation must be applied in three layers at least.

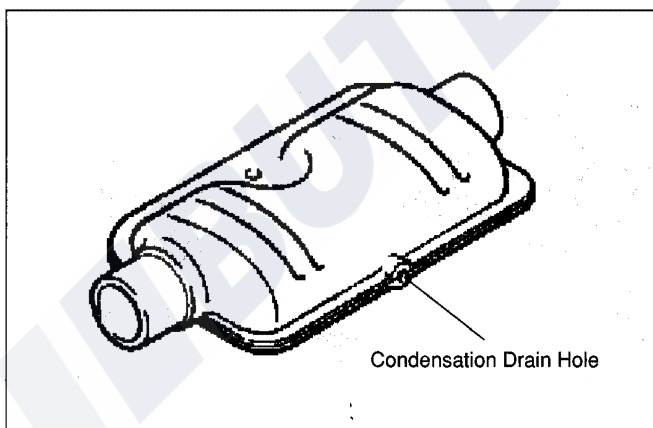

6.3.4 Combustion Air Pipe

Test: Check for obstructions. The opening is not to point upwards in order to prevent the ingress of water.

Note: Observe maximum pipe lengths according to Installation Instructions.

The combustion air tap should be located in an area free from dust.

In cases of extremely high dust concentrations, the combustion air filter (Ident-No. 219 62A, refer to Accessories Catalogue) has to be used. Filter replacement and cleaning according to the manufacturer's instructions.

6.3.3 Flexible Exhaust Pipe

Test: Check for contamination, damage, and reduced cross-section (e.g. accumulation of condensation, bends). The maximum drill lengths according to the Installation Instructions have to be observed.

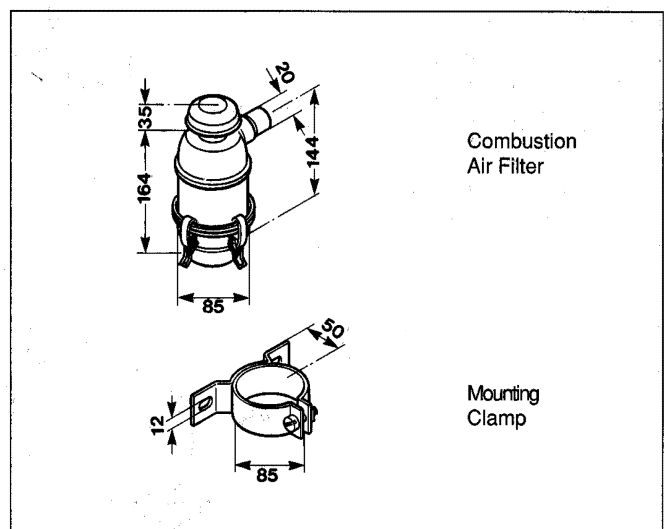

6 Components

6.4 Electrical System Components

6.4.1 Control Unit

Description: Upon switch-on, the control unit performs the complete functional control of the heater (refer to 5. "Description of Operation") by evaluating the signals of the flame detector and the full-load/part-load functions of the room thermostat and the change-over switch.

The heaters may be operated with different control units:

SG 1559	for HL 18B/D
SG 1561 GT	for HL 18 B/D
Order No. 241.89A	for Air Top 18/B/D and TRS
(SG 1561 GS)	

For the TRS equipment with SG 1559 and SG 1561 GT the control unit SG 1547 TRS is required additionally.

The following Figures give an overview of the use of the control units 12 V and 24 V with the possibilities for combination with pulsing glow relays and dropping resistors for the glow plug. The conversion of SG 1559 to SG 1561 GT (integral glow pulsing) is described in Chapter 8.

Test: A test of the control units SG 1559 and SG 1561 GT is only possible with the Webasto test unit (refer to 7.2.2).

Removal/Installation: The control unit is to be installed in a protected location with its connections pointing downwards (also refer to 1.1, 7.1.2 and Installation Instructions).

Repair: A defective control unit has to be replaced as a complete unit.

Note: Components like e.g. the control unit, pulsing glow relay, and part-load resistor for 12 V are marked for identification with red letters, the control units for 24 V with green letters.

12-Volt-Units

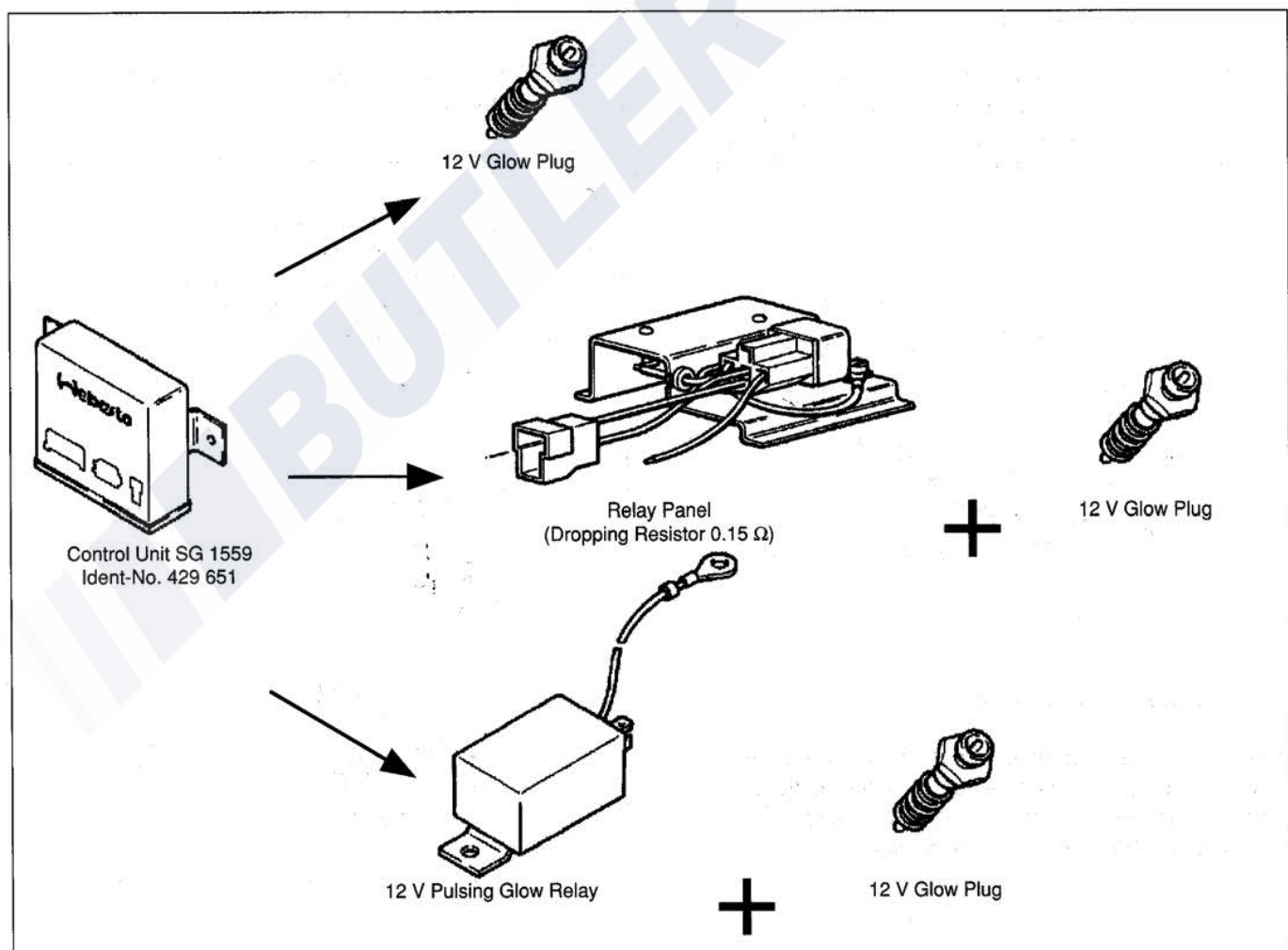

12-Volt-Units

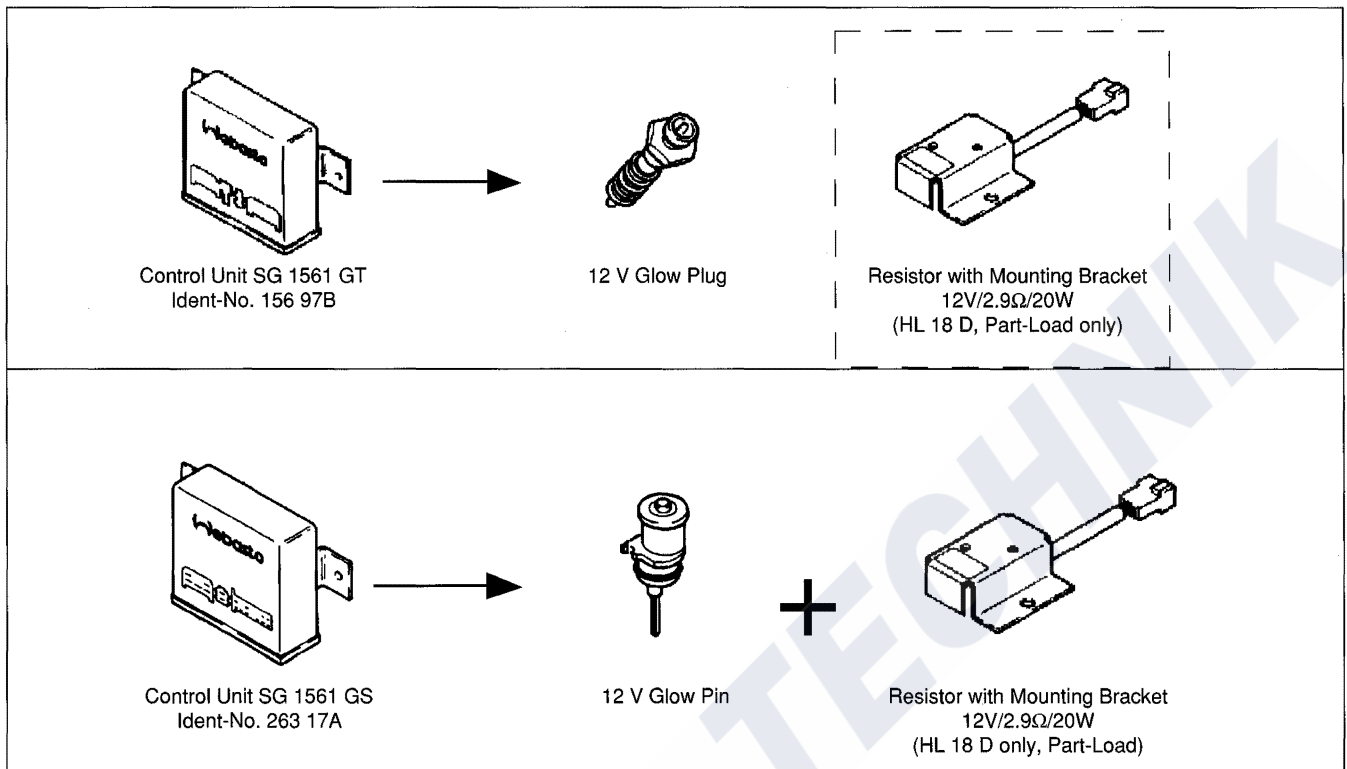

24-Volt-Units

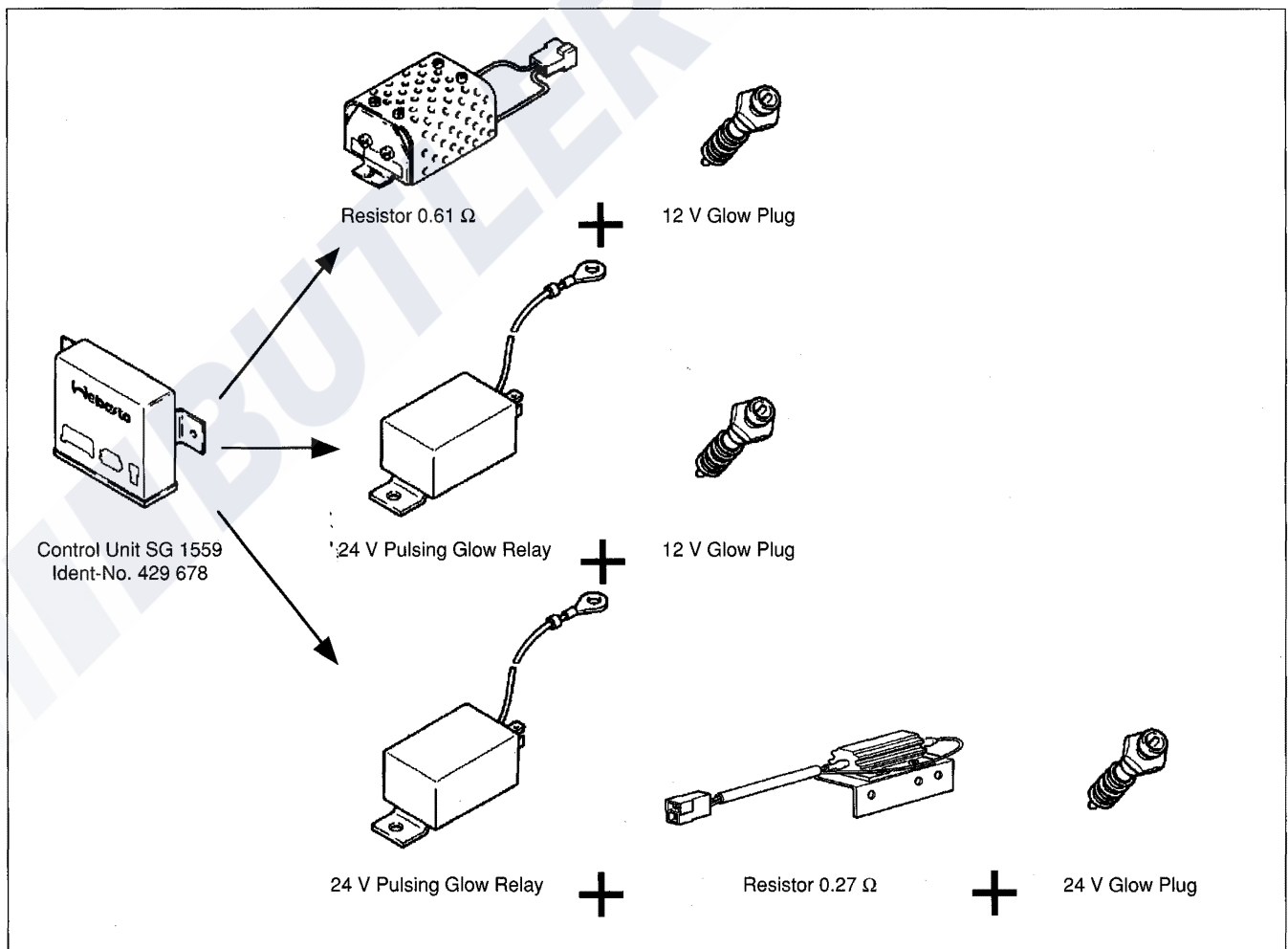

6 Components

24-Volt-Units

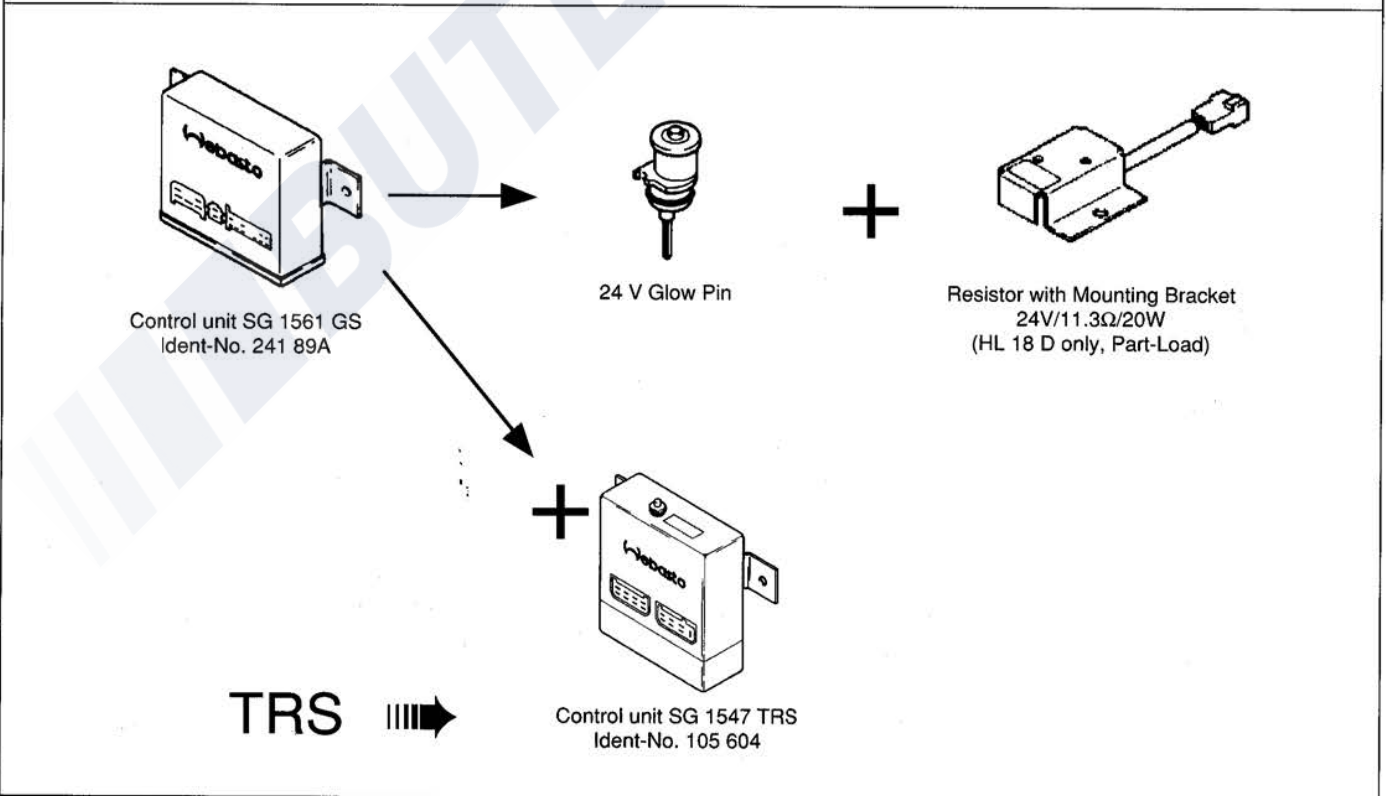
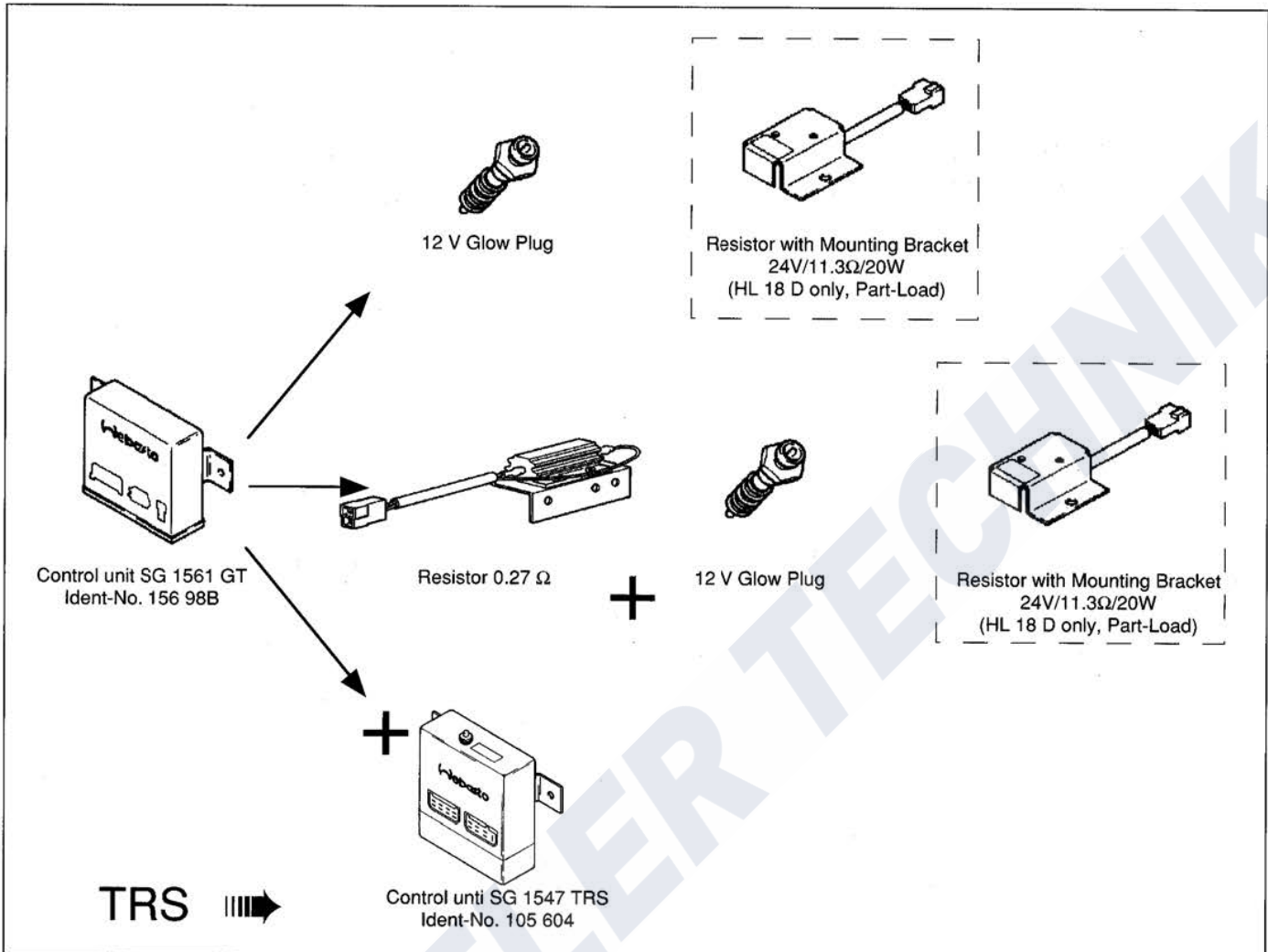

6.4.2 Wiring Harness

Description/Installation: According to the control unit in use the appropriate wiring harness (refer to Figure) is installed.

Control Unit SG 1559: For the heaters HL 18 D (Diesel) the standard wiring harness is used without modifications. For the heaters HL 18 B (Petrol) the brown wire (br) must be removed from socket A No. 8 (refer to 9. "Circuit Diagram").

For 24 Volt heaters the wire bridge must be removed from the yellow wire (ge) and replaced with a 0.61 Ω resistor.

Coverctions from SG 1559 to SG 1561 GT (integral glow pulsing) retaining the wiring harness installed are described in Chapter 7.

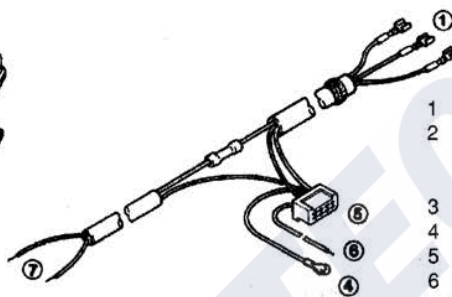
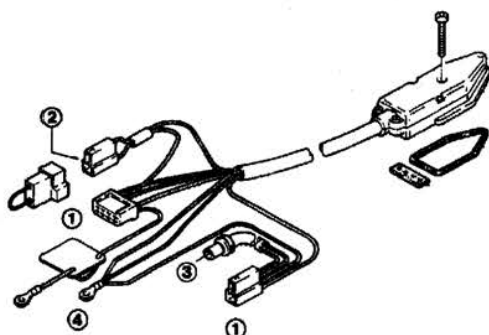

- 1 Control Unit
- 2 for 12 V: Wire Bridge or Pulsing Glow Relay
for 24 V: Dropping Resistor or Pulsing Glow Relay
- 3 Dosing Pump
- 4 Ground
- 5 Digital Timer
- 6 Vehicle Illumination Terminal 58
- 7 Fuse Holder

Wiring Harness for Control Unit SG 1559

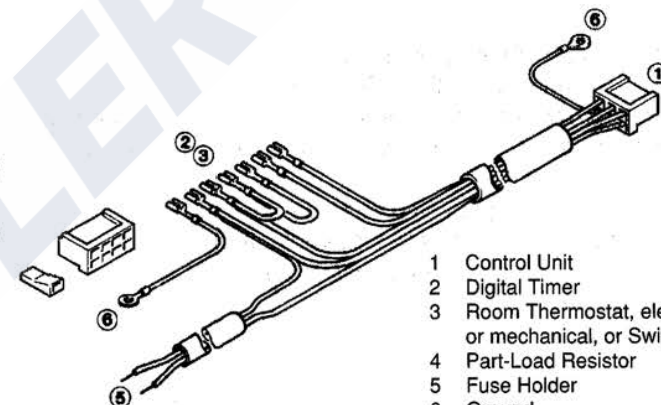
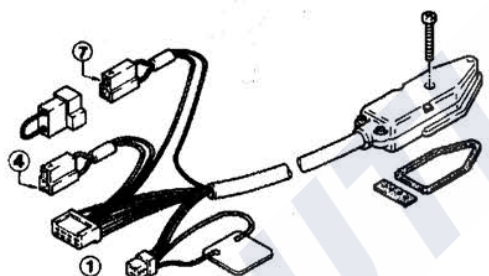

- 1 Control Unit
- 2 Digital Timer
- 3 Room Thermostat, electronic or mechanical, or Switch
- 4 Part-Load Resistor
- 5 Fuse Holder
- 6 Ground
- 7 for 12 V: Wire Bridge
for 24 V: Dropping Resistor for 24 V Glow Plug

Wiring Harness for Control Unit SG 1561 GT

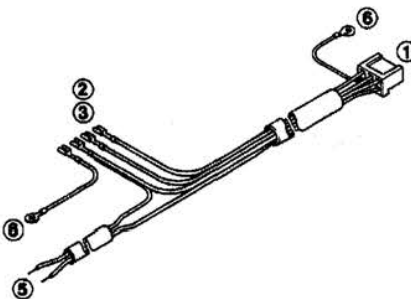
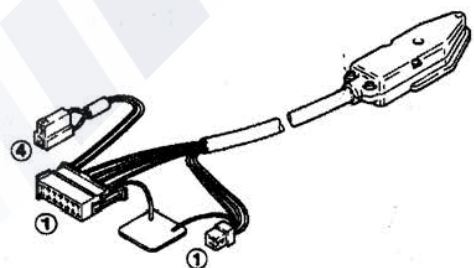

- 1 Control Unit
- 2 Digital Timer
- 3 Room Thermostat, electronic or mechanical, or Switch
- 4 Part-Load Resistor
- 5 Fuse Holder
- 6 Ground

Wiring Harness for Control Unit SG 1561 GS

6 Components

6.4.3 Glow Plug Dropping Resistor 0.61 Ω (Option)

Description: 24 Volt heaters without glow pulsing require a dropping resistor with 0.61 Ω when using a 12 V glow plug.

Adjustment: Remove perforated cover. Loosen screw of adjustable collar and slide collar.

Note: The dropping resistor may be substituted with a pulsing glow relay and a 24 V glow plug.

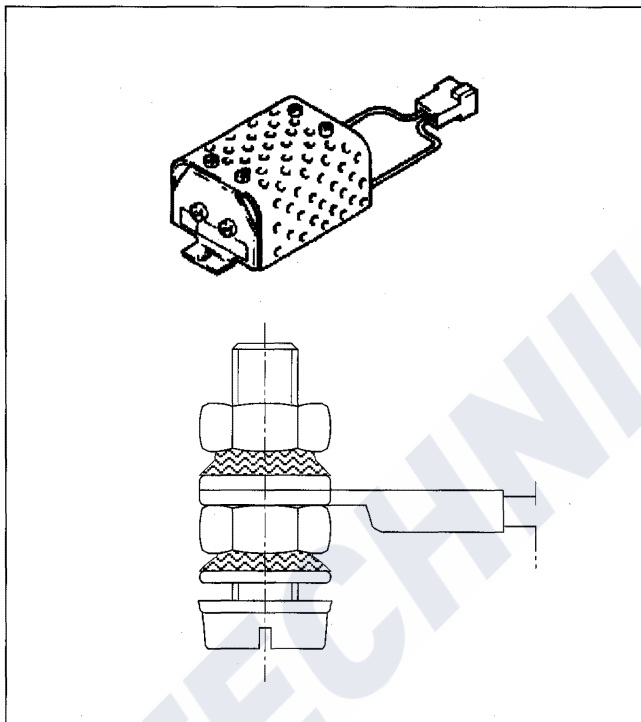

6.4.4 Glow Plug Dropping Resistor 0.27 Ω (Option)

Description: The dropping resistor reduces the temperature of the filament to increase the 24 V glow plug life.

CAUTION: The temperature of the resistor might increase up to 160 °C. During installation it has to be observed, that there is proper ventilation and that no flammable and temperature-sensitive components are in its vicinity.

For heat dissipation, the mounting bracket must be secured directly to metal. Should this not be possible, the appropriate condition has to be provided by using heat-conducting distance pieces.

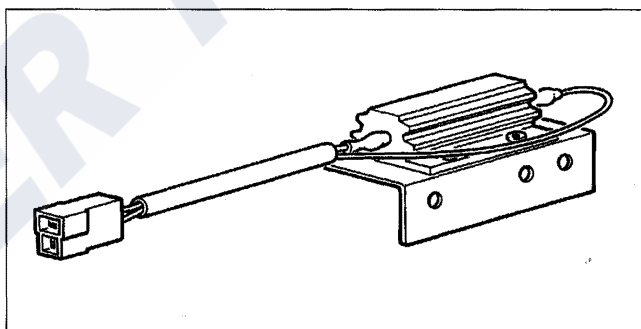

6.4.5 Resistor (Part-Load)

Description: The resistor reduces the motor speed in the part-load operation.

Test:

	HL 18 B/D	AirTop 18 B/D
12 V	2.9 Ω	2.9 Ω
24 V	11.3 Ω	11.3 Ω

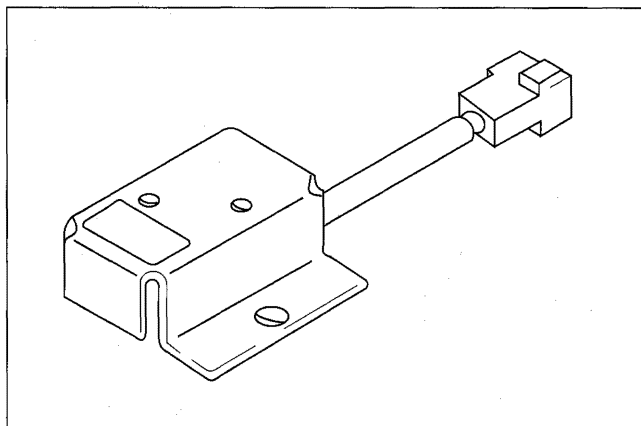

6.4.6 Pulsing Glow Relay (Option)

Description: The pulsing glow relay protects the glow plug from overload. At a 0.8 Hz cycle rate with switch-on pulses of different length in time, the power supply is maintained constant in the voltage range from 11.5 - 14 V (23 - 28 V).

Electrical Connection:
(Conversion/Retrofit)

- Check of the two-pole connection for the pulsing glow relay.
- Wires with colours ge and ws: no check.
- Wires 2 x yellow: check for continuity, replace wire as required and re-check.
- For connection refer to Figure.

NOTE: The brown ground wire is to be connected to the battery minus in installations with battery switch.

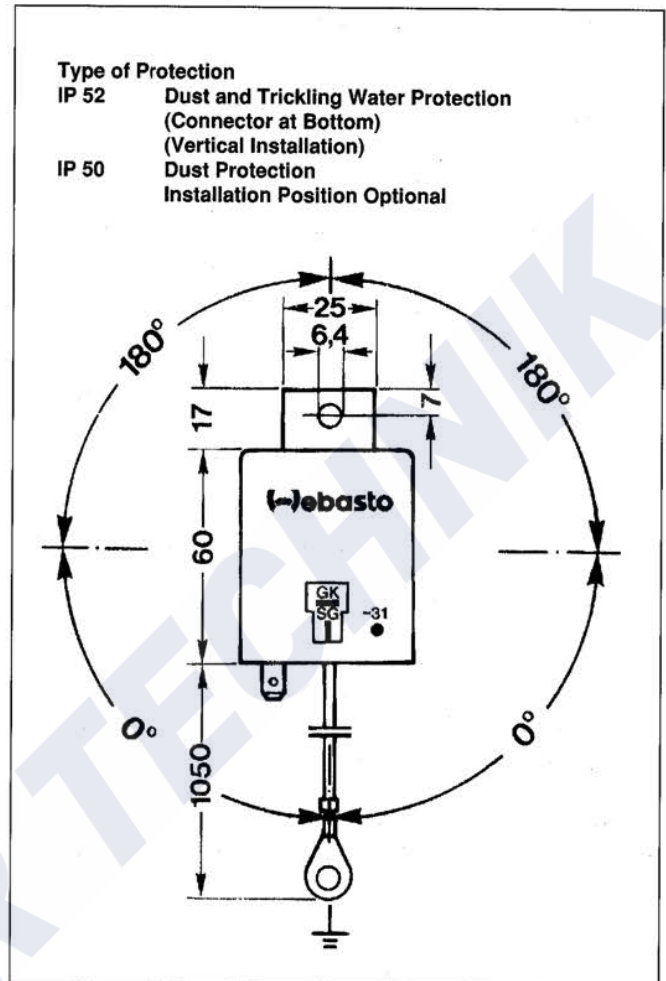

7 Repair and Disassembly Instructions

7.1 General Important Notes for Repairs

7.1.1 Removal and Installation of Heater

Prior to performing any work on the heater, the power cable of the vehicle battery supply must be disconnected. As long as the heater is in operation, the **main supply from the battery must not be disconnected** to prevent the **danger of overheating the heater** with an associated response of the overheat switch.

When performing extensive heater repair, a complete removal is advisable. The heater can be removed by loosening its retaining clamp. Prior to removal the fuel line has to be disconnected from the fuel connector. The fuel connector must be plugged for sealing. The support thus remains fully installed in the vehicle.

Caution: When assembling the heater it is mandatory to renew all gaskets.

The **three gaskets** (combustion air inlet and exhaust outlet) must be renewed prior to every installation. Should it be required to remove the heater support, the gasket below the support also has to be replaced. This gasket will compensate for grooves up to a depth of max. 4 mm or ridges up to 2 mm in height.

When performing repairs, which result in a modification of the installation, the Installation Instructions for the heater have to be observed.

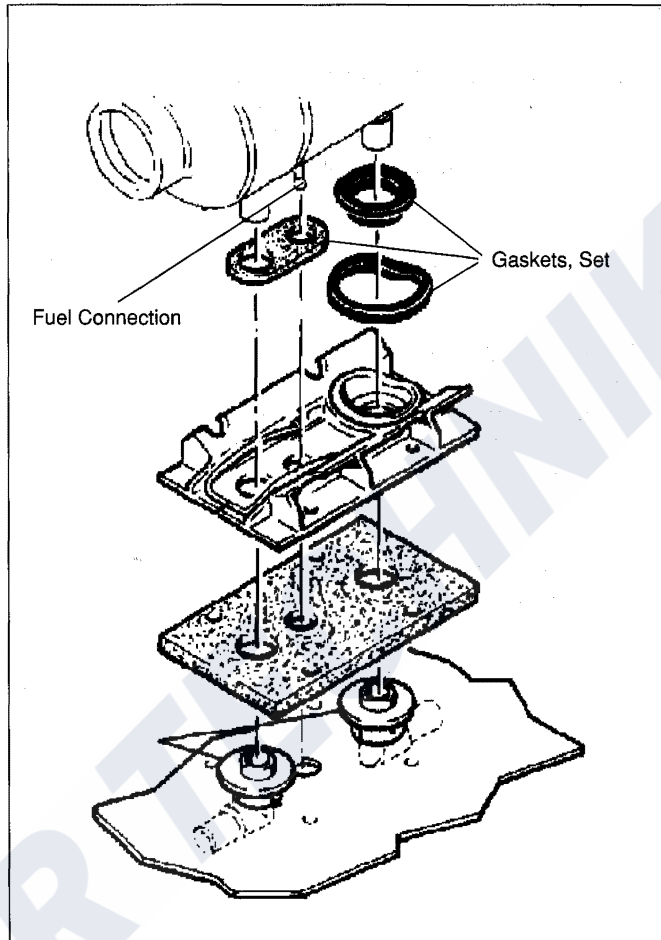

7.1.2 Work on the Vehicle

In the vicinity of the heater a temperature of 85 °C (storage temperature) must not be exceeded (e.g. during paint work on the vehicle).

7.1.3 Heater Test Run

The heater must not be operated - this also applies to preset timing operation - in closed areas like garages and repair shops without an exhaust venting system.

Operate heater for approx. 5 min., measure CO₂ value and adjust when out of tolerance.

7 Repair and Disassembly Instructions

7.2 Tools and Test Equipment

7.2.1 Hose Clamp

Description: As an assembly aid for the upper and lower housing half shells of the inlet and outlet cover a hose clamp with a clamp diameter $D_i = 120$ mm (Webasto Order No. 139.653) may be used.

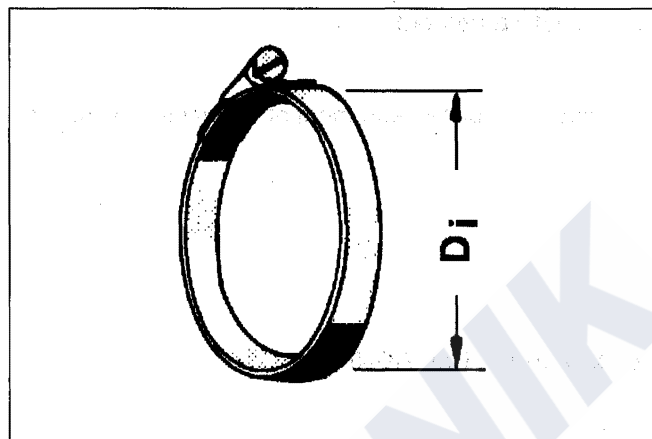

7.2.2 Test Unit

Description: The test unit is suitable for:

- a) complete test of heaters HL 18 B and HL 18 D, 12 and 24 Volts, in the vehicle
- b) separate test of control unit, 12 and 24 Volts, in the vehicle

Test Unit (Bag): 250 95A

Test Unit: 157 49A

Adapter Cable Harness for HL 18 with SG 1559
250 96A

Adapter Cable Harness for HL 18 with SG 1561 GT:
250 97A

- c) For control unit SG 1561 GS no test unit is available.

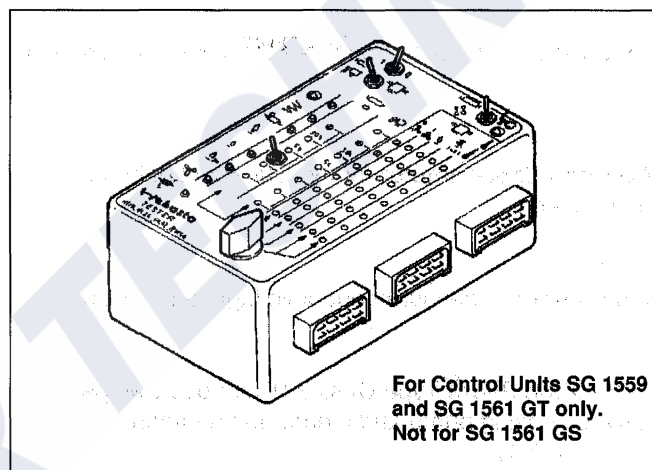

For Control Units SG 1559
and SG 1561 GT only.
Not for SG 1561 GS

7.2.3 Glow Plug Wrench

Description: Pipe spanner SW19 (standard) or wrench socket, extra long (19 mm / 1/2") and torque wrench (0.5 to 50 Nm).

7 Repair and Disassembly Instructions

7.2.4 Test Equipment

Supply Sources, e.g.:

CO₂ Indicator for measurement of CO₂ value in exhaust:

H. Maihak AG
Semperstr. 26–38
D-2000 Hamburg 39

Hans G. Werner & Co.
Postfach 28 67
D-7000 Stuttgart 1

Bruno Ihrig
D-6054 Rodgau 2
Dudenhofen

CO₂ Measuring Unit AD50

S + G Schmitt Meßgerätebau GmbH
Rheinhorststr. 14
D-6700 Ludwigshafen
Tel.: 06 21 / 67 40 87

Soot Meter for measurement of soot number of exhaust air:

Hans G. Werner & Co.
Postfach 28 67
D-7000 Stuttgart 1

Vibration Speedometer for measurement of heater motor speed:

Dr. E. Horn GmbH
Postfach 40
D-7036 Schönaich

Multimeter for measurement of voltage and current:

Standard

Installation Pliers Type CLIC 201 for hose clamps between dosing pump and membrane dampener (refer to 6.2.1):

Webasto,
Order No. 104 602 straight
Order No. 104 606 bent

Adapter Cable Harness for CO₂ adjustment

Webasto, Order No. 489 913

7.3. Performing Modifications

7.3.1 Conversion to a Modified Heat Exchanger with Housing

Description: For air heaters HL 18 D and HL 18 B a modified heat exchanger with modified housing has been introduced from the following serial numbers and up:

HL 18 D 12V Serial No. 117 203 and up

HL 18 D 24V Serial No. 127 150 and up

HL 18 B 12V Serial No. 157 701 and up

The combustion air pipe, its gasket, and mounting are not affected by this modification. The gasket of the combustion air pipe must however be included in the replacement. In order not to change the overheat switch response characteristics by the different heat transition, the switch is secured with two serrated lock washers (the old washers have to be discarded) (refer to 6.1.8).

Warning! Not observing the following safety precautions will result in a leakage on the heater with exhaust fumes escaping; this provokes the danger of an explosion or poisoning.

Only the following **modification kit HL 18 WÜ/Housing, Order No. 204 58A**, may be used and must be completely installed. Any type of combination of the new modification kit with previously used components, seals, etc. is not permissible.

The modification kit consists of:

- Heat Exchanger
- Housing
- O-Ring
- Seal
- 2 Serrated Lock Washers (for overheat switch)
- 2 Lock Washers (for overheat switch)

7 Repair and Disassembly Instructions

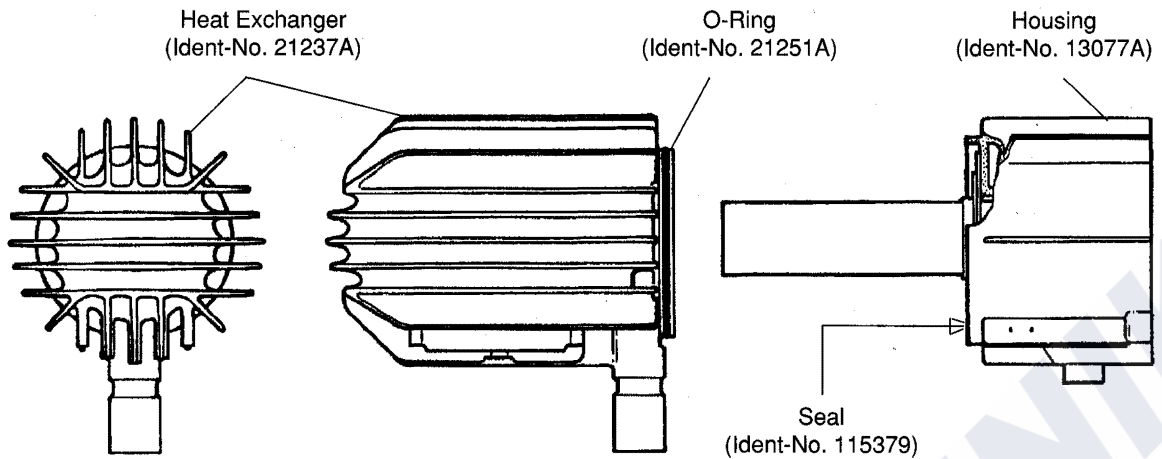

Modified Heat Exchanger with Housing

The modified heat exchanger can be identified as compared with the previous model by the following features:

Ident No. 21237A (up to now: 122967)
modified rib arrangement (refer to (A))
sealing surface projecting from housing (refer to (B))

Warning: The modified heat exchanger shall be used only as a complete set together with the modified housing and the O-Ring. Any type of combination of pre-modification components with new components is not permitted. Otherwise there will be a leakage on the heater with exhaust fumes escaping; this provokes the danger of an explosion or poisoning.

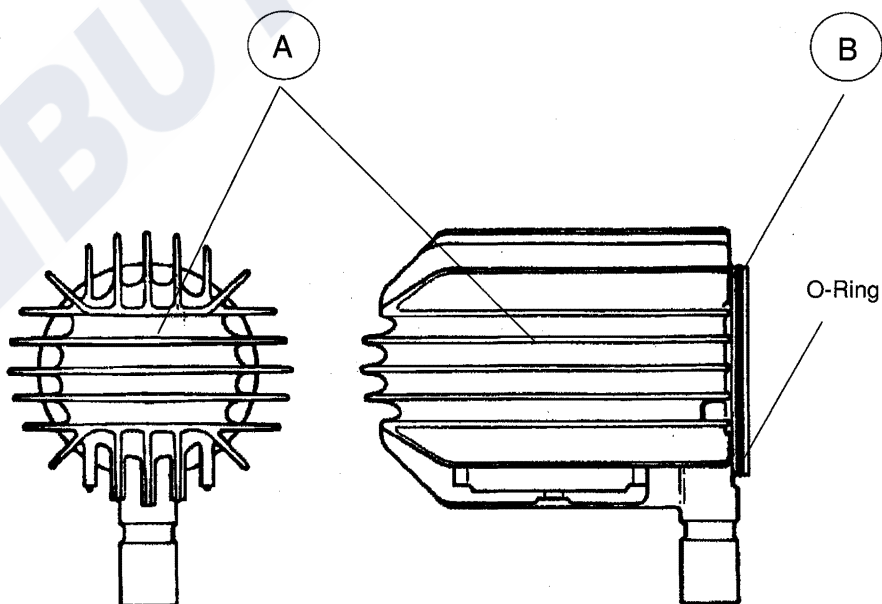

Modified Heat Exchanger

7 Repair and Disassembly Instructions

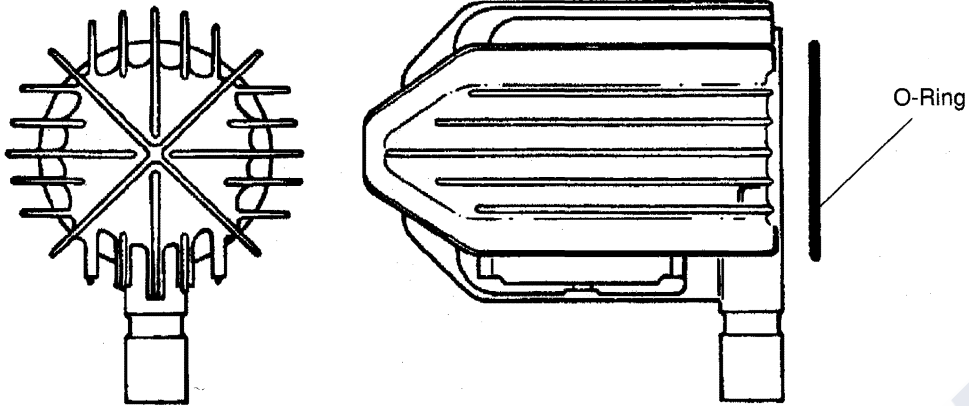

Pre-modification Heat Exchanger

The modified housing differs from the pre-modification model as follows:

Ident No. 13077A (up to now: 130770)
low location of sealing surface (refer to (C))

Warning: The modified housing shall be used only as a complete set together with the O-Ring and the modified heat exchanger. Any type of combination of pre-modification components with new components is not permitted. Otherwise there will be a leakage on the heater with exhaust fumes escaping; this provokes the danger of an explosion or poisoning.

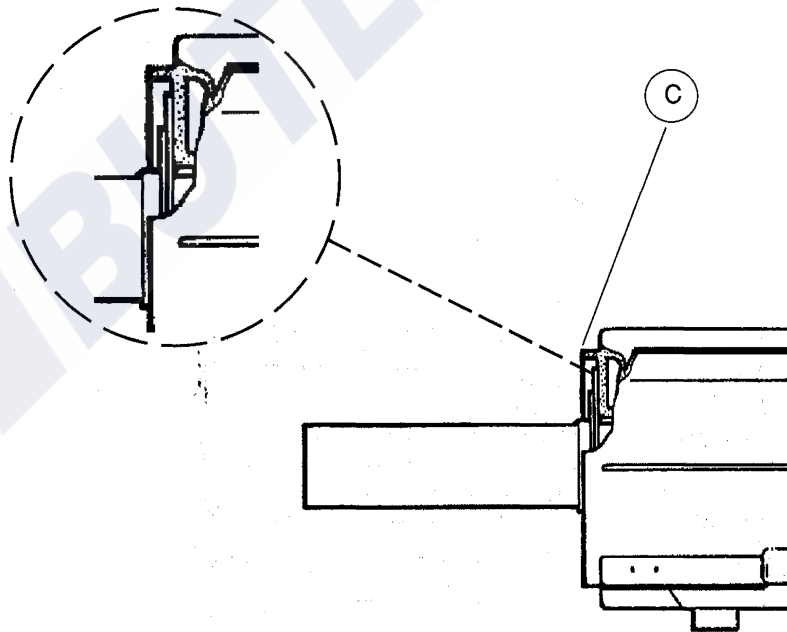

Modified Housing

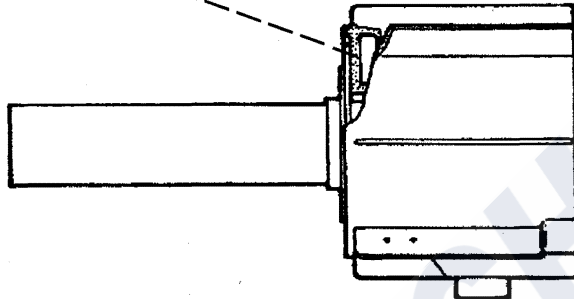
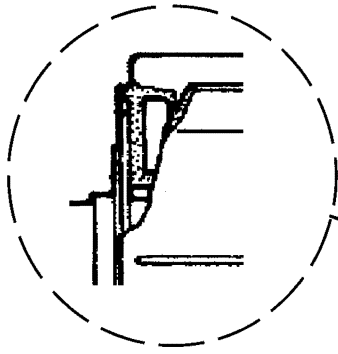

Pre-modification Housing

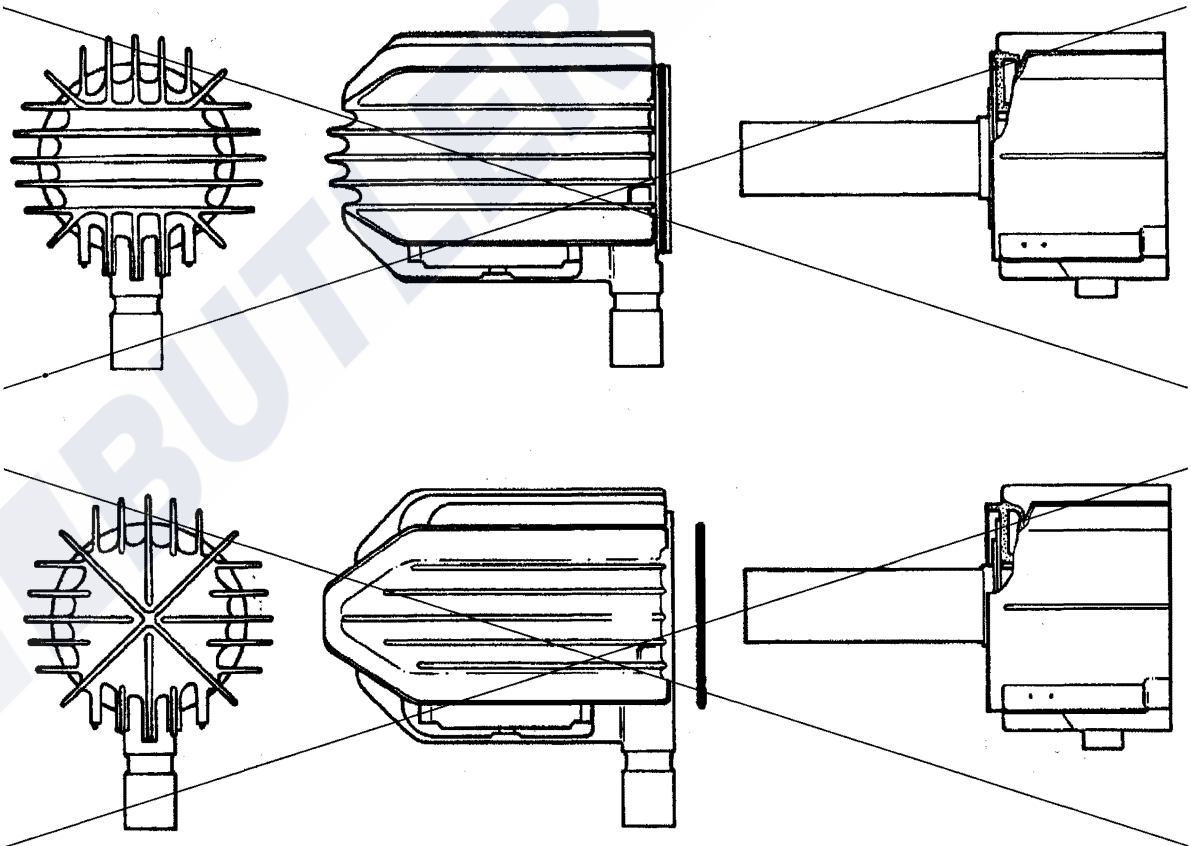

Component Combinations not permitted

7 Repair and Disassembly Instructions

7.3.2 Conversion of Control Unit SG 1559 to Control Unit SG 1561 GT with Integral Glow Pulsing

Description: The control unit SG 1561 GT is able to substitute the previously used control unit 1559, if glow plug dropping resistors, external pulsing glow relays, and glow plugs are replaced according to the following information:

Caution! Removal of the glow plug dropping resistor (24 Volt type) requires a replacement of the glow plug 12V against a glow plug 24V.

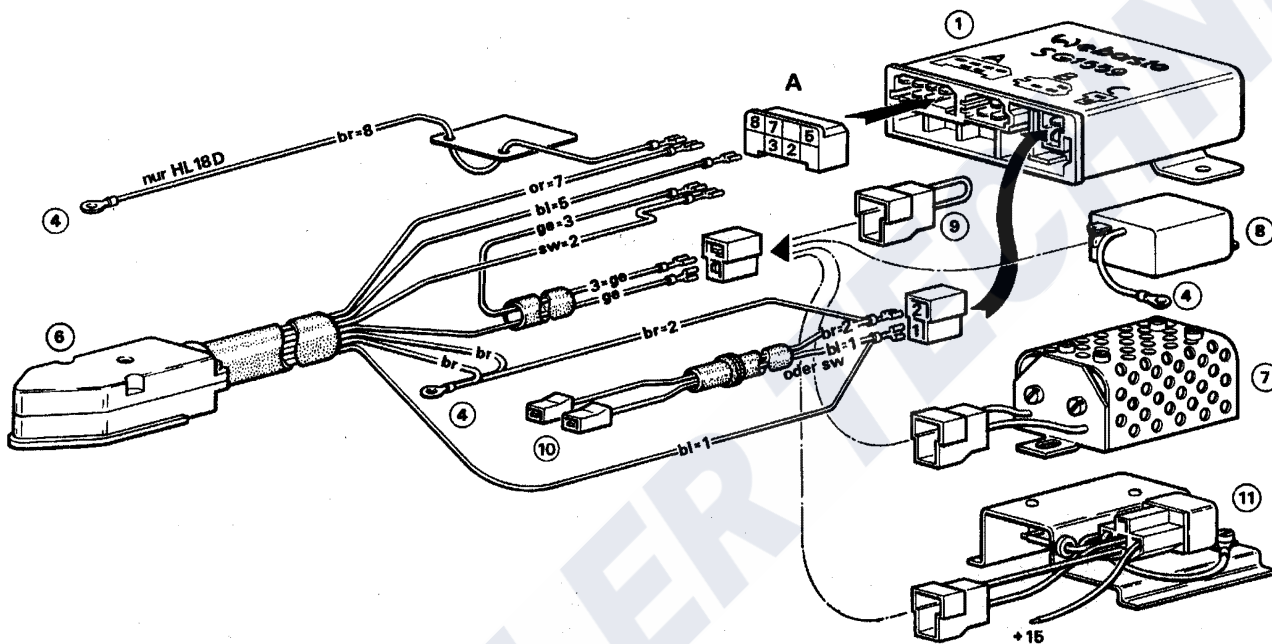

- ① Control Unit 1559
- ④ Ground
- ⑥ Cap, Heater
- ⑦ Glow Plug Dropping Resistor (24V) or
- ⑧ Pulsing Glow Relay (12V or 24V)
- ⑨ Bridge (for 12V)
- ⑩ to Dosing Pump
- ⑪ Relay Panel (12V)

⑦, ⑧, ⑨ and ⑪ are possible installation variants

Before Conversion

Wiring Harness Connection: Heater to Control Unit 1559, with possible Installation Variants

Conversion

For conversion of control unit 1559 to control unit 1561 GT with integral glow pulsing the connector terminals must be removed from the 8-pole connector and inserted again according to the Table and Figure.

Note: On HL 18 D only, terminal contact of wire (brown) is connected to new socket "C" according to Figure.

The table is also applicable for conversion of self-production wiring harnesses.

From connector Contact	Wire Gauge *	To connector (D) Contact
A2	0.75 mm ²	D1
A3	2.5 mm ²	D4
A5	0.75 mm ²	D3
A7	0.75 mm ²	D6
A8 (Diesel only)	0.75 mm ²	C1

* Up to a wire length of max. 7.5 m

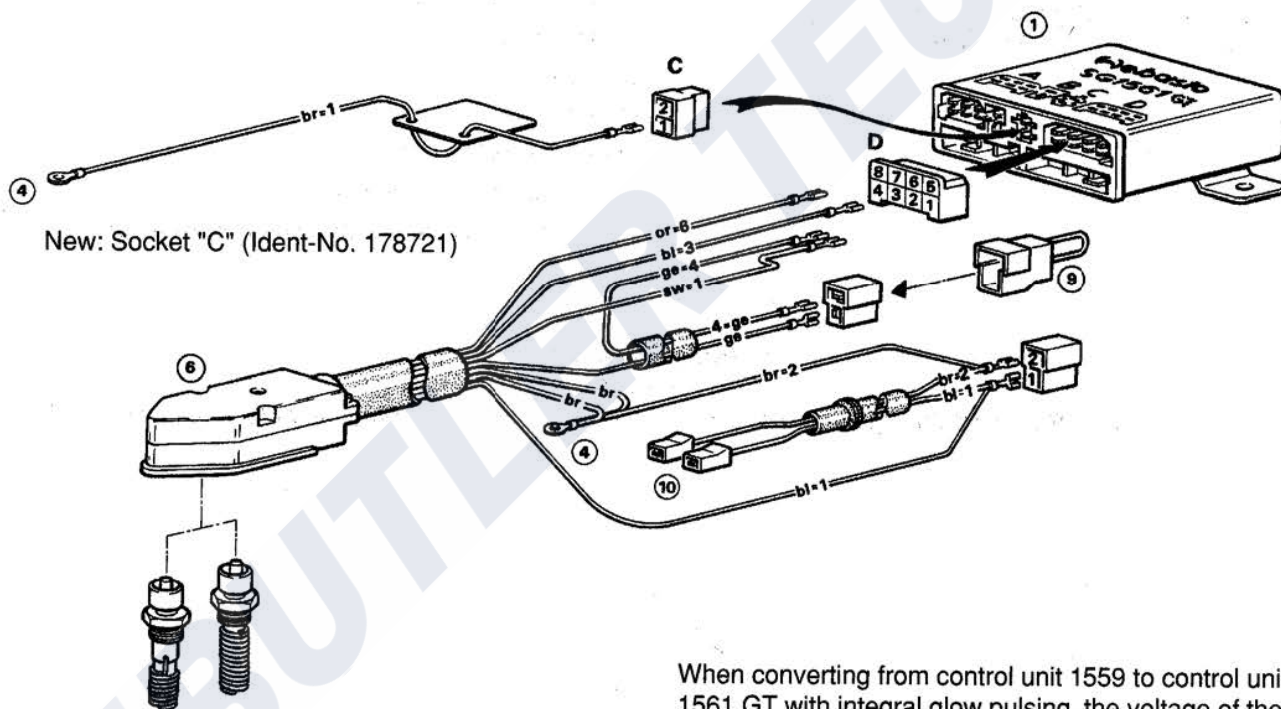

New: Socket "C" (Ident-No. 178721)

- ① Control Unit 1561 GT
- ④ Ground
- ⑥ Cap, Heater
- ⑨ Bridge (instead of pulsing glow relay, glow plug dropping resistor, or relay panel)
- ⑩ to Dosing Pump

When converting from control unit 1559 to control unit 1561 GT with integral glow pulsing, the voltage of the glow plug must be identical with the voltage of the control unit (refer to Para. 6.1.5).

- Heater/Control Unit 12V = Glow Plug 12V (Ident-No. 479594)
- Heater/Control Unit 24V = Glow Plug 24V (Ident-No. 157915)

After Conversion

Wiring Harness Connection: Heater to Control Unit 1561 GT with Integral Glow Pulsing

7 Repair and Disassembly Instructions

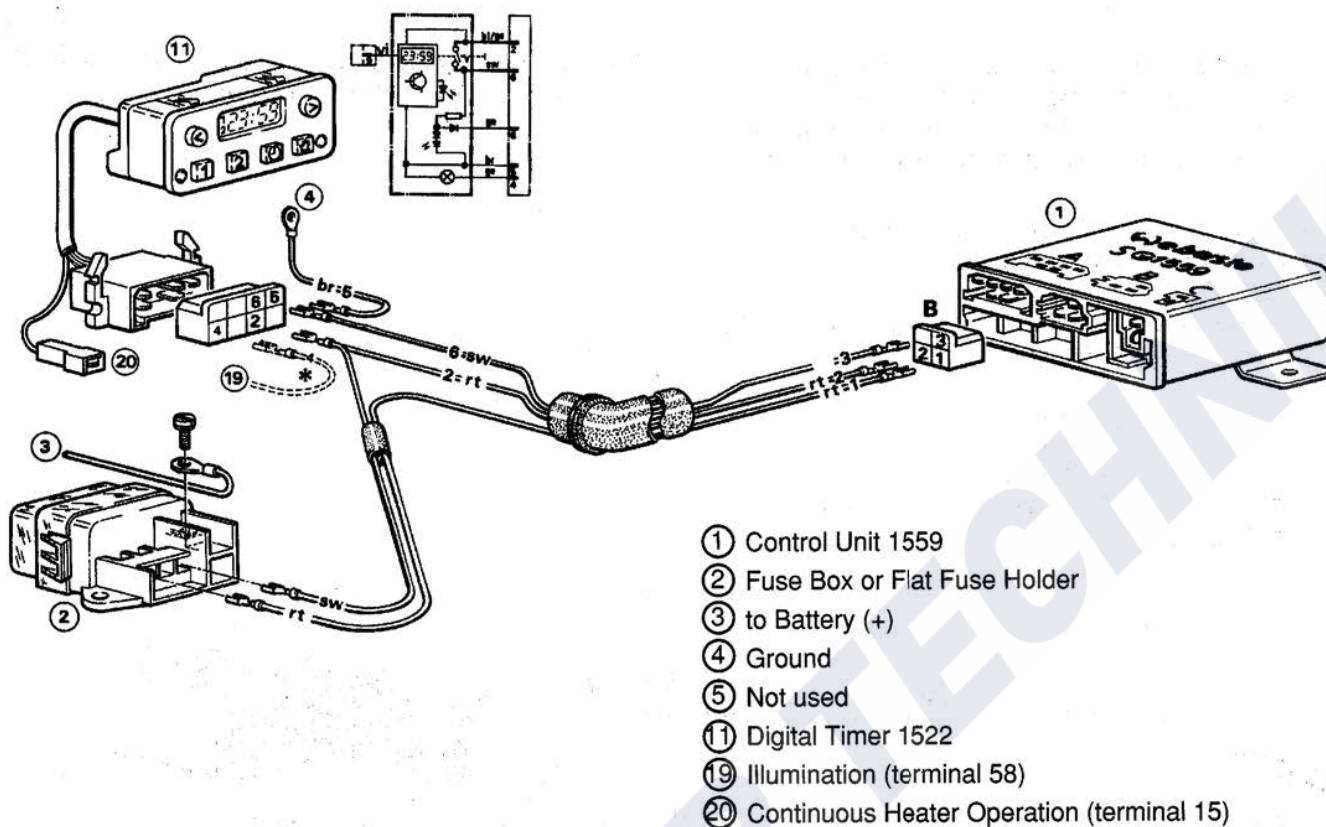

Before Conversion

Variant 1

Connection Standard Wiring Harness: Control Unit 1559 with Digital Timer and Flat Fuse Holder

7 Repair and Disassembly Instructions

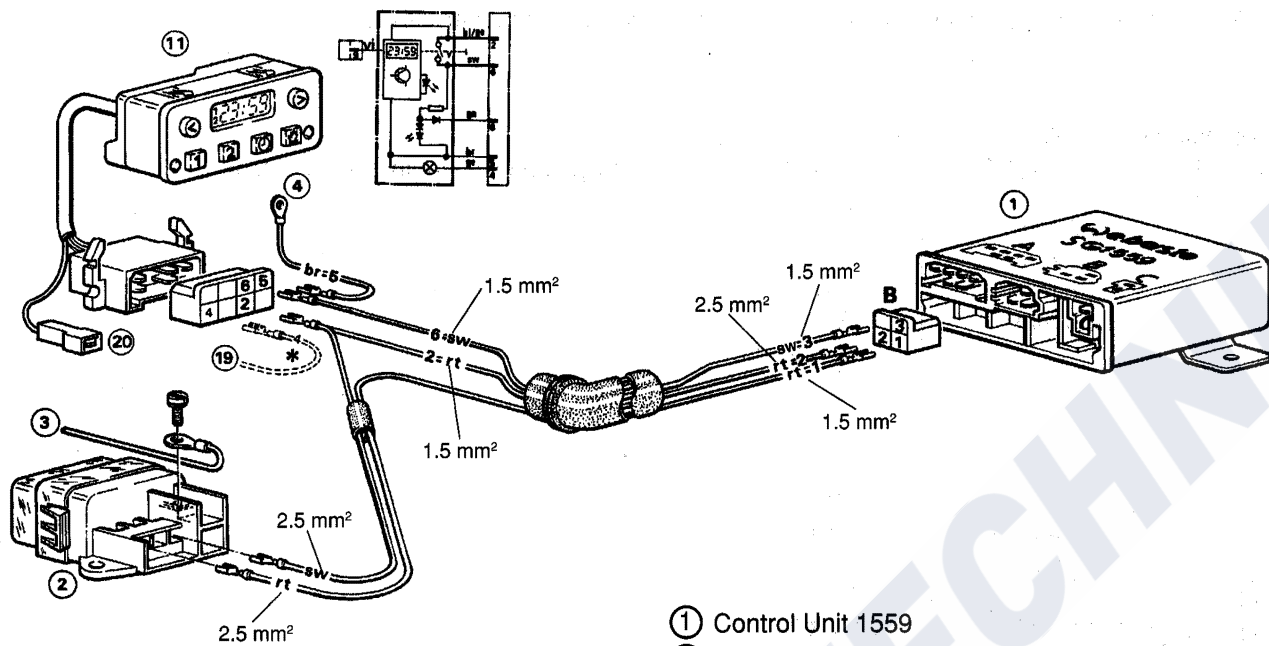

- ① Control Unit 1559
- ② Fuse Box or Flat Fuse Holder
- ③ to Battery (+)
- ④ Ground
- ⑪ Digital Timer 1522
- ⑲ Illumination (terminal 58)
- ⑳ Continuous Heater Operation (terminal 15)

Before Conversion Variant 2

Connection Wiring Harness: Control Unit 1559 with Digital Timer and Flat Fuse Holder

Conversion

Note The table is also applicable for conversion of self-production wiring harnesses.

From connector (B) Contact	Wire Gauge *	To connector (A) Contact
B1	1.5 mm ²	A2
B2	2.5 mm ²	A1
B3	1.5 mm ²	A6
-	4.0 mm ²	A4 br (manufacture)

* Up to a wire length of max. 7.5 m

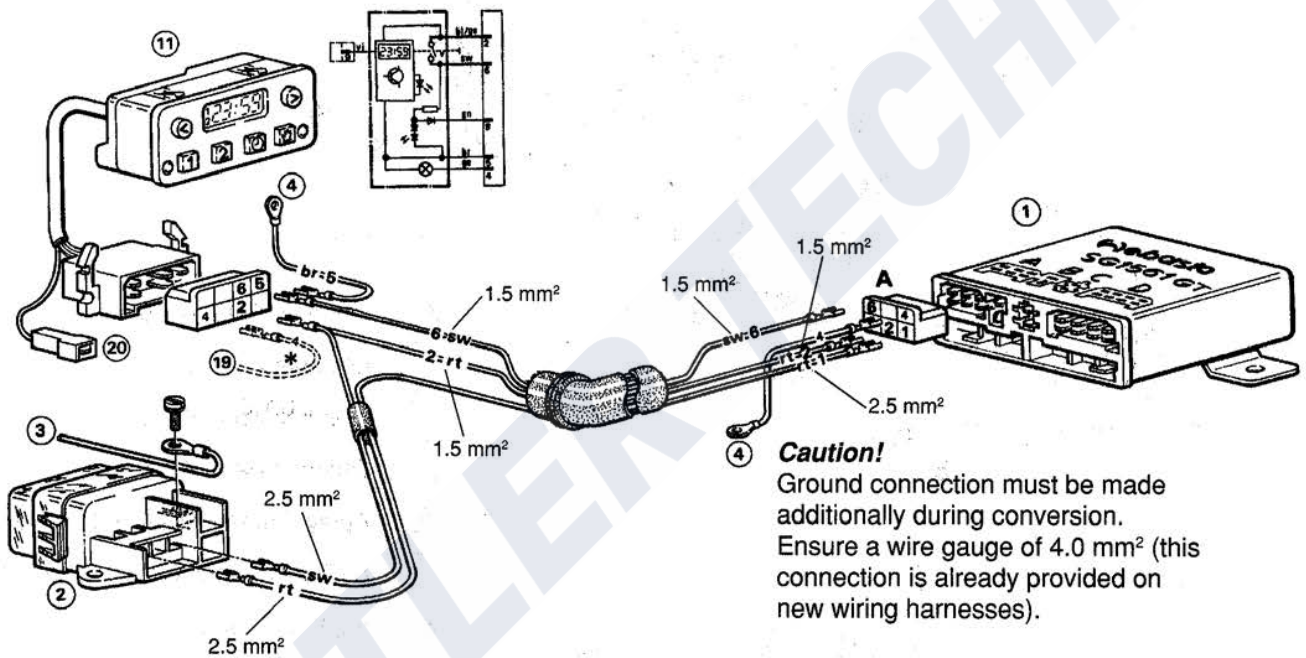

For conversion of control unit 1559 to control unit 1561 GT with integral glow pulsing the connector terminals must be removed from the 4-pole connector and inserted again into the new 6-pole socket (Ident-No. 328529) according to the Table and Figure.

- ① Control Unit 1561 GT
- ② Fuse Box or Flat Fuse Holder
- ③ to Battery (+)
- ④ Ground
- ⑪ Digital Timer 1522
- ⑲ Illumination (terminal 58)
- ⑳ Continuous Heater Operation (terminal 15)

After Conversion
Variant 2

Connection Wiring Harness: Control Unit 1561 GT with Digital Timer and Flat Fuse Holder

7 Repair and Disassembly Instructions

7.4 Disassembly Instructions

(For Index refer to Spare Parts List HL 18B/D and Air Top 18)

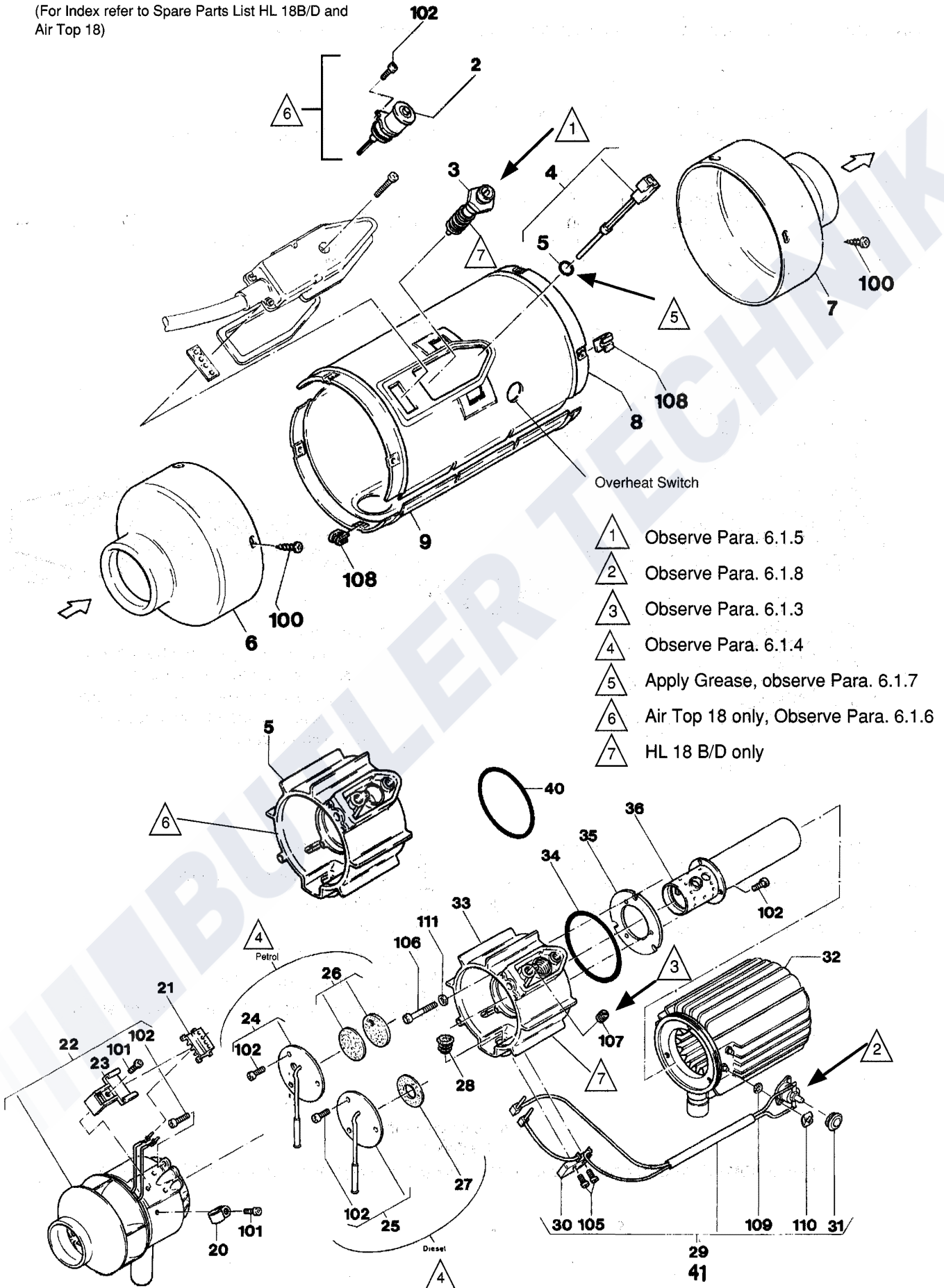

8 Maintenance

The heater should be started in regular time intervals (monthly) also during the summer season. After or before every heater operation period the following maintenance should be performed for reasons of functional safety:

8.1 Test and Maintenance Procedures

- Clean heater exterior (prevent the ingress of water)
- Check electrical connections for corrosion and loose contacts (also dosing pump and control unit).
- After cleaning the engine compartment the electrical connections have to be dried as required.
- Check exhaust silencer and exhaust pipes for damage, loose fit, obstructions, and leaks.
- Check combustion air pipe for damage (kink) and obstructions.
- Check connections of fuel lines, fuel taps, dosing pump with membrane dampener, as well as heater for leakage.

Note: The heat exchanger must be replaced after 10 years.

8.2 Functional Test

Check CO₂-value of exhaust air (refer to 6.1.3) as well as heating performance in the vehicle. In case of failures, refer to 4., Troubleshooting.

8.3 Spares Provisioning

A continuously updated Spare Parts List for spares provisioning of heaters may be requested from Webasto.

9 Wiring diagrams • Plans de connexions • Schemi collegamenti elettrici

SG 1559

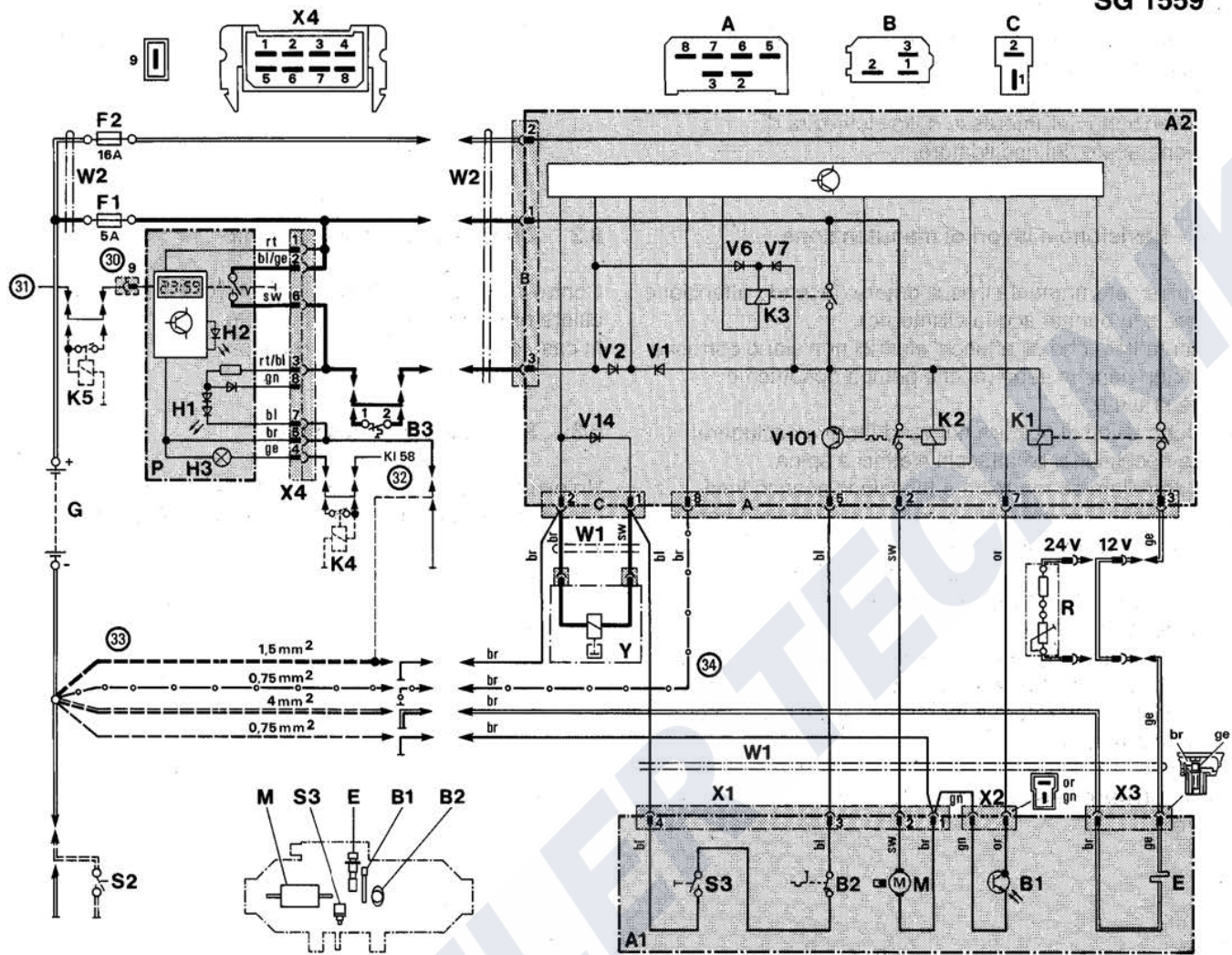

Fig. 3: Automatic control for HL 18 B/D, 12 and 24 volts, with digital timer and battery switch (B 8014-3000-0001) control unit SG 1559
 Illus. 3: Branchement automatique pour HL 18 B/D, 12 et 24 V, avec minuterie et robinet de batterie (B 8014-3000-0001) Boîtier de commande SG 1559

Fig. 3: Comando automatico per HL 18 B/D, 12 e 24 V, funzionamento con timer e staccabatteria (B 8014-3000-0001) Centralina SG 1559

Application examples, see Webasto Information No. 184
 Exemple de montage, voir Information Webasto No. 184
 Esempio d'impiego, vedere Information Webasto Nr. 184

Functional diagram see page 19
 Diagramme de fonction voir page 63
 Per diagramma di funzionamento vedere page 107

Wire Ganges Sections des conducteurs Sezioni dei cavi	
< 7,5m	7,5 - 15m
0,75mm ²	1,5mm ²
1,0mm ²	1,5mm ²
1,5mm ²	2,5mm ²
2,5mm ²	4,0mm ²
4,0mm ²	6,0mm ²

Wire colours Couleurs des câbles Colori dei cavi			
bl	blue	bleu	blu
br	brown	brun	marrone
ge	yellow	jaune	giallo
gn	green	vert	verde
gr	gray	gris	grigio
or	orange	orange	aranc.
rt	red	rouge	rosso
sw	black	noir	nero
vi	violet	violet	violetto
ws	white	blanc	bianco

Legend page 143
 Légende page 143
 Leggenda pagina 143

- | | | |
|---|--|---|
| <p>③0 Digital Timer P:
Positive at pin 9: continuous operation with instant heat
No positive feed: heating for 1 hour only</p> <p>③1 To vehicle terminal 75, if available, otherwise terminal 15</p> <p>③2 Vehicle illumination</p> <p>③3 Dashed lines and relays K4 und K5 applicable only if battery switch S2 is used</p> <p>③4 For petrol heater remove this connection</p> | <p>③0 Minuterie P:
Branchement 9 au plus: fonctionnement indéfini pour Mise en route immédiate
Cosse 9 débranchée: fonctionnement 1 heure</p> <p>③1 vers véhicule + 75 (si présent), sinon + 15</p> <p>③2 éclairage du véhicule</p> <p>③3 Conduites rayées ainsi que relais K4 et K5 seulement nécessaires lorsqu'il y a un robinet de batterie S2</p> <p>③4 Pour chauffage à essence supprimer ce branchement</p> | <p>③0 Timer digitale P:
positivo su attacco 9: funzionamento continuo con riscaldamento immediato
senza positivo su attacco 9: durata riscaldamento 1 h</p> <p>③1 al veicolo morsetto 75 se esistente, altrimenti morsetto 15</p> <p>③2 illuminazione veicolo</p> <p>③3 linee tratteggiate e relè K4 e K5 solo con impiego dell'interruttore batteria S2</p> <p>③4 per riscaldatore a benzina togliere questo attacco</p> |
|---|--|---|

9 Wiring diagrams • Plans de connexions • Schemi collegamenti elettrici

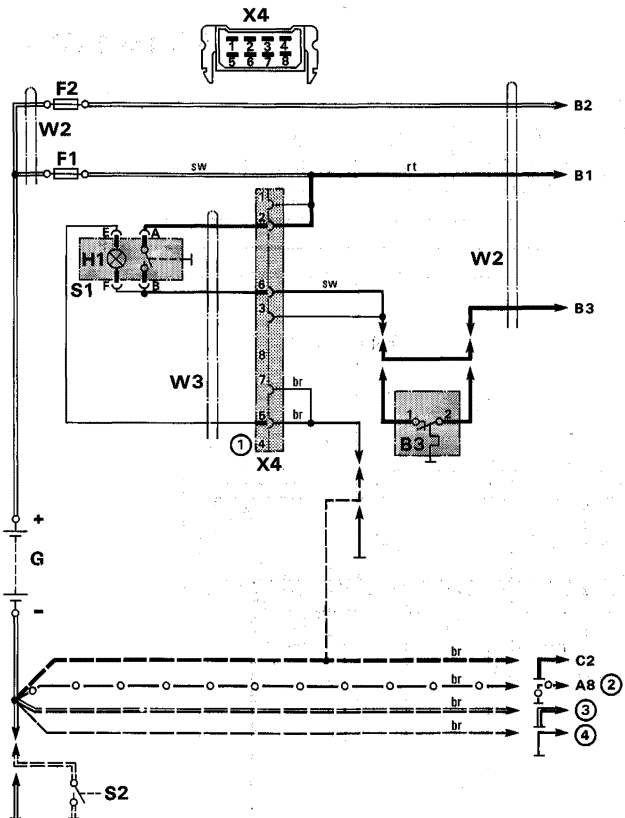

Fig. 4: Application example - 12 and 24 volts

Example applies to:

- operation with/without battery switch,
- operation with/without room thermostat,
- operation with ON - OFF switch.

Use in conjunction with automatic control wiring diagram B 8014-3000-0001 (page 142). Dashed lines applicable only if battery switch S2 is used.

Illus. 4: Exemple de montage 12 et 24 Volt

Exemple de montage valable pour:

- utilisation avec ou sans coupe-batterie
- utilisation avec ou sans thermostat d'ambiance,
- utilisation avec commutateur Marche/Arrêt

Valable uniquement pour commande automatique B 8014-3000-0001 (page 142) Conduites rayées seulement nécessaires lorsqu'il y a un robinet de batterie S2.

Fig. 4: Esempio d'impiego 12 e 24 V

L'esempio d'impiego è valido per:

- funzionamento con/senza interruttore batteria,
- funzionamento con/senza termostato ambiente,
- funzionamento con interruttore accends/spegnim.

Valido solo per comando automatico B 8014-3000-0001 (pagina 142)

Le linee tratteggiate sono in alternativa e solo con impiego dell'interruttore batteria S2.

- ① Remove wire terminal 4! / Supprime le branchement 4! / Togliere il morsetto 4!
- ② only for Diesel heaters / seulement pour appareils diesel / solo per versione diesel
- ③ Glow plug (of heater) / Bougie à inc. (à chauffage) / Candela (a riscaldatore)
- ④ Motor and flame detector (of heater) / Moteur et contrôleur de flamme (à chauff.) / Motore e fotosensenza (a riscaldatore)

- A fitted in the heater / dans l'appareil de chauffage / montato su riscaldatore
- B loose parts / livré séparément / particolari forniti sciolti
- C only if required / option / solo a richiesta
- D fitted in vehicle / faisant partie du véhicule / componente del veicolo

● permanent fitting / indispensable / corredo standard

○ possible, depend. on specification or build date / selon livraison ou définition / a seconda del corredo fornitura e del modello

Item Rep. Pos.	Description Designation Denominazione	Remarks Remarques Specificazioni	A	B	C	D
A1	Heater HL 18 Appareil de chauffage HL 18 Riscaldatore HL 18	2 pole insulated return sans masse non collegato a massa		●		
A2	Control unit Boîtier de commande Centralina	SG 1559		●		
B1	Flame detector Contrôleur de flamme Fotosensenza	ensure correct polarity polarité importante fare attenzione alla polarità	●			
B2	Thermostat Thermostat Termostato	Overheat Limiteur de température Termolimitadtre		●		
B3	Thermostat Thermostat Termostato	Room thermostat Thermostat d'ambiance Termostato ambiente			○	
E	Glow Plug Bougie à incandescence Candela			●		
F1	Fuse 5A Fusible 5A Fusibile 5A	Vehicle fuse DIN 72581 Sécurité DIN 72581 Fusibile DIN 72581		●		
F2	Fuse 16A Fusible 16A Fusibile 16A	Vehicle fuse DIN 72581 Sécurité DIN 72581 Fusibile DIN 72581		●		
G	Battery Batterie Batteria					●
H1	Green LED Voyant vert LED verte	Operation indicator (in item P or S1) Témoin de fonction (dans rep. P) spia funzionamento (in pos. P)		●		
H2	Yellow LED Voyant jaune LED giallo	programteady light (in item P) pré-sélection (dans rep. P) spia preselez. attivata (in Pos. P)				
H3	Lamp Voyant Lampada	symbol lighting (in item P) éclairage (dans rep. P) illuminazione simboli (in pos. P)				
K1	Relay (in item A2) Relais (dans rep. A2) Relè (in pos. A2)	for glow plug pour incandescence per incandescenza				
K2	Relay (in item A2) Relais (dans rep. A2) Relè (in pos. A2)	for item M for drive assembly pour rep. M pour entraînement per pos. M				
K3	Relay (in item A2) Relais (dans rep. A2) Relè (in pos. A2)	for purge cycle/reversed pol. protect. pour arrêt retardé per corsa ritorno e protez. poli invert				
K4	Relay Relais Relè	only needed with battery isolation switch on negative pole seulement pour montage avec coupe batterie dans (-) necessari solo con interruttore batteria nel (-)			○	
K5	Relay Relais Relè				○	

Item Rep. Pos.	Description Designation Denominazione	Remarks Remarques Specificazioni	A	B	C	D
M	Motor Moteur Motore	for drive assembly de fonctionnement per gruppo bruciatore		●		
P	Digital timer Minuterie Timer digitale	for programmed operation affichage digital per funzionamento con.preselezione			○	
R	Resistor Résistance Resistenza	resistor for 24 V résistance pour 24 V. supplémentaire per 24 V			○	
S1	Switch Commutateur Interruttore	on-off marche-arrêt on-off		●		
S2	Switch Commutateur Interruttore	battery switch robinet de batterie staccabatteria				○
S3	Switch Commutateur Interruttore	safety switch commutateur de sécurité interruptore di sicurezza		●		
V14	Diode Diode Diode	freewheel diode for item Y (in item A2) pour rep. Y (dans rep. A2) per pos. Y (in pos. A2)				
V101	Transistor Transistor Transistor	for item Y (in item A2) pour rep. Y (dans rep. A2) per pos. Y (in pos. A2)				
W1	Wiring harness Faisceau Fascio cavi	control unit/heater/dosing pump pour Rep. A2 / A1 / Y. centralina/riscaldatore/pompa comb.		●		
W2	Wiring harness Faisceau Fascio cavi	fuse box/X4/control unit boîtier fusible/X4/boîtier de com. scatola fusibili/X4/centralina		●		
W3	Wiring harness Faisceau Fascio cavi	adaptor X4 / S2 adaptateur X4 / S2 adattore X4 / S2		●		
X1	Four-pole connector Raccordement 4 pôles Collegamento a spina quadripol.	contained in cap dans le capot nel connettore cavi				
X2	Two-pole connector Raccordement 2 pôles Collegamento a spina bipolare	contained in cap dans le capot nel connettore cavi				
X3	Two-pole connector Raccordement 2 pôles Collegamento a spina bipolare	coaxial coaxial coassiale				
X4	Eight-pole Connector Raccordement 8 pôles Collegamento a spina ottopol.	to W2 or P or W3 dans W2 ou P su W2 opp. P				
Y	Dosing pump Pompe doseur Pompa combustibile					●

9 Wiring diagrams • Plans de connexions • Schemi collegamenti elettrici

SG 1561 GT

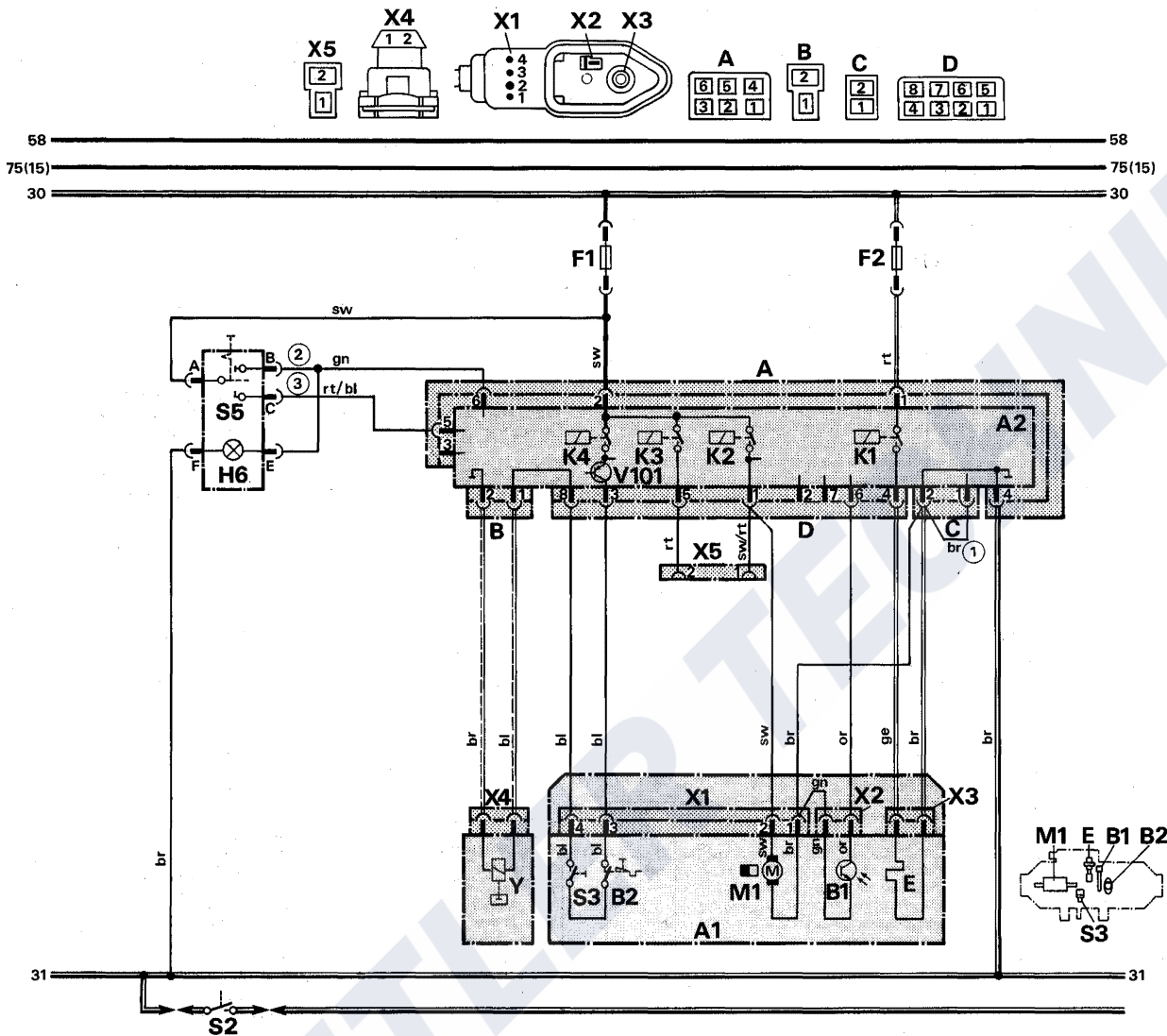

Fig. 5: Automatic control for HL 18 B/D, 12 and 24 volts, (25109A)

Fig. 5: Branchement automatique pour HL 18 B/D, 12 et 24 volts, (25109A)

Fig. 5: Comando automatico per riscaldatore HL 18 B/D, 12 e 24 Volt, (25109A)

- Operation with switch (without part-load operation)

- Fonction avec l'interrupteur (sans le régime partiel)

- Funzionamento con interruttore (senza potenza ridotta)

Function:

- Switching on "heater" with switch.
- The heater is controlled manually from "full heat" to "off" during the heating operation.
- Green LED in switch: operation indicator.

Fonctionnement:

- Mise en service "chauffage" avec l'interrupteur
- L'appareil de chauffage est commuté par la main de "plein régime" à "arrêt" pendant le chauffage.
- LED vert dans l'interrupteur: indicateur de fonctionnement.

Funzionamento:

- Mediante interruttore portare su "riscaldamento".
- Durante il riscaldamento il riscaldatore viene commutato manualmente su "potenza piena" a "potenza ridotta".
- LED verde nell'interruttore: controllo accensione

- ① For petrol heater, remove this connection.
- ② Heating.
- ③ Ventilation

- ① Pour chauffage à essence supprimer ce branchement
- ② Chauffage
- ③ Ventilation

- ① Rimuovere questo attacco per gli apparecchi a benzina.
- ② Riscaldamento
- ③ Ventilazione

Legend see page 155.

Légende voir la page 155.

Per leggenda vedere pag. 155.

Functional diagram see page 20.

Diagramme de fonction voir page 64.

Per diagramma di funzionamento vedere pag. 108

SG 1561 GT

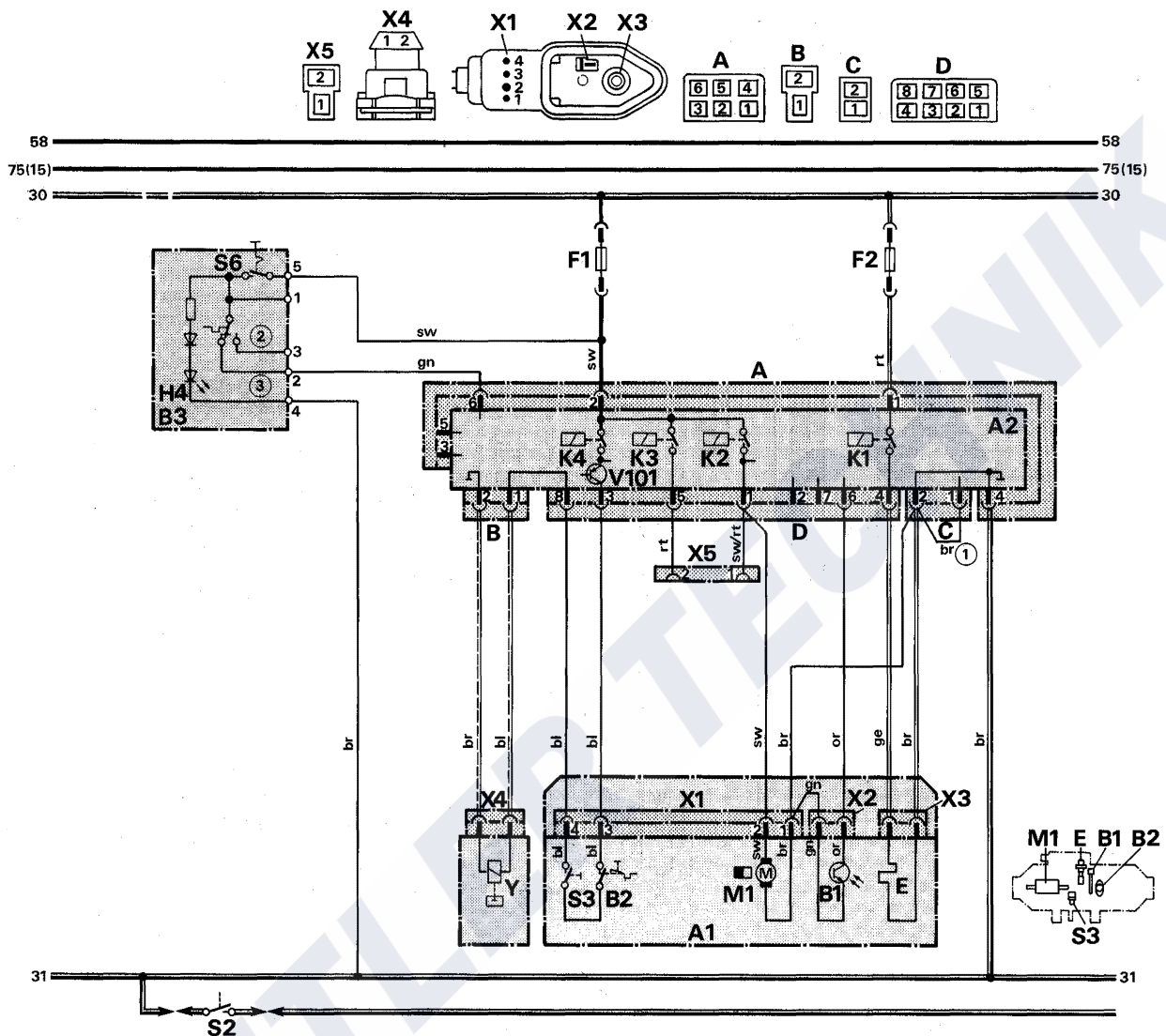

Fig. 6: Automatic control for HL 18 B/D, 12 and 24 volts, (25108A)

Fig. 6: Branchement automatique pour HL 18 B/D, 12 et 24 volts, (25108A)

Fig. 6: Comando automatico per riscaldatore HL 18 B/D, 12 e 24 Volt, (25108A)

● Operation with mechanical room thermostat (without part-load operation)

Function:

- Switch: off - heating.
- The room thermostat switches the heater on and off.
- Green LED in room thermostat: operation indicator.

- ① For petrol heater, remove this connection.
- ② Warm.
- ③ Cold.

Legend see page 155.

Functional diagram see page 20.

● Fonction avec le thermostat d'ambiance mécanique (sans le régime partiel)

Fonctionnement:

- Interrupteur: mise en circuit et mis hors circuit.
- Le thermostat d'ambiance commute de "mise en circuit" à "mise hors circuit" l'appareil de chauffage.
- LED vert dans le thermostat d'ambiance: indicateur de fonctionnement

- ① Pour chauffage à essence supprimer ce branchement.
- ② Chaud.
- ③ Froid.

Légende voir la page 155.

Diagramme de fonction voir page 64.

● Funzionamento con termostato ambiente meccanico (senza potenza ridotta).

Funzionamento:

- Interruttore: spegnimento - riscaldamento
- Il termostato ambiente accende e spegne il riscaldatore
- LED verde nel termostato ambiente: spia funzionamento

- ① Rimuovere questo attacco per gli apparecchi a benzina.
- ② Caldo.
- ③ Freddo.

Per leggenda vedere pag. 155.

Per diagramma di funzionamento vedere pag. 108

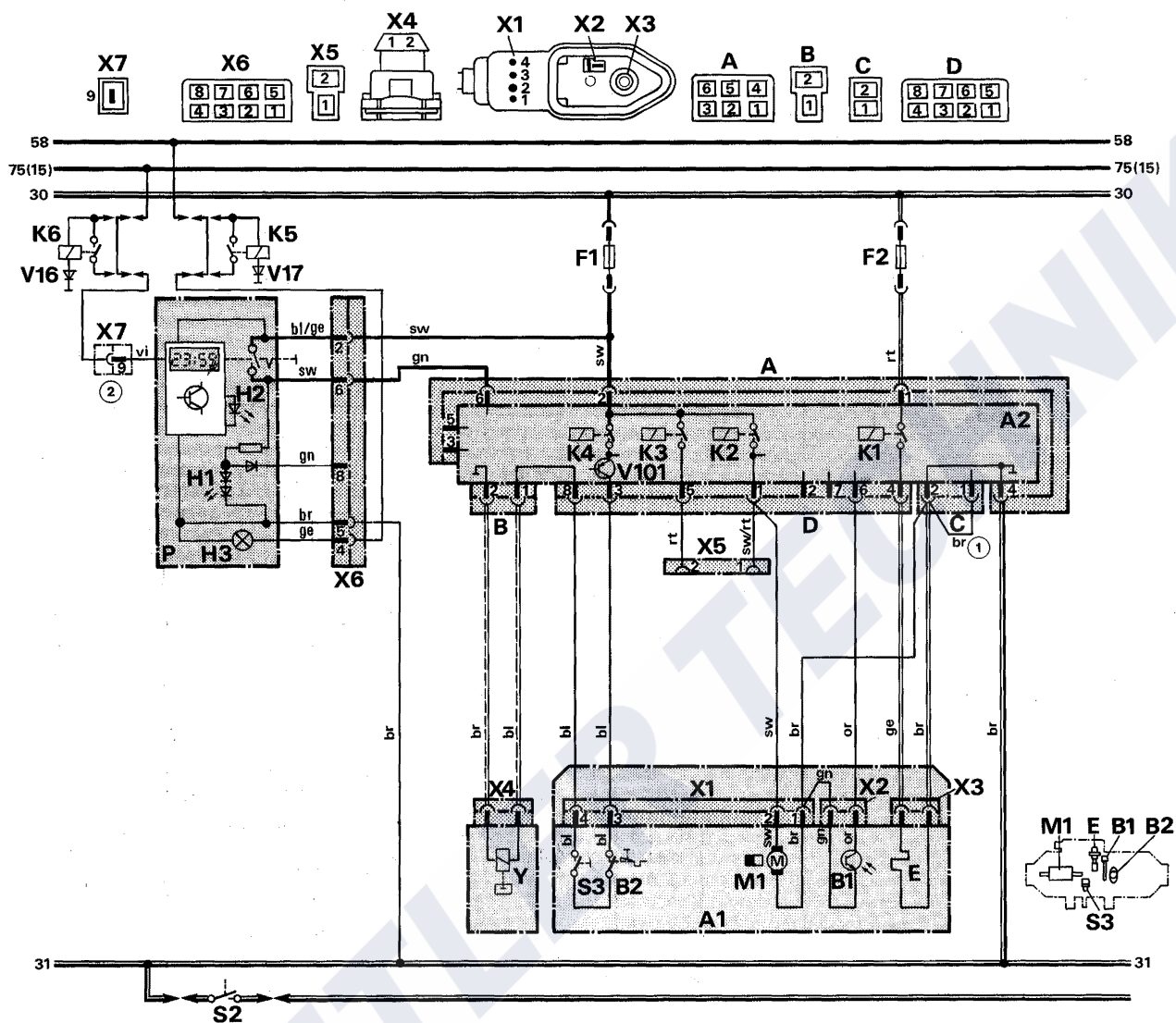

Fig. 7: Automatic control for HI 18 B/D, 12 and 24 volts, (20247A)

Bild 7: Branchement automatique pour HL 18 B/D, 12 et 24 volts, (20247A)

Bild 7: Comando automatico per riscaldatore HL 18 B/D, 12 e 24 Volt, (20247A)

● Operation with digital timer 1522 (without part-load operation)

Function:

- Switching on "heater" with digital timer; pre-selection mode "instant heating" (definite or indefinite).
- The heater operates in "full heat" during heating time and is switched off either by digital timer or manually.
- Green LED in digital timer: operation indicator.

- ① For petrol heater, remove this connection.
- ② Digital timer P:
 - terminal 9 is connected to positive: continuous operation with "instant heating";
 - terminal 9 is not connected to positive: heating period 1 hour.

● Fonction avec la montre de pré-sélection (sans le régime partiel).

Fonctionnement:

- Mise en service "chauffage avec la montre de pré-sélection; présélection "chauffage immédiat" (limitée ou illimitée).
- L'appareil de chauffage fonctionne en "plein régime" et il est hors circuit par la montre ou la main.
- LED vert dans la montre de pré-sélection: indicateur de fonctionnement.

- ① Pour chauffage à essence supprimer ce branchement
- ② Montre de pré-sélection P:
 - branchement 9 au plus: fonctionnement indéfini pour "mise en service immédiate";
 - sans branchement 9 au plus: chauffage 1 heure.

● Funzionamento con timer digitale 1522 (senza potenza ridotta).

Funzionamento:

- Portare su "riscaldamento" con il timer digitale; tipo di preselezione "riscaldamento immediato" (limitato o illimitato).
- Il riscaldatore funziona a "potenza piena" e può venire spento con il timer o manualmente
- LED verde nel timer digitale: spia funzionamento

- ① Rimuovere questo attacco per gli apparecchi a benzina.
- ② Timer digitale P:
 - positivo su attacco 9: funzionamento con riscaldamento immediato;
 - senza positivo su attacco 9: durata riscaldamento 1 ora.

Legend see page 155.
Functional diagram see page 20.

Légende voir la page 155.
Diagramme de fonction voir page 64.

Per leggenda vedere pag. 155.
Per diagramma di funz. vedere pag. 108

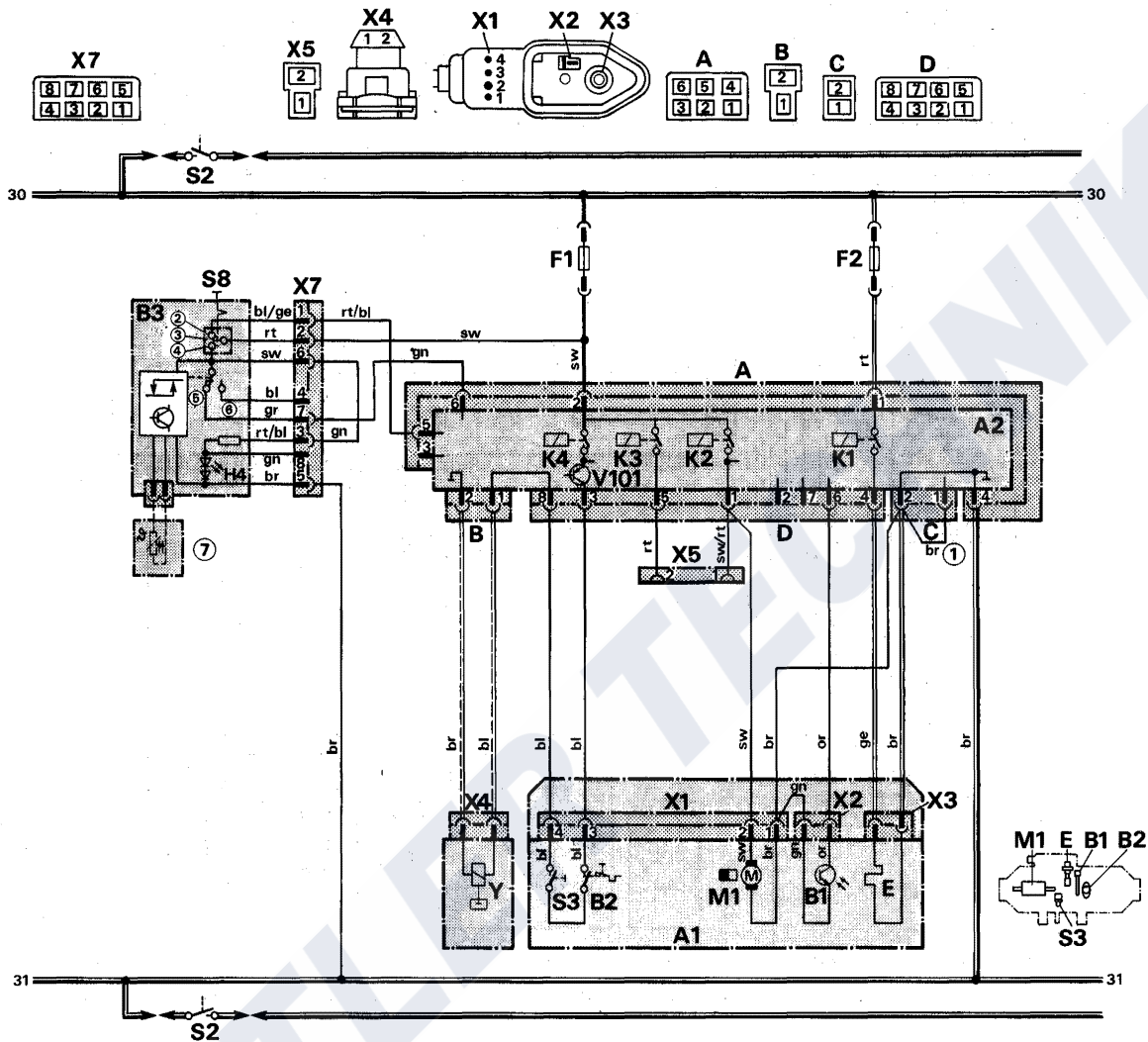

Fig. 8: Automatic control for HL 18 B/D, 12 and 24 volts, (20459A)

● Operation with electronic room thermostat (without part-load operation)

Function:

- Switching on "ventilation" with switch in room thermostat.
- Switching on "heater" with switch in room thermostat: indefinite (permanent heating).
- The room thermostat controls the heater within "full heat" to "off" during heating operation.
- Green LED in room thermostat: operation indicator.

- ① For petrol heater, remove this connection.
- ② Ventilation
- ③ Off.
- ④ Heating.
- ⑤ Cold.
- ⑥ Warm.
- ⑦ If an external temperature sensor is connected, the wire bridge on the top of the housing must be removed. After that the internal temperature sensor is not in function. It is not possible to reset the system!

Legend see page 155.
Functional diagram see page 20.

Bild 8: Branchement automatique pour HL 18 B/D, 12 et 24 volts (20459A)

● Fonction avec le therm. d'ambiance électronique (sans le régime) partiel.

Fonctionnement:

- Mise en service "ventilation" avec l'interrupteur de thermostat d'ambiance.
- Mise en service "chauffage" avec l'interrupteur de thermostat d'ambiance: illimitée (chauffage permanent).
- Le thermostat d'ambiance commute l'appareil de chauffage de "plein régime" à "hors circuit".
- LED vert dans le thermostat d'ambiance: indicateur de fonctionnement.

- ① Pour chauffage à essence supprimer ce branchement.
- ② Ventilation
- ③ Mise hors circuit.
- ④ Chauffage.
- ⑤ Froid.
- ⑥ Chaud.
- ⑦ Lorsqu'une sonde de température externe est reliée, la connexion doit être séparée de boîtier de thermostat. La sonde de température interne n'est pas en fonction. Il n'est pas possible de rappeler le système!

Légende voir page 155.
Functional diagram see page 64.

Figura 8: comando automatico per riscaldatore HL 18 B/D, 12 e 24 Volt (20459A)

● Funzionamento con termostato ambiente elettronico (senza potenza ridotta)

Funzionamento:

- mediante interruttore del termostato ambiente portare su „ventilazione“
- mediante interruttore nel termostato ambiente portare su „riscaldamento“: illimitato (funzionamento continuo)
- Nel funzionamento di riscaldamento il riscaldatore viene regolato tramite il termostato ambiente tra „potenza piena“ e „disinserimento“.
- LED verde nel termostato ambiente: spia di funzionamento

- ① Rimuovere questo attacco per gli apparecchi a benzina.
- ② Ventilazione
- ③ Spegnimento
- ④ Riscaldamento
- ⑤ Freddo
- ⑥ Caldo
- ⑦ Se si impiega un termosensore esterno è necessario togliere il ponte sul lato superiore del corpo. In tal modo viene messo fuori servizio il termosensore interno (non è possibile alcun ripristino!).

Per leggenda vedere pag. 155
Per diagramma di funz. vedere pag. 108.

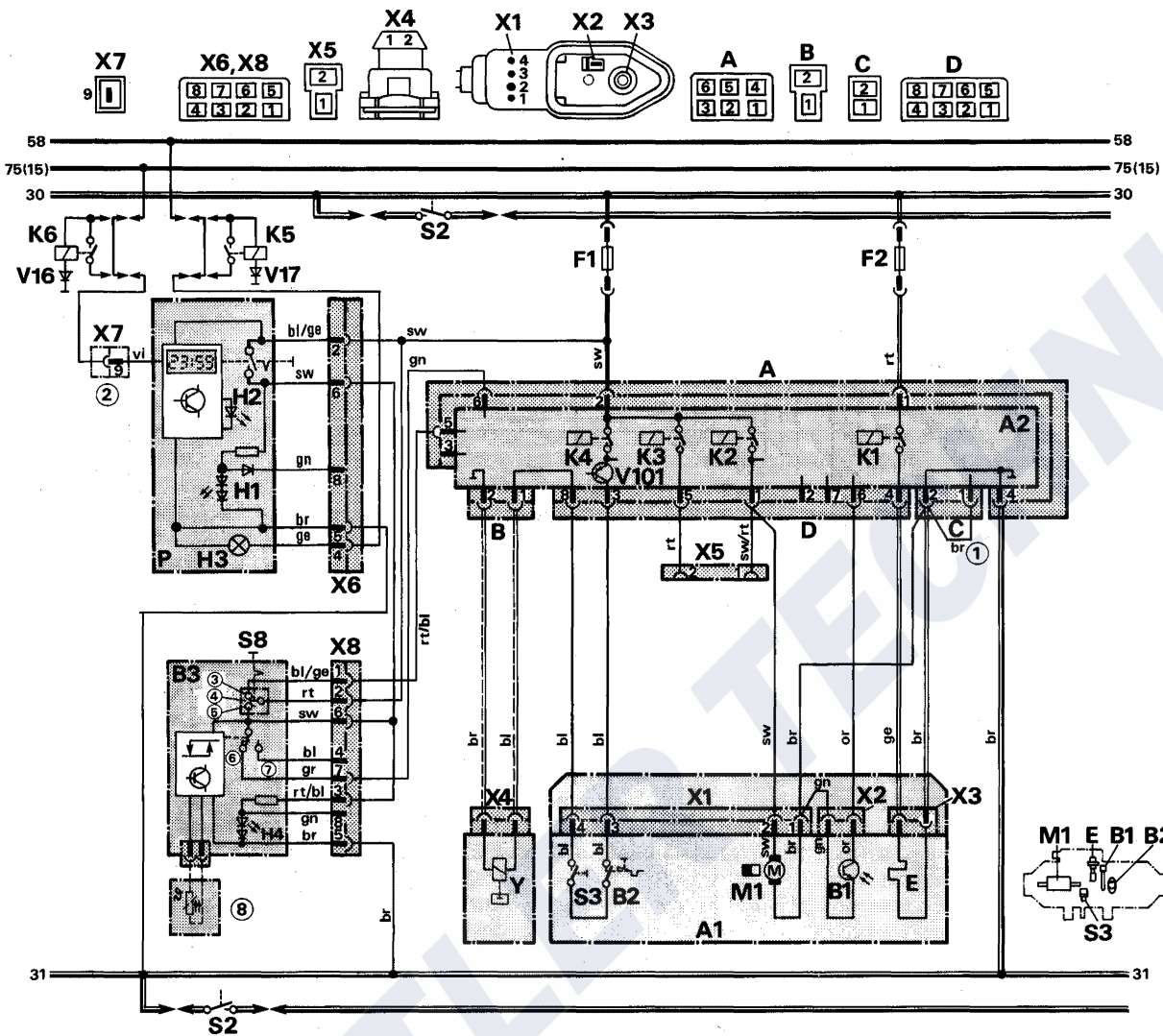

Fig. 9: Automatic control for HL 18 B/D, 12 and 24 volts, (20460A)

Fig. 9: Branchement automatique pour HL 18 B/D, 12 et 24 volts, (20460A)

Figura 9: comando automatico per riscaldatore HL 18 B/D, 12 e 24 Volt (20460A)

● Operation with digital timer and electronic room thermostat (without part-load operation)

- Function:
- Switching on "ventilation" with switch in room thermostat.
 - Switching on "heater" with digital timer; pre-selection "Instant heating" (definite or indefinite).
 - Switching on "heater" with switch in room thermostat: indefinite.
 - Green LED in digital timer: operation indicator.
 - Green LED in room thermostat: operation indicator.

- ① For petrol heater, remove this connection.
- ② Digital timer P:
 - pin 9 is connected to positive: indefinite operation for "immediate heating";
 - pin 9 is not connected to positive: heating period 1 hour
- ③ Ventilation
- ④ Off.
- ⑤ Heating.
- ⑥ Cool.
- ⑦ Warm.
- ⑧ If an external temperature sensor is connected, then the wire bridge on the top of the housing must be cut. After that the internal temperature sensor is not in function. It is not possible to reset the system!

Legend see page 155.
Functional diagram see page 20.

● Fonction avec la montre de pré-sélection et le thermostat d'ambiance électronique (sans le régime partiel).

- Fonctionnement:
- Mise en service "ventilation" avec l'interrupteur de thermostat d'ambiance.
 - Mise en service "chauffage" avec montre de pré-sél; présélection "chauff. immédiat" (limitée ou illimitée).
 - Mise en service "chauffage" avec l'interrupteur de thermostat d'ambiance: illimitée.
 - LED vert dans la montre de pré-sélection: indicateur de fonctionnement.
 - LED vert dans le thermostat d'ambiance: indicateur de fonctionnement.

- ① Pour chauffage à essence supprimer ce branchem..
- ② Montre de pré-sélection P:
 - branchement 9 au plus: fonctionnement indéfini pour "mise en service immédiate";
 - sans branchement 9 au plus: chauffage 1 heure
- ③ Ventilation
- ④ Mise hors circuit.
- ⑤ Chauffage.
- ⑥ Froid.
- ⑦ Chaud.
- ⑧ Lorsqu'un senseur de température externe est reliée, la connexion doit être séparée de boîtier de thermostat. La sonde de température interne n'est pas en fonction. Il n'est pas possible de rappeler le système!

Légende voir page 155.
Diagramme de fonction voir page 64.

● Funzionamento con timer e termostato ambiente elettronico (senza potenza ridotta)

- Funzionamento:
- mediante interruttore del termostato ambiente portare su „ventilazione“
 - mediante timer portare su „riscaldamento“; funzionamento di preselezione riscaldamento immediato (limitato e illimitato)
 - mediante interruttore nel termostato ambiente portare su „riscaldamento“; illimitato
 - Nel funzionamento di riscaldamento il riscaldatore viene regolato tramite il termostato ambiente tra „potenza piena“ e „disinserimento“.
 - LED verde nel termostato ambiente: spia di funzionamento

- ① Rimuovere questo attacco per gli apparecchi a benzina.
- ② timer P
 - con positivo su attacco 9; funzionamento continuo nel caso di riscaldamento immediato
 - senza positivo su attacco 9; durata di riscaldamento 1 ora
- ③ Ventilazione
- ④ Spegnimento
- ⑤ Riscaldamento
- ⑥ Freddo
- ⑦ Caldo
- ⑧ Se si impiega un termosensore esterno è necessario togliere il ponte sul lato superiore del corpo. In tal modo viene messo fuori servizio il termosensore interno (non è possibile alcun ripristino).

Per leggenda vedere pag. 155.
Per diagramma di funz. vedere pag. 108.

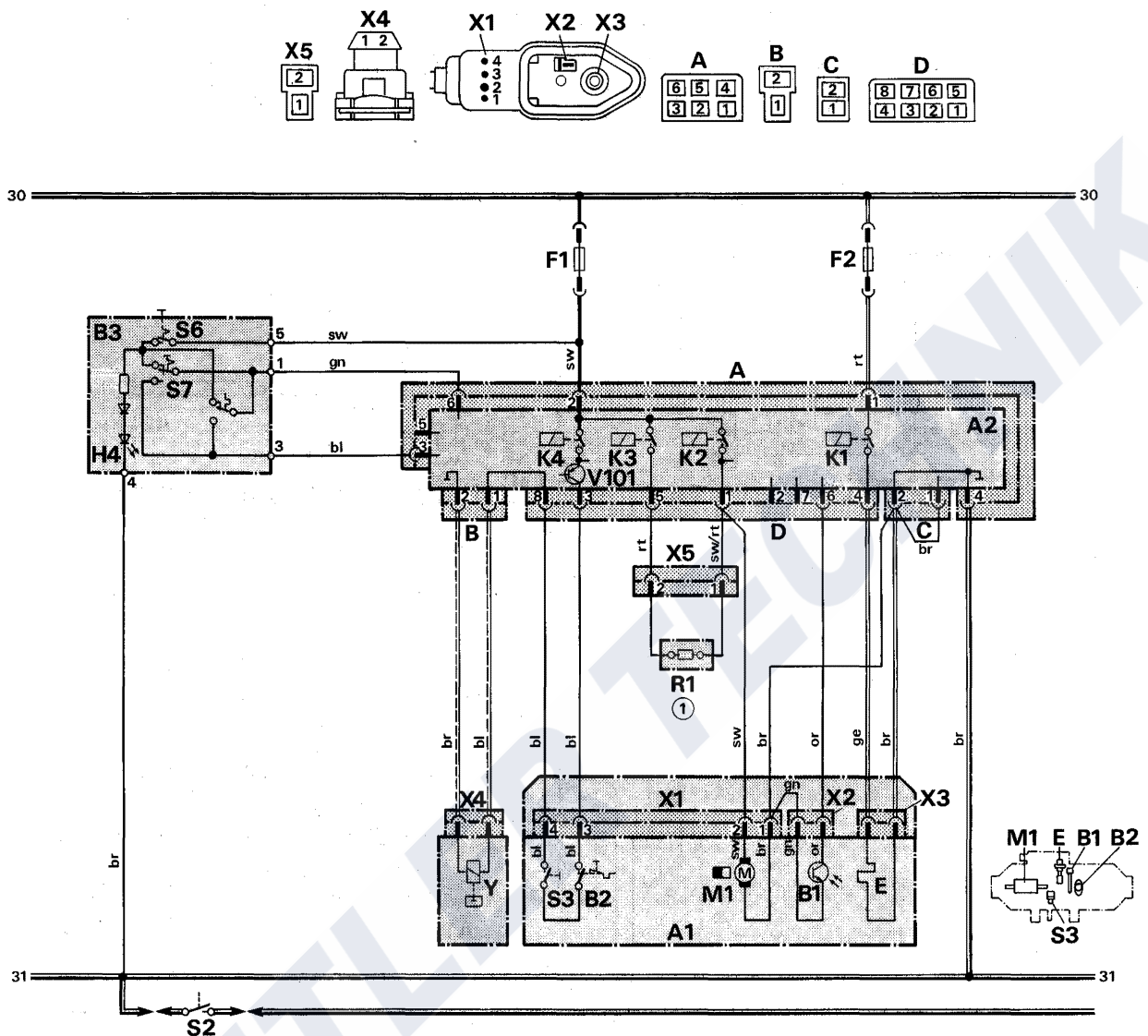

Fig. 10: Automatic control for HL 18 D with part-load operation, 12 and 24 volts, (20460A)

Fig. 10: Branchement automatique pour HL 18 D avec le régime partiel, 12 et 24 volts, (20460A)

Fig. 10: Comando automatico per riscaldatore HL 18 D con potenza ridotta, 12 e 24 Volt, (20460A)

● Operation with mechanical room thermostat.

● Fonction avec le thermostat d'ambiance mécanique.

● Funzionamento con termostato ambiente meccanico.

Function:

- Switching on "heater" with switch in room thermostat: indefinite (permanent heating).
- Dependent on position of switch S7 in the room thermostat the heater is switched in "full heat mode" or "reduced heat mode" during heating operation.
- Green LED in room thermostat: operation indicator

Fonctionnement:

- Mise en service "chauffage" avec l'interrupteur de thermostat d'ambiance: illimitée (chauffage permanent).
- Selon la position de l'interrupteur S7 dans le thermostat d'ambiance l'appareil de chauffage commute en "plein régime" ou "régime partiel".
- LED vert dans le thermostat d'ambiance: indicateur de fonctionnement.

Funzionamento:

- Portare su "riscaldamento" azionando l'interruttore del termostato ambiente: funzionamento illimitato (continuato).
- A seconda della posizione dell'interruttore S7 nel termostato ambiente si può scegliere tra "potenza piena" e "potenza ridotta".
- LED verde nel termostato ambiente: spia funzionamento

① R1 for reduced heat mode only.

① R1 seulement pour le régime partiel.

① R1 solo per potenza ridotta.

Legend see page 155.
Functional diagram see page 20.

Légende voir page 155.
Diagramme de fonction voir page 64.

Per leggenda vedere pag. 155.
Per diagramme di funz. vedere pag. 108.

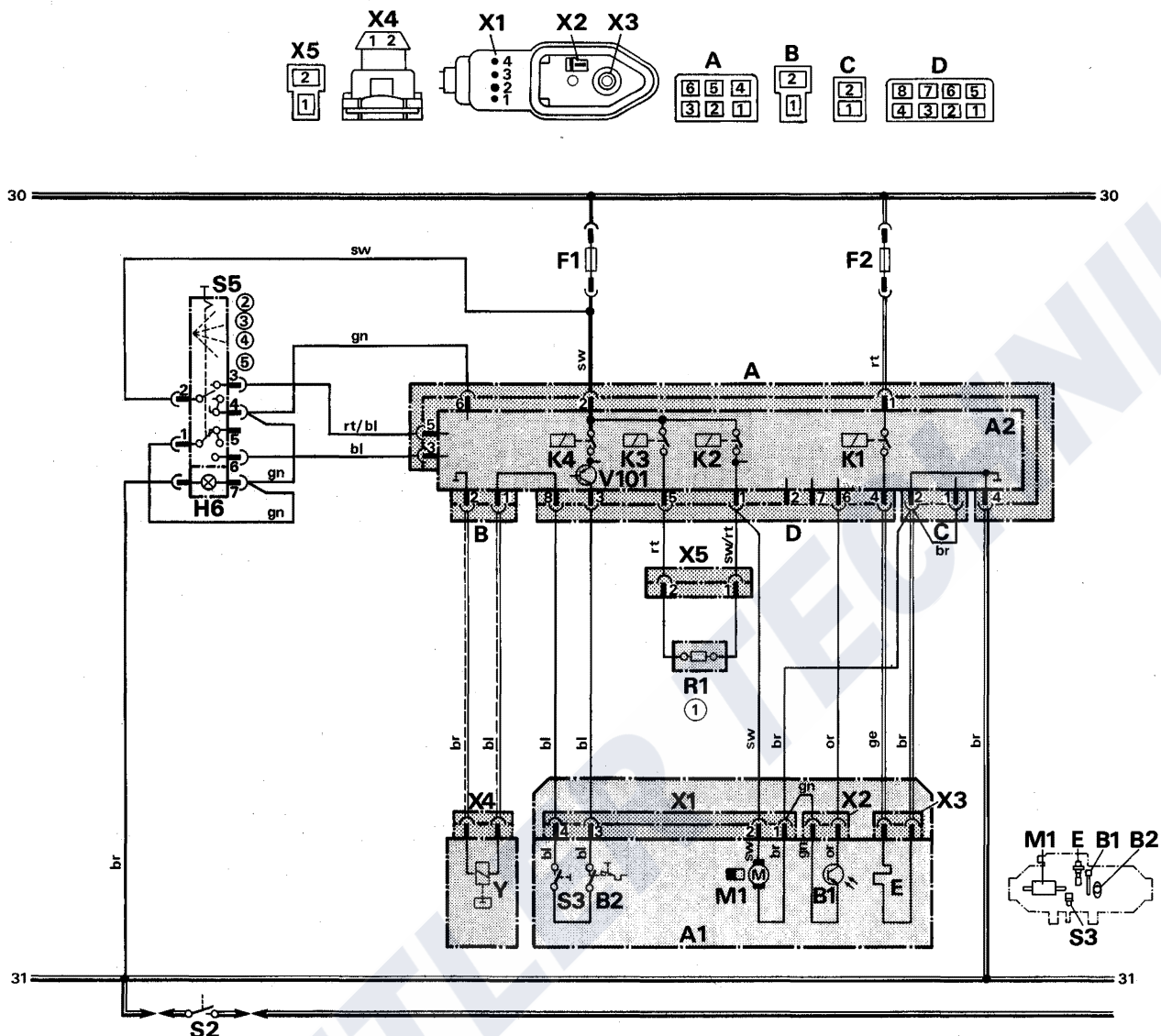

Fig. 11: Automatic control for HL 18 D with part-load operation, 12 and 24 volts, (14886A)

Fig. 11: Branchement automatique pour HL 18 D avec le régime partiel, 12 et 24 volts, (14886A)

Fig. 11: Comando automatico per riscaldatore HL 18 D con potenza ridotta, 12 e 24 Volt, (14886A)

● Operation with all-purpose switch.

● Fonction avec l'interrupteur universel

● Funzionamento con interruttore universale.

Function:

- Switching on "heater" with switch S5: indefinite (permanent heating).
- Dependent on position of switch S5 the heater is switched in "full heat mode" or "reduced heat mode" during heating operation.
- Green LED in switch S5: operation indicator.

Fonctionnement:

- Mise en service "chauffage" avec l'interrupteur S5: illimitée (chauffage permanent)
- Selon la position de l'interrupteur S5 l'appareil de chauffage commute en "plein régime" ou "régime partiel".
- LED vert dans l'interrupteur S5: indicateur de fonctionnement

Funzionamento:

- Portare su "riscaldamento" azionando l'interruttore universale: funzionamento illimitato (continuato).
- A seconda della posizione dell'interruttore S5 nel termostato ambiente si può scegliere tra "potenza piena" e "potenza ridotta".
- LED verde nell'interruttore S5: spia funzionamento.

- ① R1 for reduced heat mode only.
- ② Ventilation.
- ③ Off.
- ④ Full heat.
- ⑤ Reduced heat.

- ① R1 seulement pour le régime partiel.
- ② Ventilation.
- ③ Mise hors circuit.
- ④ Plein régime.
- ⑤ Régime partiel.

- ① R1 solo per potenza ridotta.
- ② Ventilazione.
- ③ Arresto.
- ④ Potenza piena.
- ⑤ Potenza ridotta.

Legend see page 155.
Functional diagram see page 20.

Légende voir page 155.
Diagramme de fonction voir page 64.

Per leggenda vedere pag. 155.
Per diagramma di funz. vedere page 108.

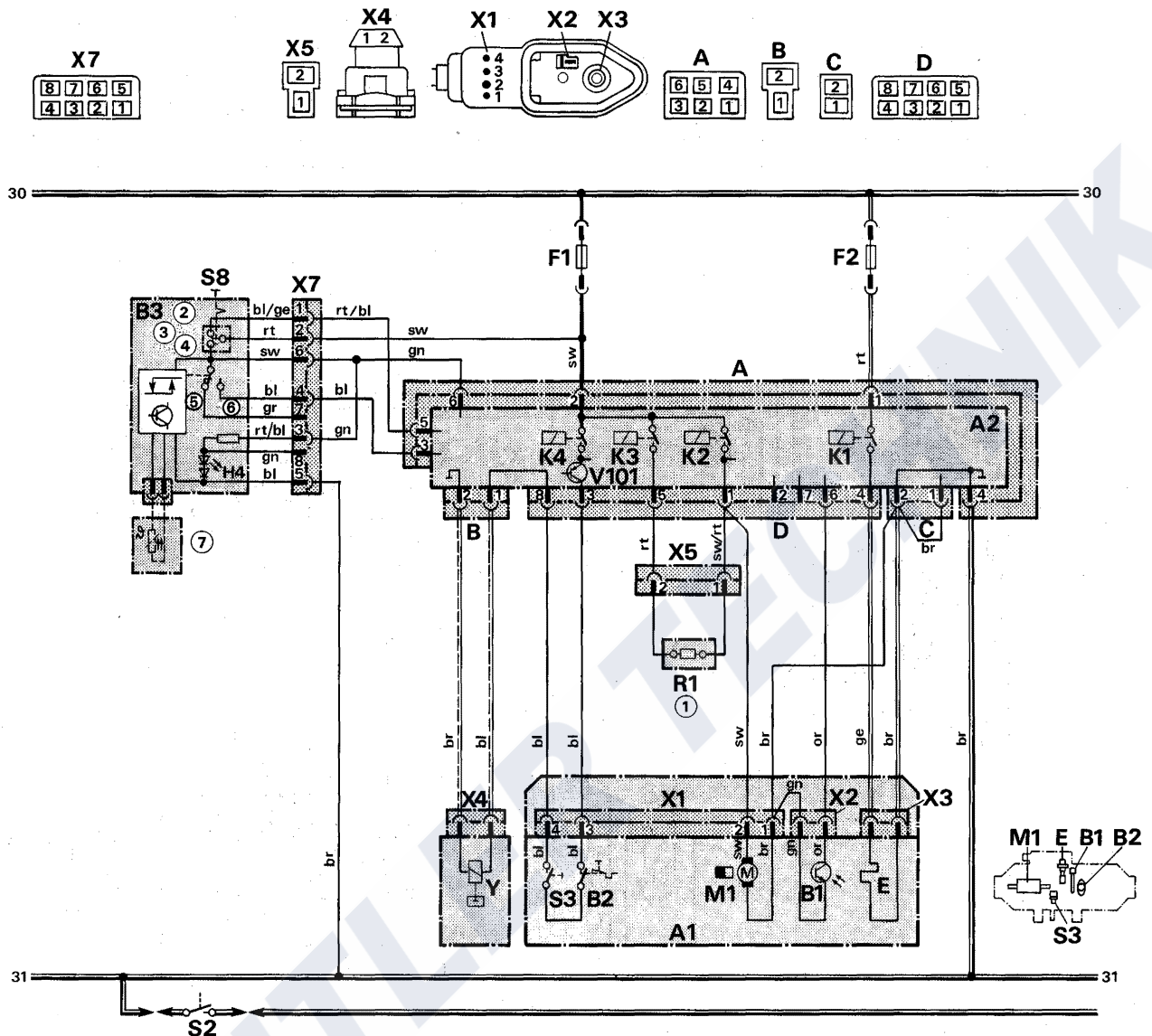

Fig. 12: Automatic control for HL 18 D with part-load operation, 12 and 24 volts, (15725A)

Fig. 12: Branchement automatique pour HL 18 D avec le régime partiel, 12 et 24 volts, (15725A)

Fig. 12: Comando automatico per riscaldatore HL 18 D con potenza ridotta, 12 e 24 Volt, (15725A)

● Operation with electronic room thermostat.

Function:

- Switching on "ventilation" with switch in room thermostat.
- Switching on "heater" with switch in room thermostat: indefinite (permanent heating).
- The room thermostat switches the heater from "full heat" to "reduced heat" during heating operation.
- Green LED in room thermostat: operation indicator.

- ① R1 for reduced heat mode only.
- ② Ventilation.
- ③ Off.
- ④ Heating.
- ⑤ Cool.
- ⑥ Warm
- ⑦ If an external temperature sensor is connected, then the wire bridge on the top of the housing must be cut. After that the internal temperature sensor is not in function. It is not possible to reset the system.

● Fonction avec le thermostat d'ambiance électronique.

Fonctionnement:

- Mise en service "ventilation" avec l'interrupteur de thermostat d'ambiance.
- Mise en service "chauffage" avec l'interrupteur de thermostat d'ambiance: illimitée (chauffage permanent).
- Le thermostat d'ambiance commute l'appareil de chauffage de "plein régime" à "régime partiel".
- LED vert dans le thermostat d'ambiance: indicateur de fonctionnement.

- ① R1 seulement pour le régime partiel.
- ② Ventilation.
- ③ Mise hors circuit.
- ④ Chauffage.
- ⑤ Froid.
- ⑥ Chaud.
- ⑦ Lorsqu'une sonde de température externe est reliée, la connexion doit être séparée de boîtier de thermostat. La sonde de température interne n'est pas en fonction. Il n'est pas possible de rappeler le système.

● Funzionamento con termostato ambiente elettronico.

Funzionamento:

- Portare su "ventilazione" azionando l'interruttore del termostato ambiente.
- Portare su "riscaldamento" utilizzando lo stesso interruttore: durata illimitata.
- Durante il riscaldamento l'apparecchio viene regolato tra potenza piena e potenza ridotta ad opera del termostato ambiente.
- LED verde nel termostato ambiente: spia funzionamento.

- ① R1 solo per potenza ridotta.
- ② Ventilazione.
- ③ Spegnimento.
- ④ Riscaldamento.
- ⑤ Freddo.
- ⑥ Caldo.
- ⑦ Se si impiega un termosensore esterno è necessario togliere il ponte sul lato superiore del corpo. In tal modo viene messo fuori servizio il termosensore interno (non è possibile alcun ripristino!).

Legend see page 155.
Functional diagram see page 20.

Légende voir page 155.
Diagramme de fonction voir page 64.

Per leggenda vedere pag. 155.
Per diagramma di funzionam. ved. pag. 108.

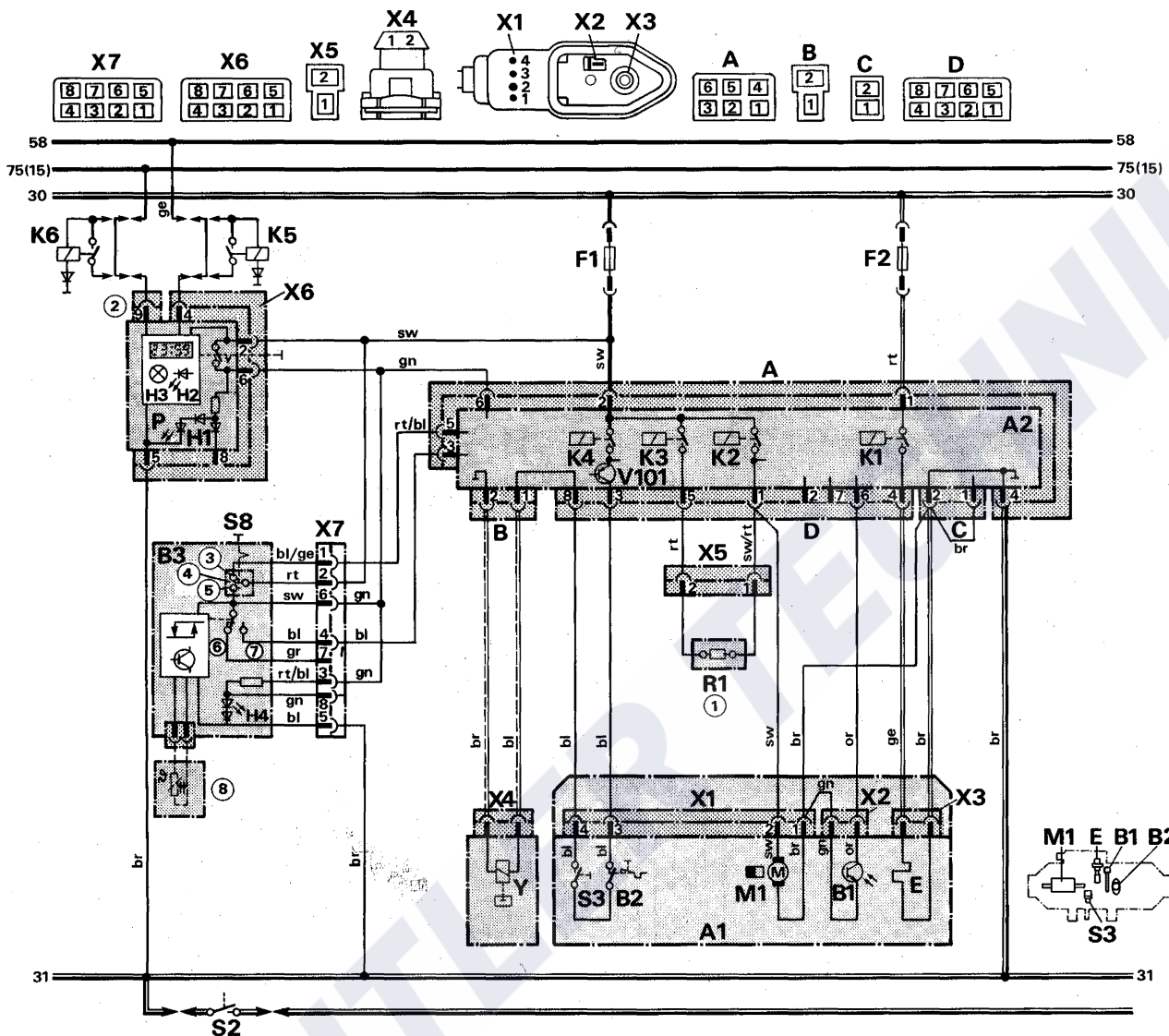

Fig. 13: Automatic control for HL 18 D with part-load operation, 12 and 24 volts, (14887A)

Fig. 13: Branchement automatique pour HL 18 D avec le régime partiel, 12 et 24 volts, (14887A)

Fig. 13: Comando automatico per riscaldatore HL 18 D con potenza ridotta, 12 e 24 Volt, (14887A)

● Operation with digital timer and electronic room thermostat.

● Fonction avec le montre de pré-sélection et le thermostat d'amb. électronique.

● Funzionamento con timer digitale e termostato ambiente elettronico.

Function:

- Switching on "ventilation" with switch in room thermostat.
- Switching on "heater" with digital timer; pre-selection "instant heating" (definite or indefinite).
- Switching on "heater" with switch in room thermostat: indefinite.
- The room thermostat switches the heater from "full heat" to "reduced heat" during heating operation.
- Green LED in digital timer: operation indicator.
- Green LED in room thermostat: operation indicator.

Funktion:

- Mise en service "ventilation" avec l'interrupteur de thermostat d'ambiance.
- Mise en service "chauffage" avec montre de pré-sél.; présélection "chauff. immédiat" (limitée ou illimitée).
- Mise en service "chauffage" avec l'interrupteur de thermostat d'ambiance: illimitée.
- Le thermostat d'ambiance commute l'appareil de chauffage de "plein régime" à "régime partiel".
- LED vert dans la montre de pré-sélection: indicateur de fonctionnement.
- LED vert dans le thermostat d'ambiance: indicateur de fonctionnement

Funzionamento:

- Portare su "ventilazione" azionando l'interruttore del termostato ambiente.
- Portare su "riscaldamento" azionando l'interruttore del timer: durata illimitata.
- Portare su "riscaldamento" con il timer digitale; tipo di preselezione "riscaldamento immediato" (limitato o illimitato).
- Durante il riscaldamento l'apparecchio viene regolato tra potenza piena e potenza ridotta ad opera del termostato ambiente.
- LED verde nel timer digitale: spia funzionamento.
- LED verde nel termostato ambiente: spia funzionamento.

- ① R1 for reduced heat mode only.
- ② Digital timer P:
 - pin 9 is connected to positive: icdefinite operation for "immediate heating";
 - pin 9 is not connected to positive: heating period 1 hour.
- ③ Ventilation
- ④ Off.
- ⑤ Heating.
- ⑥ Cool.
- ⑦ Warm.
- ⑧ If an external temperature sensor is connected, then the wire bridge on the top of the housing must be cut. After that the internal temperature sensor is not in function. It is not possible to reset the system.

- ① R1 seulement pour le régime partiel.
- ② Montre de pré-sélection P:
 - branchement 9 au plus: fonctionnement indéfini pour "mise en service immédiate";
 - sans branchement 9 au plus: chauffage 1 heure.
- ③ Ventilation
- ④ Mise hors circuit.
- ⑤ Chauffage.
- ⑥ Froid.
- ⑦ Chaud.
- ⑧ Lorsqu'une sonde de température externe est reliée, la connexion doit être séparée de boîtier de thermostat. La sonde de température interne n'est pas en fonction. Il n'est pas possible de rappeler le système.

- ① R1 solo per potenza ridotta.
- ② Timer digitale P:
 - positivo su attacco 9: funzionamento con riscaldamento immediato;
 - senza positivo su attacco 9: durata riscaldamento 1 hora.
- ③ Ventilazione
- ④ Spegnimento.
- ⑤ Riscaldamento.
- ⑥ Freddo.
- ⑦ Caldo.
- ⑧ Se si impiega un termosensore esterno è necessario togliere il ponte sul lato superiore del corpo. In tal modo viene messo fuori servizio il termosensore interno (non è possibile alcun ripristino).

Legend see page 155.
Functional diagram see page 20.

Legend voir page 155.
Diagramme de fonction voir page 64.

Per leggenda vedere pag. 155.
Per diagramma di funzionam. ved. ag. 108.

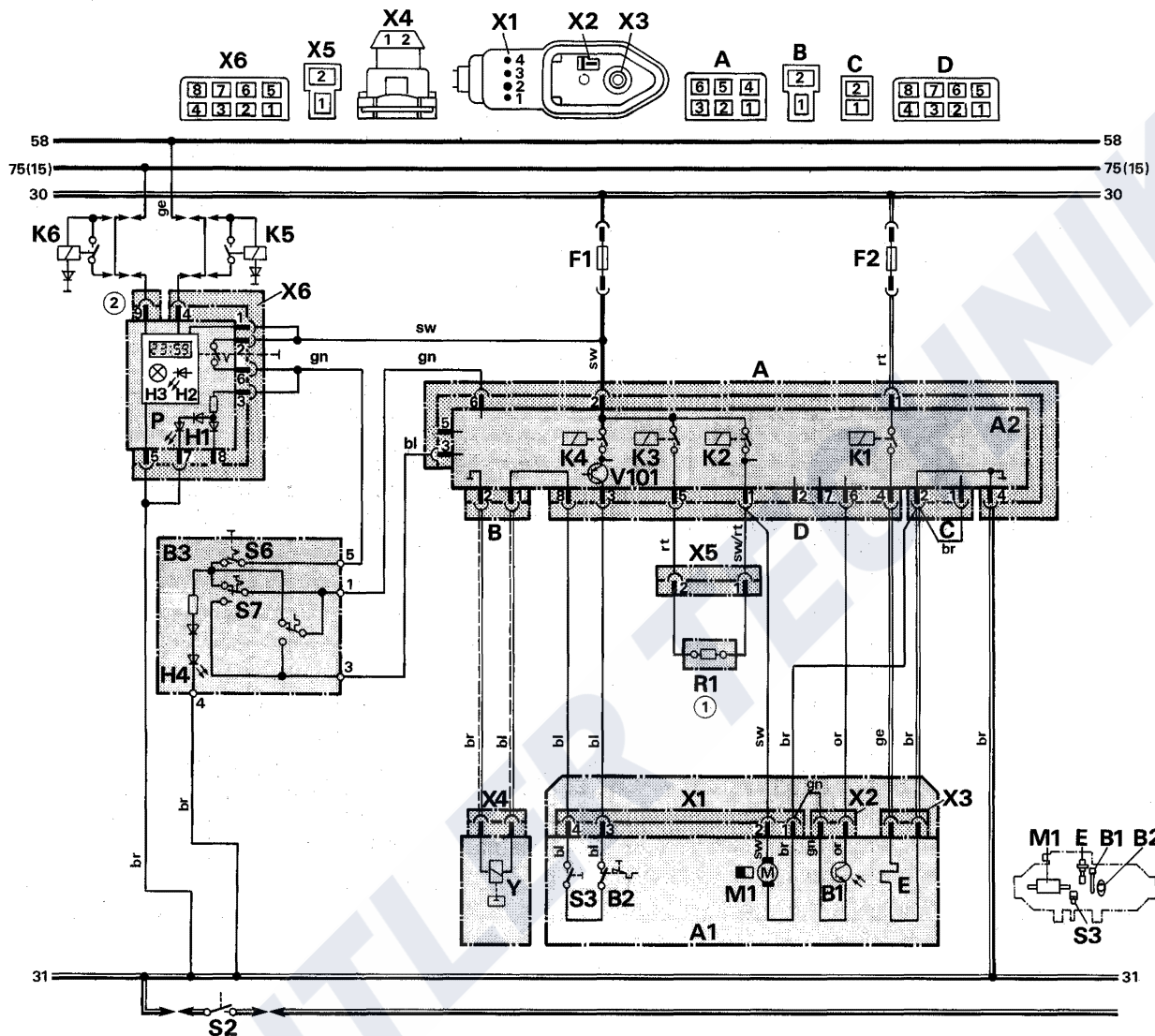

Fig. 14: Automatic control for HL 18 D with part-load operation, 12 and 24 volts, (14885A)

Fig. 14: Branchement automatique pour HL 18 D avec le régime partiel, 12 et 24 volts, (14885A)

Fig. 14: Comando automatico per riscaldatore HL 18 D con potenza ridotta, 12 e 24 Volt, (14885A)

● Operation with digital timer and mechanical room thermostat.

● Fonction avec le montre de pré-sélection et le thermostat d'amb. mécanique.

● Funzionamento con timer digitale e termostato ambiente meccanico.

Function:

- Switching on "heater" with digital timer; pre-selection "immediate heating" (definite or indefinite).
- Requirements: switch S6 in room thermostat is set in position "on"
- The heater is switched from "full heat" to "reduced heat" depends on position of switch, and it is switched off if the rated temperature is reached.
- Green LED in digital timer: operation indicator.

Fonctionnement:

- Mise en service "chauffage" avec montre de pré-sélection; "chauffage immédiat" (limitée ou illimitée). *Supposition: l'interrupteur S6 dans le thermostat d'ambiance est mis en position "marche".*
- L'appareil de chauffage est commuté de "plein régime" à "régime partiel" et il est hors circuit si la température nominale est rattrapée.
- LED vert dans la montre de pré-sélection: indicateur de fonctionnement.

Funzionamento:

- Portare su "riscaldamento" mediante il timer digitale; tipo di preselezione "riscaldamento immediato" (durata limitato o illimitato). *Premessa: portare su "on" l'interruttore S6 del termostato ambiente.*
- Durante il riscaldamento l'apparecchio può essere regolato tra potenza piena e potenza ridotta a seconda della posizione dell'interruttore e si spegne al raggiungimento della temperatura di taratura.
- LED verde nel timer digitale: spia funzionamento.

- ① R1 for reduced heat mode only.
- ② Digital timer P:
 - pin 90 is connected to positive: indefinite operation for "immediate heating";
 - pin 9 is not connected to positive: heating period 1 hour.

- ① R1 seulement pour le régime partiel.
- ② Montre de pré-sélection P:
 - branchement 9 au plus: fonctionnement indéfini pour "mise en service immédiate";
 - sans branchement 9 au plus: chauffage 1 heure.

- ① R1 solo per potenza ridotta.
- ② Timer digitale P:
 - positivo su attacco 9: funzionamento con riscaldamento immediato;
 - senza positivo su attacco 9: durata riscaldamento 1 ora.

Legend see page 155.
Functional diagram see page 20.

Légende voir page 155.
Diagramme de fonction voir page 64.

Per leggenda vedere pag. 155.
Per diagramma di funz. ved. pag. 108.

9 Wiring diagrams • Plans de connexions • Schemi collegamenti elettrici

TRS

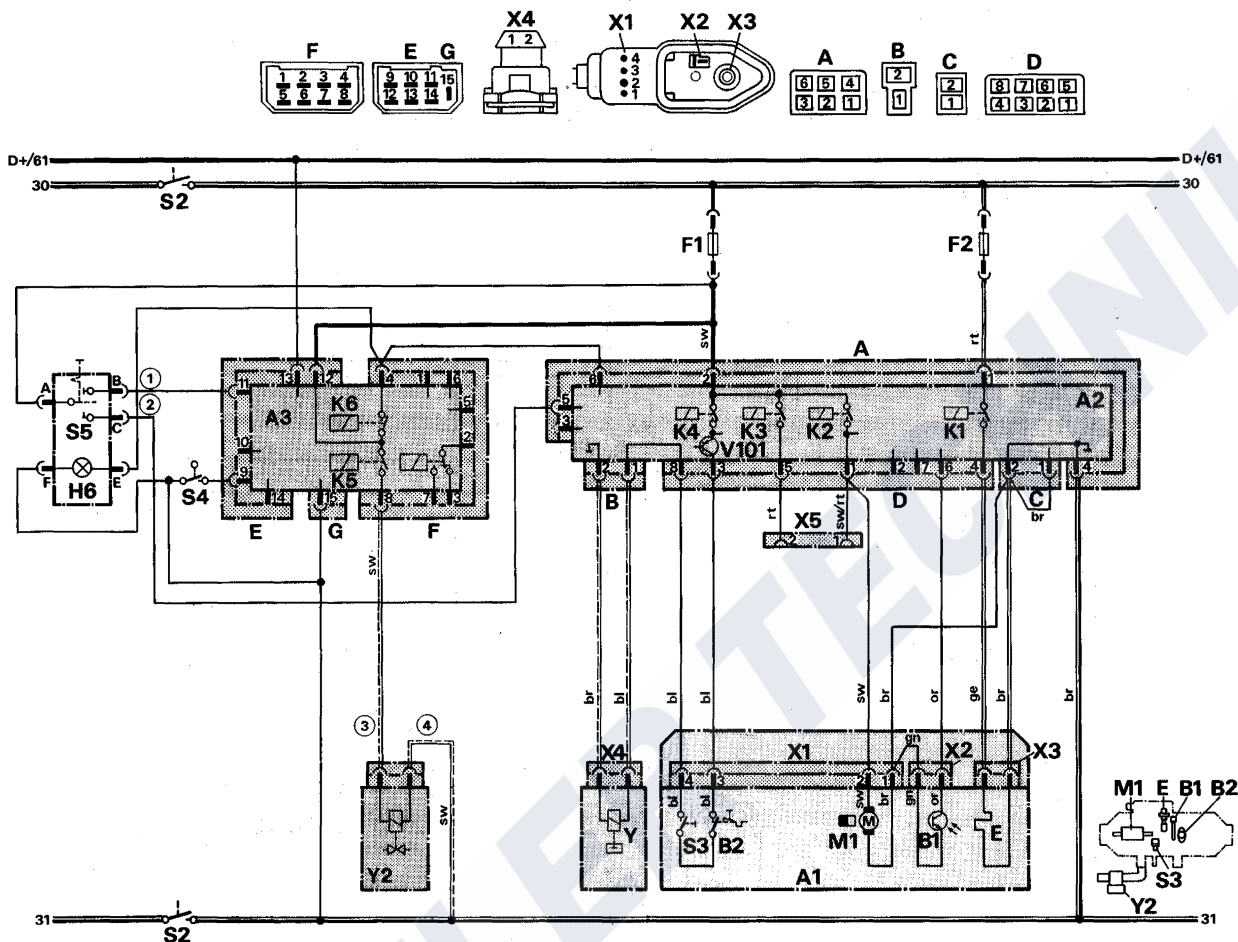

Fig. 15: Automatic control for HL 18 D (TRS), 12 and 24 volts,, (20250A)

Fig. 15: Branchement automatique pour HL 18 D (TRS), 12 et 24 volts, (20250A)

Fig. 15: Comando automatico per HL 18 D (TRS), 12 e 24 Volt, (20250A)

- Operation with switch (without reduced heat).
- for vehicles transporting dangerous goods according to TRS 002 and TRS 003.

- Fonction avec l'interrupteur (sans le régime partiel).
- pour les véhicules au transport de marchandises dangereuses selon TRS 002 et TRS 003.

- Funzionamento con interruttore (senza potenza ridotta).
- per veicoli adibiti al trasporto di materiali pericolosi in conformità alle norme TRS 002 e TRS 003.

○ For the installation of heaters HL 18 D (TRS) in vehicles transporting dangerous goods the instructions of TRS 002 and TRS 003 (technical directions dangerous goods versions) must be observed additionally to the german StVZO. Other instructions see Technical Information E 3 - 5.8 (order no. 770514).

○ Pour le montage des chauffages sur des véhicules de transport de matières dangereuses, les dispositions de TRS 002 et TRS 003 (directives techniques du transport par route de produits dangereux) doivent être observées (pour l'Allemagne). Voir l'Information E3-5.8 (réf. 770514) pour les autres instructions.

○ Per il montaggio su veicoli destinati al trasporto di merci pericolose è ammesso solo il riscaldatore HL 18 D (TRS), che va montato in ottemperanza alle norme TRS 002 e TRS 003 (direttive tecniche per trasporto su strada di materiali pericolosi). Per ulteriori disposizioni si rimanda all'informazione Webasto E3 - 5.8 (cat. nr. 770514).

○ The switch S4 has to be installed in such a manner that it closes the minuscontact, when a delivering device starts its operation.

○ Le commutateur S4 doit être installé de telle sorte, qu'il ferme son contact à pôle négatif lors de la mise en service d'un dispositif d'acheminement.

○ L'interruttore S4 deve essere installato in modo che il suo contatto negativo venga chiuso, quando viene messa in funzione un dispositivo di alimentazione.

- ① Heating.
- ② Ventilation.
- ③ Cable 1.
- ④ Cable 2.

- ① Chauffage.
- ② Ventilation.
- ③ Câble 1.
- ④ Câble 2.

- ① Riscaldamento.
- ② Ventilazione..
- ③ Cavi 1.
- ④ Cavi 2.

Legend see page 155.
Functional diagram see page 20.

Légende voir la page 155.
Diagramme de fonction voir page 64.

Per leggenda vedere pag. 155.
Per diagramma di funzion. ved. pag. 108.

9 Wiring diagrams • Plans de connexions • Schemi collegamenti elettrici

Item Rep. Pos.	Description Désignation Denominazione	Remarks Remarques Specificazioni
A1	Heater Appareil de chauffage Riscaldatore	HL 18 B/D or HL 18 D (TRS) HL 18 B/D ou HL 18 D (TRS) HL 18 B/D o HL 18 D (TRS)
A2	Control unit Boîtier de commande Centralina	SG 1561-GT TRS with Integral Glow Pulsing SG 1561-GT TRS avec cadence de combustion intégrée SG 1561-GT TRS con comando ad impulsi integrato
A3	Control unit TRS/ADR Boîtier de commande TRS/TMD Centralina TRS	SG 1547
B1	Flame detector Contrôleur de flamme Fotoresistenza	ensure correct polarity polarité importante fare attenzione alla polarità
B2	Thermostat Thermostat Termostato	Overheat Limiteur de température Termostatore
B3	Thermostat Thermostat Termostato	Room thermostat Thermostat d'ambiance Termostato ambiente
E	Glow Plug Bougie à incandescence Candela	
F1	Fuse 5A Fusible 5A Fusibile 5A	plate fuse SAE J 1284 fusibile plate SAE J 1284 fusibile piatto SAE J 1284
F2	Fuse 25A Fusible 25A Fusibile 25A	plate fuse SAE J 1284 fusibile plate SAE J 1284 fusibile piatto SAE J 1284
H1	Green LED Voyant vert LED verde	Operation indicator (in item P) Témoin de fonction (dans rep. P) spia funzionamento (in pos. P)
H2	Yellow LED Voyant jaune LED giallo	program ready light (in item P) pré-selection (dans rep. P) spia preselez. attivata (in Pos. P)
H3	Lamps Voyants Lampada	symbol lighting (in item P) éclairage (dans rep. P) illuminazione simboli (in pos. P)
H4	Green LED Voyant vert LED verde	Operation indicator (in item B3) Témoin de fonction (dans rep. B3) spia funzionamento (in pos. B3)
H6	Green light Voyant vert Lampada verde	Operation indicator (in item S5) Témoin de fonction (dans rep. S5) spia funzionamento (in pos. S5)
K1	Relay (in item A2) Relais (dans rep. A2) Relè (in pos. A2)	for glow plug pour incandescence per incandescenza
K2	Relay Relais Relè	(in item A2) (dans rep. A2) (in pos. A2)
K3	Relay Relais Relè	(in item A2) (dans rep. A2) (in pos. A2)
K4	Relay Relais Relè	(in item A2) (dans rep. A2) (in pos. A2)
K5	Relay Relais Relè	only needed with battery isolation switch on negative pole seulement pour montage avec coupe batterie dans (-) necessari solo con interruttore batteria nel (-)
K6	Relay Relais Relè	
M1	Motor Moteur Motore	combustion air fan turbine d'air de combustion ventilatore aria comburente
P	Digital timer Montre de pré-sélection Timer digitale	for programmed operation affichage digital per funzionamento con preselezione

Item Rep. Pos.	Description Désignation Denominazione	Remarks Remarques Specificazioni
R1	Resistance for reduced heat Résistance de régime partiel Resistenza (potenza ridotta)	resistance to M1 résistance à M1 supplementare per M1
S2	Switch Commutateur Interruttore	battery switch robinet de batterie interruttore batteria
S3	Switch Commutateur Interruttore	safety switch commutateur de sécurité interruptore di sicurezza
S4	Switch Commutateur Interruttore	Na+/Na- TRS or Switch on delivering device Na+/Na- TRS ou Commutateur on delivering device Na+/Na- TRS o interruttore nella apparecchiatura di alimentazione
S5	Switch Commutateur Interruttore	heating / off / ventilation chauffage / arrêt / ventilation riscaldamento / spegnim. / ventilation
S5	Switch Commutateur Interruttore	ventilat. / off / full heat / reduced heat ventilat. / arrêt / plein rég. / rég. partiel ventilat. / spegnim. / pot. pleine / pot. ridotta
S6	Switch Commutateur Interruttore	on / off marche / arrêt riscaldamento / spegnimento
S7	Switch Commutateur Interruttore	full/reduced heat, reduced heat/off plein/part. régime, régime part./arrêt pot. pleine/pot. ridotta, pot. ridotta/spegnim.
S8	Switch Commutateur Interruttore (in item B3) (dans rep. B3) (in pos. B3)	ventilation / off / heating ventilation / arrêt / chauffage ventilation / spegnim. / riscaldamento
V16	Diode Diode Diodo	
V17	Diode Diode Diodo	
V101	Transistor Transistor Transistor	in item A2 dans rep. A2 in pos. A2
X1	Connector Raccordement Collegamento	4 poles 4 pôles a spina 4 poli
X2	Connector Raccordement Collegamento	2 poles 2 pôles a spina bipolare
X3	Connector Raccordement Collegamento	2 poles 2 pôles a spina bipolare
X4	Connector Raccordement Collegamento	2 poles 2 pôles a spina bipolare
X5	Connector Raccordement Collegamento	2 poles 2 pôles a spina bipolare
X6	Connector Raccordement Collegamento	8 poles 8 pôles a spina 8 poli
X7	Connector Raccordement Collegamento	1 pole 1 pôle a spina unipolare
X7	Connector Raccordement Collegamento	8 poles 8 pôles a spina 8 poli
X8	Connector Raccordement Collegamento	8 poles 8 pôles a spina 8 poli
Y	Dosing pump Pompe doseur Pompa dosatrice	
Y2	Solenoid valve TRS or Solenoid with reduced consumption Electrovanne TRS ou Electrovanne avec réduction de consommation Valvola magnetica trs rps. vazvola magnetica con oimnuzione di potenza	for Combustion Air Pipe pour Conduite d'air de combustion combustione aria comburente

Wire colours Couleurs des câbles Colori dei cavi			
bl	blue	bleu	blu
br	brown	brun	marrone
ge	yellow	jaune	giallo
gn	green	vert	verde
gr	gray	gris	grigio
or	orange	orange	aranc.
rt	red	rouge	rosso
sw	black	noir	nero
vi	violet	violet	violetto
ws	white	blanc	bianco

Wire Ganges Sections des conducteurs Sezioni dei cavi		
	< 7,5m	7,5 - 15m
	0,75mm ²	1,5mm ²
	1,0mm ²	1,5mm ²
	1,5mm ²	2,5mm ²
	2,5mm ²	4,0mm ²
	4,0mm ²	6,0mm ²

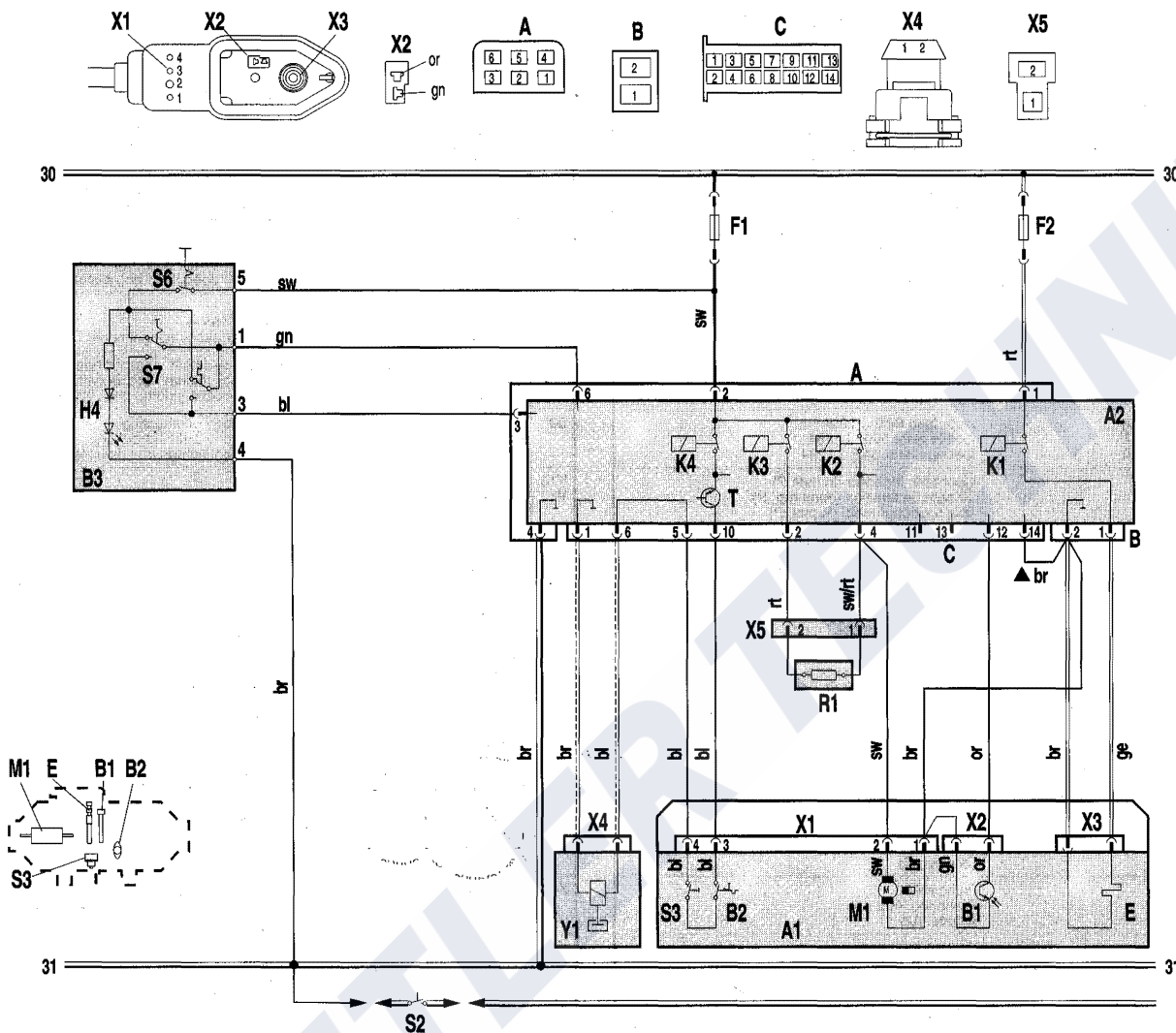

Fig. 16: Automatic control for Air Top 18, 12 and 24 volts

Fig. 16: Branchement automatique pour Air Top 18, 12 et 24 volts

Fig. 16: Comando automatico per riscaldatore Ait Top 18, 12 e 24 Volt

▲ For petrol heater, remove this connection.

▲ Pour chauffage à essence supprimer ce branchement.

▲ Rimuovere questo attacco per gli apparecchi a benzina.

Operation with mechanical room thermostat.

Fonction avec le thermostat d'ambiance mécanique.

Funzionamento con termostato ambiente meccanico.

Legend see page 157.

Légende voir les pages 157.

Per leggenda vedere pag. 157.

Wire Ganges Sections des conducteurs Sezioni dei cavi	
	< 7,5m
	7,5 - 15m
	0,75mm ²
	1,5mm ²
	1,0mm ²
	1,5mm ²
	2,5mm ²
	4,0mm ²
	6,0mm ²

Wire colours Couleurs des câbles Colori dei cavi			
bl	blue	bleu	blu
br	brown	brun	marrone
ge	yellow	jaune	giallo
gn	green	vert	verde
gr	gray	gris	grigio
or	orange	orange	aranc.
rt	red	rouge	rosso
sw	black	noir	nero
vi	violet	violet	violetto
ws	white	blanc	bianco

9 Wiring diagrams • Plans de connexions • Schemi collegamenti elettrici

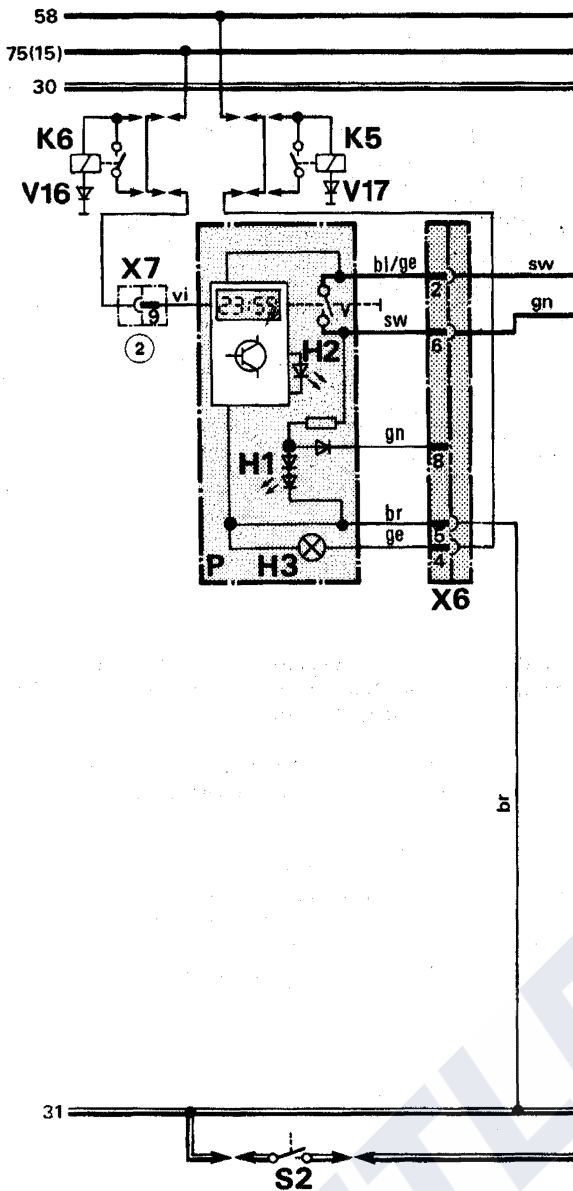

Fig. 17: Example for application only required if battery switch connected to negative (-)

Fig. 17: exemple d'utilisation nécessité seulement lorsque le disjoncteur de batterie est sur pole négatif (-)

Fig. 17: esempio di applicazione necessario solo a interruttore d. batteria su negativo (-)

Item Rep. Pos.	Description Désignation Denominazione	Remarks Remarques Specificazioni
H1	Green LED Voyant vert LED verde	Operation indicator (in item P) Témoin de fonction (dans rep. P) spia funzionamento (in pos. P)
H2	Yellow LED Voyant jaune LED giallo	program ready light (in item P) pré-sélection (dans rep. P) spia preselez. attivata (in pos. P)
H3	Lamps Voyants Lampada	symbol lighting (in item P) éclairage (dans rep. P) illuminazione simboli (in pos. P)
H4	Green LED Voyant vert LED verde	Operation indicator (in item B3) Témoin de fonction (dans rep. B3) spia funzionamento (in pos. B3)
K1	Relay (in item A2) Relais (dans rep. A2) Relè (in pos. A2)	for glow plug pour incandescence per incandescenza
K2	Relay (in item A2) Relais (dans rep. A2) Relè (in pos. A2)	
K3	Relay (in item A2) Relais (dans rep. A2) Relè (in pos. A2)	
K4	Relay (in item A2) Relais (dans rep. A2) Relè (in pos. A2)	
K5	Relay	only needed with battery isolation switch on negative pole seulement pour montage avec coupe batterie dans (-) necessari solo con interruttore batteria nel (-)
K6	Relay	
M1	Motor Moteur Motore	combustion air fan turbine d'air de combustion ventilatore aria comburente
P	Digital timer Montre de pré-sélection Timer digitale	for programmed operation affichage digital per funzionamento con preselezione
R1	Resistance for reduced heat Résistance de régime partiel Resistenza (potenza ridotta)	resistance to M1 résistance à M1 supplementare per M1
S2	Switch Commutateur Interruttore	battery switch robinet de batterie staccabatteria
S3	Switch Commutateur Interruttore	safety switch commutateur de sécurité interruttore di sicurezza
S6	Switch Commutateur Interruttore	on / off marche / arrêt riscaldamento / spegnimento
S7	Switch Commutateur Interruttore	full/reduced heat, reduced heat/off plein/part. régime, régime part./arrêt pot. piena/pot. ridotta, pot. ridotta/spegnim.
S8	Switch (in item B3) Commutateur (dans rep. B3) Interruttore (in pos. B3)	ventilation / off / heating ventilation / arrêt / chauffage ventilation / spegnim. / riscaldamento
V16	Diode	
V17	Diode	
V101	Transistor Transistor Transistore	in item A2 dans rep. A2 in pos. A2
X1	Connector Raccordement Collegamento	4 poles 4 pôles a spina 4 poli
X2	Connector Raccordement Collegamento	2 poles 2 pôles a spina bipolare
X3	Connector Raccordement Collegamento	2 poles 2 pôles a spina bipolare
X4	Connector Raccordement Collegamento	2 poles 2 pôles a spina bipolare
X5	Connector Raccordement Collegamento	2 poles 2 pôles a spina bipolare
X6	Connector Raccordement Collegamento	8 poles 8 pôles a spina 8 poli
X7	Connector Raccordement Collegamento	1 pole 1 pôle a spina unipolare
Y	Dosing pump Pompe doseur Pompa dosatrice	

Item Rep. Pos.	Description Désignation Denominazione	Remarks Remarques Specificazioni
A1	Heater Appareil de chauffage Riscaldatore	Air Top 18
A2	Control unit Boîtier de commande Centralina	SG 1561-GS
B1	Flame detector Contrôleur de flamme Fotoresistenza	ensure correct polarity polarité importante fare attenzione alla polarità
B2	Thermostat Thermostat Termostato	Overheat Limiteur de température Termolimitatore
B3	Thermostat Thermostat Termostato	Room thermostat Thermostat d'ambiance Termostato ambiente
E	Glow Plug Bougie à Incandescence Candela	
F1	Fuse 5A Fusible 5A Fusibile 5A	plate fuse SAE J 1284 fusible plate SAE J 1284 fusibile piatto SAE J 1284
F2	Fuse 25A Fusible 25A Fusibile 25A	plate fuse SAE J 1284 fusible plate SAE J 1284 fusibile piatto SAE J 1284

9 Wiring diagrams • Plans de connexions • Schemi collegamenti elettrici

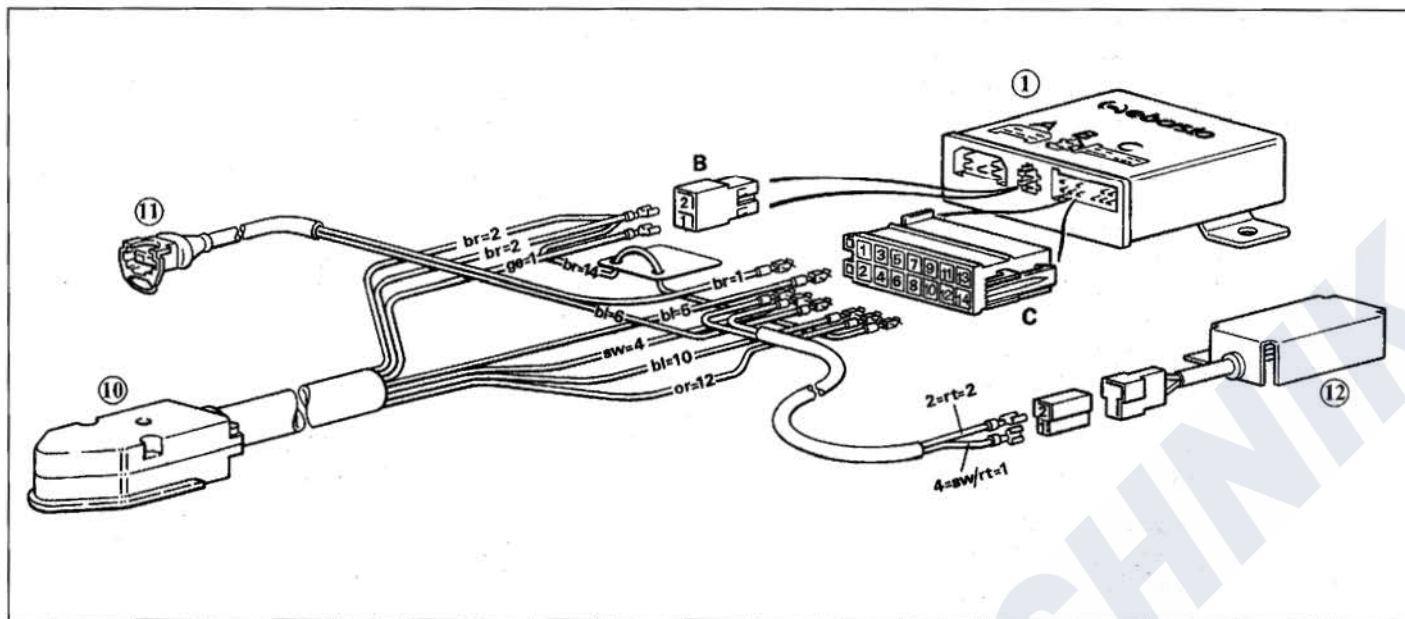

Fig. 18: Example for application in connection with automatic control wiring diagram Fig. 15 for Air Top 18

Fig. 18: exemple d'utilisation en rapport avec le schéma de connexion automatique, fig. 15 pour Air Top 18

Fig. 18: esempio di applicazione in collegamento con schema automatismi fig. 15 per Air Top 18

Connection control unit / part load resistor / heater metering pump

connexion organe de commande / résistance de régime partiel / appareil de chauffage / pompe de dosage

Collegamento centralina / resistenza p. potenza ridotta / riscaldatore / pompa di dosatrice

- 1 Control unit
- 10 Plug connection, heater
- 11 Plug connection, metering pump
- 12 Part-load resistor

- 1 organe de commande
- 10 connecteur à fiches appareil de chauffage
- 11 connecteur à fiches pompe de dosage
- 12 résistance de régime partiel

- 1 Centralina
- 10 Collegamento a spina riscaldatore
- 11 Collegamento a spina pompa di dosatrice
- 12 Resistenza per potenza ridotta

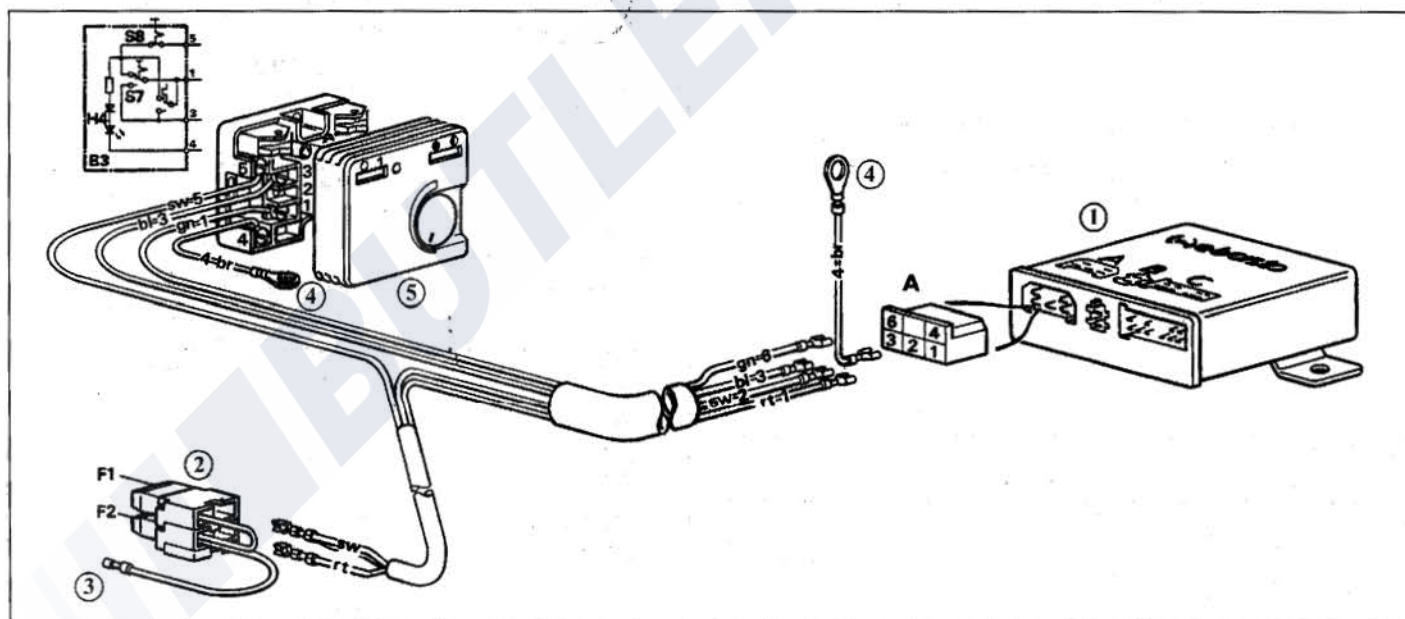

Fig. 19: Example for application in connection with automatic control wiring diagram Fig. 15 for Air Top 18

Fig. 19: exemple d'utilisation en rapport avec le schéma de connexion automatique, fig. 15 pour Air Top 18

Fig. 19: esempio di applicazione in collegamento con schema automatismi fig. 15 per Air Top 18

Connection control unit / fuse holder / room thermostat (mechanical)

connexion organe de commande / porte-fusibles / thermostat ambiant (mécanique)

Collegamento centralina / portafusibili / termostato ambiente (meccanico)

- 1 Control unit
- 2 Fuse holder
- 3 To battery (+)
- 4 Ground (-)
- 5 Interior-temperature thermostat (mechanical)

- 1 organe de commande
- 2 porte-fusibles
- 3 vers la batterie (+)
- 4 la masse (-)
- 5 thermostat ambiant (mécanique)

- 1 Centralina
- 2 Portafusibili
- 3 alla batteria (+)
- 4 Massa (-)
- 5 Termostato ambiente (meccanico)

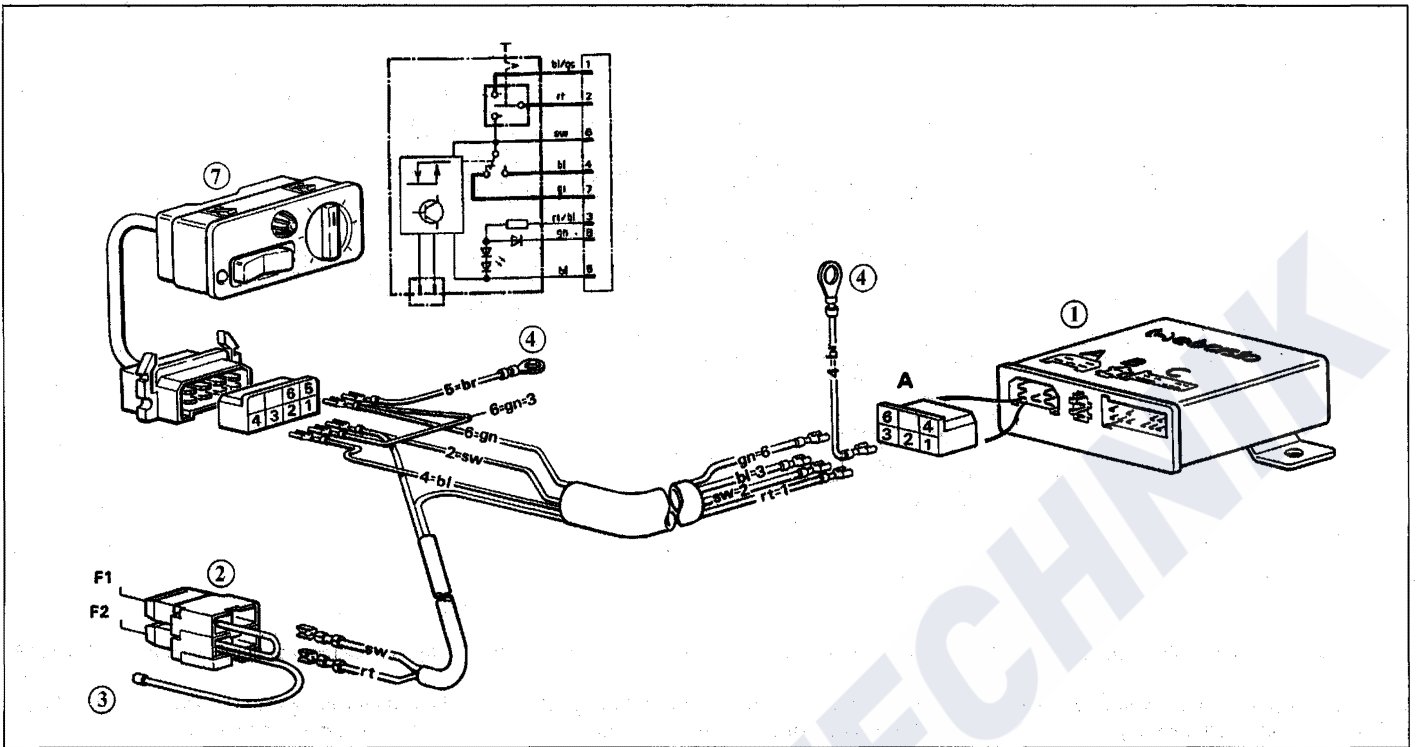

Fig. 20: Example for application in connection with automatic control wiring diagram Fig. 15 for Air Top 18

Connection control unit / fuse holder / room thermostat (electronic)

- 1 Control unit
- 2 Fuse holder
- 3 To battery (+)
- 4 Ground (-)
- 5 Interior-temperature thermostat (electronic)

Fig. 20: exemple d'utilisation en rapport avec le schéma de connexion automatique, fig. 15 pour Air Top 18

connexion organe de commande/porte-fusibles/thermostat ambiant (électronique)

- 1 organe de commande
- 2 porte-fusibles
- 3 vers la batterie (+)
- 4 la masse (-)
- 5 thermostat ambiant (électronique)

Fig. 20: esempio di applicazione in collegamento con schema automatismi fig. 15 per Air Top 18

Collegamento centralina/portafusibili/termostato ambiente (elettronico)

- 1 Centralina
- 2 Portafusibili
- 3 alla batteria (+)
- 4 Massa (-)
- 5 Termostato ambiente (elettronico)

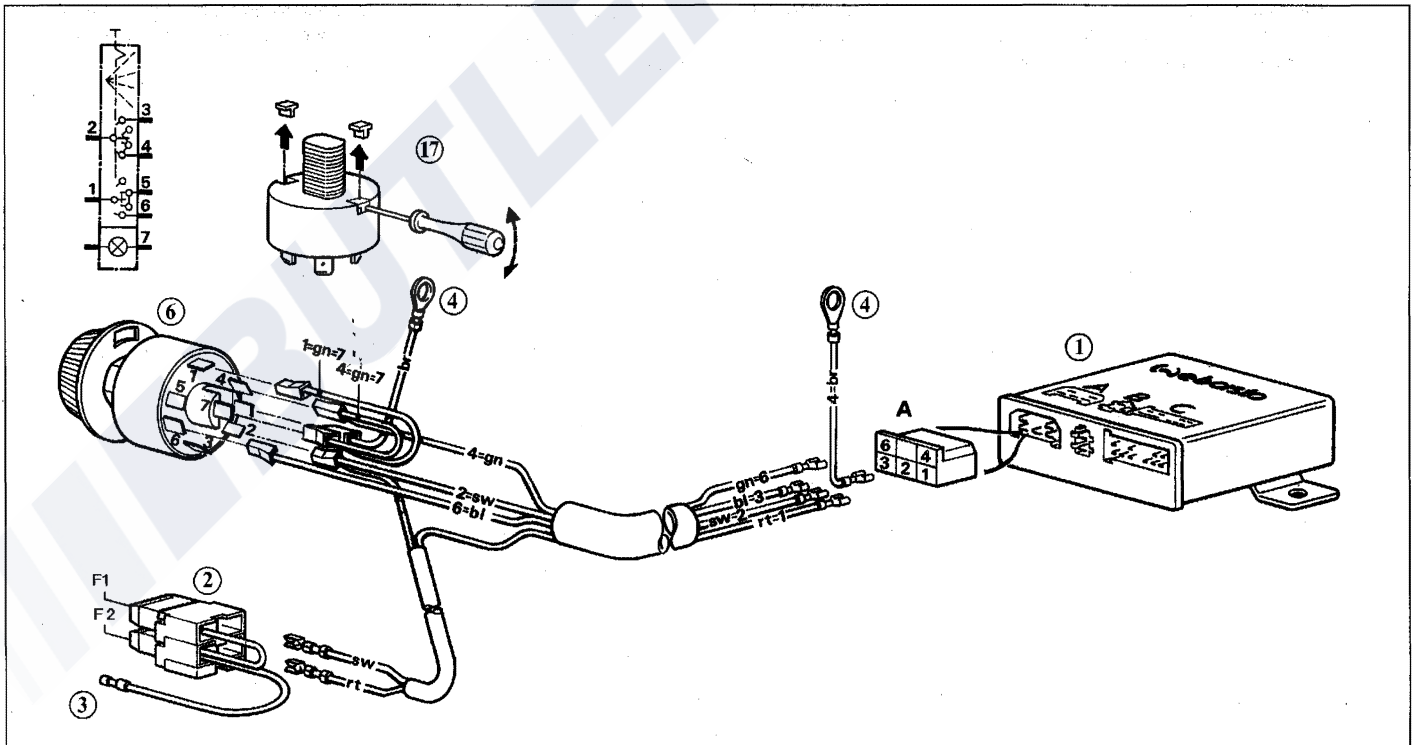

Fig. 21: Example for application in connection with automatic control wiring diagram Fig. 15 for Air Top 18

Connection control unit / fuse holder / switch

- 1 Control unit
- 2 Fuse holder
- 3 To battery (+)
- 4 Ground (-)
- 6 Switch
- 17 Remove the two white retention pins

Fig. 21: exemple d'utilisation en rapport avec le schéma de connexion automatique, fig. 15 pour Air Top 18

connexion organe de commande/porte-fusibles/commutateur

- 1 organe de commande
- 2 porte-fusibles
- 3 vers la batterie (+)
- 4 la masse (-)
- 6 commutateur
- 17 Enlever les 2 goupilles blanches

Fig. 21: esempio di applicazione in collegamento con schema automatismi fig. per 15 Air Top 18

Collegamento centralina/portafusibili/interruttore

- 1 Centralina
- 2 Portafusibili
- 3 alla batteria (+)
- 4 Massa (-)
- 6 Interruttore
- 17 Rimuovere i due perni bianchi

9 Wiring diagrams • Plans de connexions • Schemi collegamenti elettrici

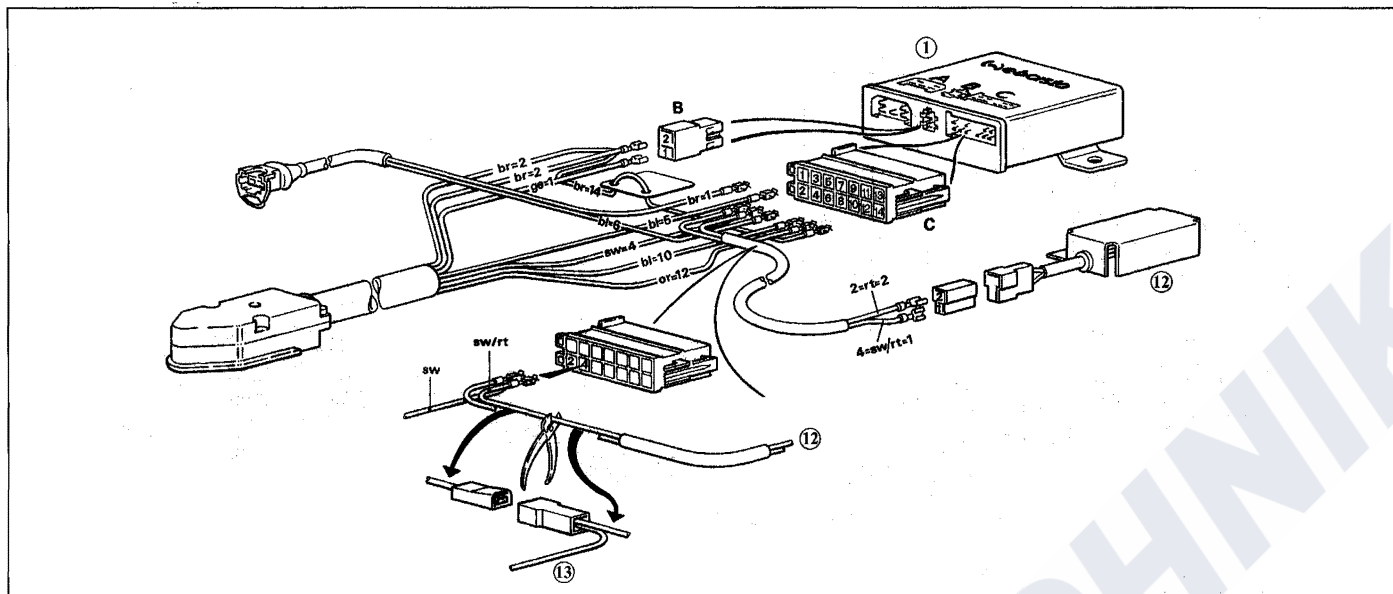

Fig. 22: Example for application for Air Top 18

Ventilation operation by means of switch or room thermostat (electronic)

- Disconnect line bk/rd as shown in figure and establish line connection to switch, contact 3, or room thermostat (electronic), contact 1.

- 1 Control unit
- 12 Part-load resistor
- 13 Line connection of switch or room thermostat (electronic).
wire color rd/bu to be used owing to the danger of interchanging wires

Fig. 22: exemple d'utilisation pour Air Top 18

aération à l'aide du commutateur ou du thermostat ambiant (électronique)

- déconnecter le conducteur noir/rouge et réaliser une liaison au commutateur, contact 3, ou au thermostat ambiant (électronique), contact 1

- 1 organe de commande
- 12 résistance de régime partiel
- 13 connecteur commutateur ou thermostat ambiant (électronique).
utiliser des conducteurs de couleur rouge/bleu pour éviter toute confusion

Fig. 22: esempio di applicazione per Air Top 18

Funzionamento a ventilazione con interruttore o termostato ambiente (elettronico)

- separare circuito nero/rosso secondo raffigurazione e instaurare collegamento all'interruttore contatto 3 o al termostato ambiente (elettronico) contatto 1

- 1 Centralina
- 12 Resistenza per potenza ridotta
- 13 Collegamento circuito interruttore o termostato ambiente (meccanico):
causa pericolo di scambio usare rosso/ blu

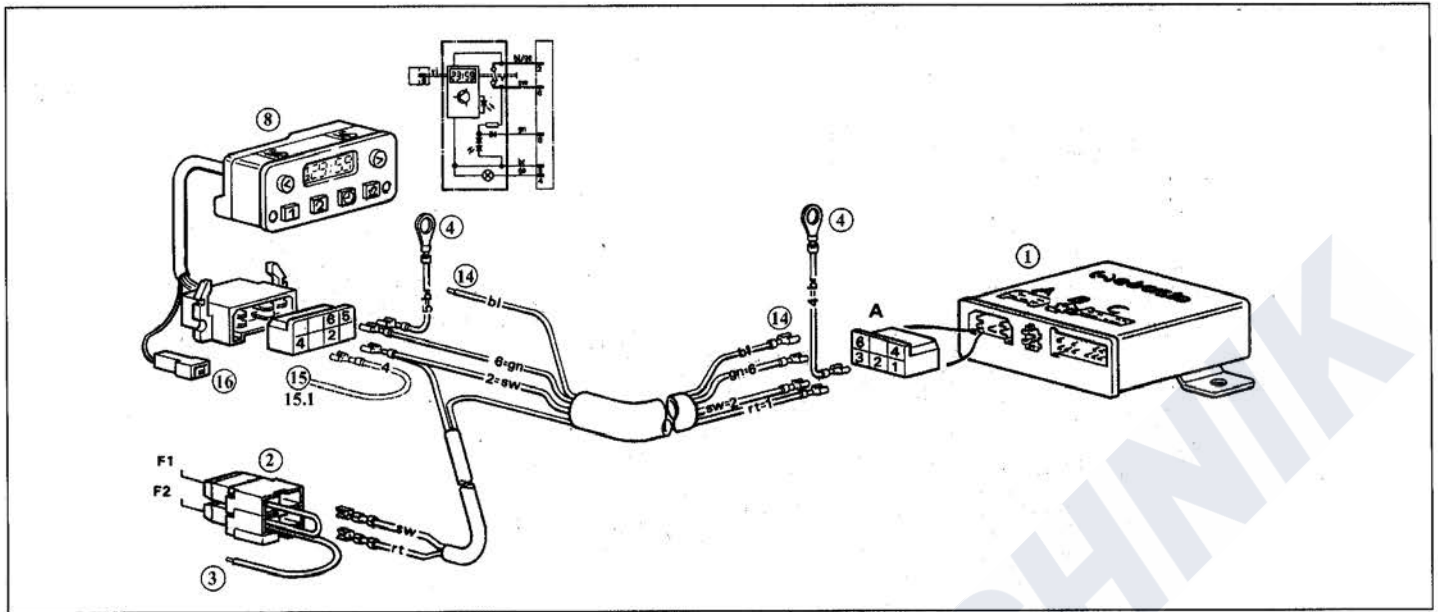

Fig. 23: Example for application in connection with automatic control wiring diagram Fig. 15 for Air Top 18

Fig. 23: exemple d'utilisation en rapport avec le schéma de connexion automatique, fig. 15 pour Air Top 18

Fig. 23: esempio di applicazione in collegamento con schema automatici fig. 15 per Air Top 18

Connection control unit / fuse holder / Timer 1522 (24 hours)

connexion organe de commande/porte-fusibles/minuterie de présélection 1522 (24 heures)

Collegamento centralina/portafusibili/timer digitale 1522 (24 ore)

- 1 Control unit
- 2 Fuse holder
- 3 To battery (+)
- 4 Ground (-)
- 8 Timer 1522 (24 hrs.)
- 14 Not used
- 15 Lighting (terminal 58)
- 15.1 If battery switch is connected to the negative (-) side, see example for application on page 63
- 16 If positive pole of terminal (75/15) is connected to terminal 9: continuous operation in "instant heat" mode as long as ignition is on. If positive pole of terminal (30) is connected to terminal 9: continuous operation in the "instant heat" mode. If positive pole is not connected to terminal 9: heating duration 1 hour.

- 1 organe de commande
- 2 porte-fusibles
- 3 vers la batterie (+)
- 4 la masse (-)
- 8 minuterie de présélection 1522 (24 h)
- 14 vierge
- 15 éclairage (borne 58)
- 15.1 disjoncteur de batterie sur pôle négatif: se référer à exemple d'utilisation page 63
- 16 côté positif de la borne (75/15) sur raccord 9: service continu lors du chauffage immédiat tant que l'allumage est amorcé côté positif de la borne (30) sur raccord 9: service continu lors du chauffage immédiat sans pôle positif sur raccord 9: durée de chauffage: 1 heure

- 1 Centralina
- 2 Portafusibili
- 3 alla batteria (+)
- 4 Massa (-)
- 8 Timer digitale 1522 (24 ore)
- 14 non occupato
- 15 Illuminazione (morsetto 58)
- 15.1 con interruttore d. batteria su negativo vedi esempio di applicazione pag. 63
- 16 con positivo d. morsetto (75/15) al collegamento 9: ciclo continuo a riscaldamento immediato finché accensione accesa con positivo d. morsetto (30) al collegamento 9: funzionamento continuo a riscaldamento immediato senza positivo al collegamento 9: ciclo di riscaldamento per 1 ora

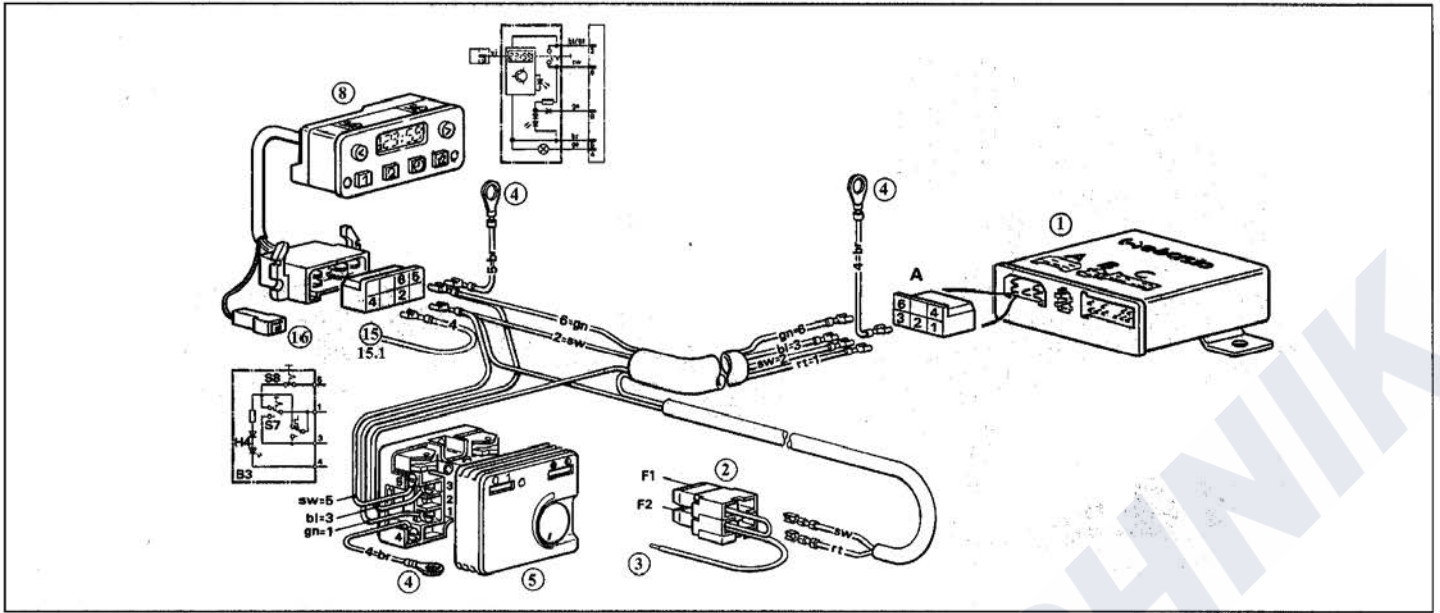

Fig. 24: Example for application in connection with automatic control wiring diagram Fig. 15 for Air Top 18

Fig. 24: exemple d'utilisation en rapport avec le schéma de connexion automatique, fig. 15 pour Air Top 18

Fig. 24: esempio di applicazione in collegamento con schema automatismi fig. 15 per Air Top 18

Connection control unit / fuse holder / room thermostat (mechanical) / Timer 1522 (24 hours)

connexion organe de commande/porte-fusibles/thermostat ambiant (mécanique)/minuterie de présélection 1522 (24 heures)

Collegamento centralina/portafusibili/termostato ambiente (meccanico)/timer digitale 1522 (24 ore)

- 1 Control unit
- 2 Fuse holder
- 3 To battery (+)
- 4 Ground (-)
- 5 Interior-temperature thermostat (mechanical)
- 8 Timer 1522 (24 hrs.)
- 14 Not used
- 15 Lighting (terminal 58)
- 15.1 If battery switch is connected to the negative (-) side, see example for application on page 63
- 16 If positive pole of terminal (75/15) is connected to terminal 9: continuous operation in "instant heat" mode as long as ignition is on. If positive pole of terminal (30) is connected to terminal 9: continuous operation in the "instant heat" mode. If positive pole is not connected to terminal 9: heating duration 1 hour.

- 1 organe de commande
- 2 porte-fusibles
- 3 vers la batterie (+)
- 4 la masse (-)
- 5 thermostat ambiant (mécanique)
- 8 minuterie de présélection 1522 (24 h)
- 14 vierge
- 15 éclairage (borne 58)
- 15.1 disjoncteur de batterie sur pôle négatif: se référer à exemple d'utilisation page 63
- 16 côté positif de la borne (75/15) sur raccord 9: service continu lors du chauffage immédiat tant que l'allumage est amorcé côté positif de la borne (30) sur raccord 9: service continu lors du chauffage immédiat sans pôle positif sur raccord 9: durée de chauffage: 1 heure

- 1 Centralina
- 2 Portafusibili
- 3 alla batteria (+)
- 4 Massa (-)
- 5 Termostato ambiente (meccanico)
- 8 Timer digitale 1522 (24 ore)
- 14 non occupato
- 15 Illuminazione (morsetto 58)
- 15.1 con interruttore d. batteria su negativo vedi esempio di applicazione pag. 63
- 16 con positivo d. morsetto (75/15) al collegamento 9: ciclo continuo a riscaldamento immediato finché accensione accesa con positivo d. morsetto (30) al collegamento 9: funzionamento continuo a riscaldamento immediato senza positivo al collegamento 9: ciclo di riscaldamento per 1 ora

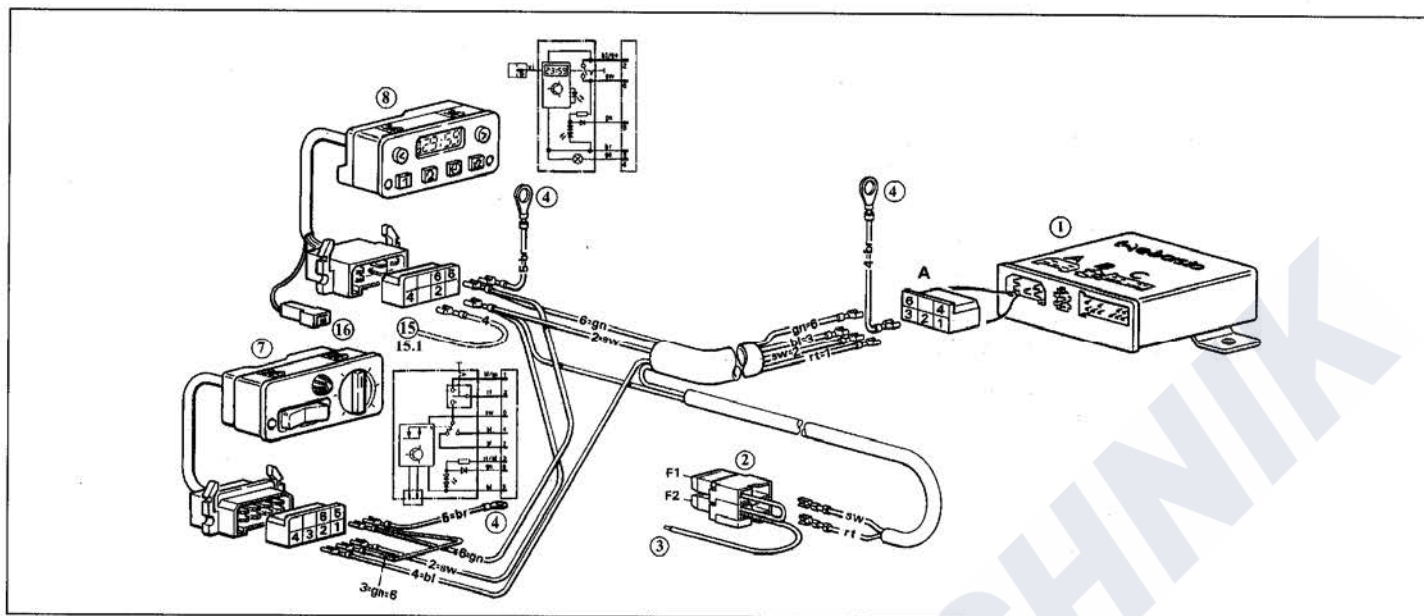

Fig. 25: Example for application in connection with automatic control wiring diagram Fig. 15 for Air Top 18

Fig. 25: exemple d'utilisation en rapport avec le schéma de connexion automatique, fig. 15 pour Air Top 18

Fig. 25: esempio di applicazione in collegamento con schema automatismi fig. 15 per Air Top 18

Connection control unit / fuse holder / room thermostat (electronic) / Timer 1522 (24 hours)

connexion organe de commande/porte-fusibles/thermostat ambiant (électronique)/minuterie de présélection 1522 (24 heures)

Collegamento centralina/portafusibili/termostato ambiente (elettronico)/timer digitale 1522 (24 ore)

- 1 Control unit
- 2 Fuse holder
- 3 To battery (+)
- 4 Ground (-)
- 7 Interior-temperature thermostat (electronic)
- 8 Timer 1522 (24 hrs.)
- 14 Not used
- 15 Lighting (terminal 58)
- 15.1 If battery switch is connected to the negative (-) side, see example for application on page 63
- 16 If positive pole of terminal (75/15) is connected to terminal 9: continuous operation in "instant heat" mode as long as ignition is on. If positive pole of terminal (30) is connected to terminal 9: continuous operation in the "instant heat" mode. If positive pole is not connected to terminal 9: heating duration 1 hour.

- 1 organe de commande
- 2 porte-fusibles
- 3 vers la batterie (+)
- 4 la masse (-)
- 7 thermostat ambiant (électronique)
- 8 minuterie de présélection 1522 (24 h)
- 14 vierge
- 15 éclairage (borne 58)
- 15.1 disjoncteur de batterie sur pôle négatif: se référer à exemple d'utilisation page 130
- 16 côté positif de la borne (75/15) sur raccord 9: service continu lors du chauffage immédiat tant que l'allumage est amorcé côté positif de la borne (30) sur raccord 9: service continu lors du chauffage immédiat sans pôle positif sur raccord 9: durée de chauffage: 1 heure

- 1 Centralina
- 2 Portafusibili
- 3 alla batteria (+)
- 4 Massa (-)
- 7 Termostato ambiente (elettronico)
- 8 Timer digitale 1522 (24 ore)
- 14 non occupato
- 15 Illuminazione (morsetto 58)
- 15.1 con interruttore di batteria su negativo vedi esempio di applicazione pag. 63 con positivo di morsetto (75/15) al collegamento 9: ciclo continuo a riscaldamento immediato finché accensione accesa con positivo di morsetto (30) al collegamento 9: funzionamento continuo a riscaldamento immediato senza positivo al collegamento 9: ciclo di riscaldamento per 1 ora

9 Wiring diagrams • Plans de connexions • Schemi collegamenti elettrici

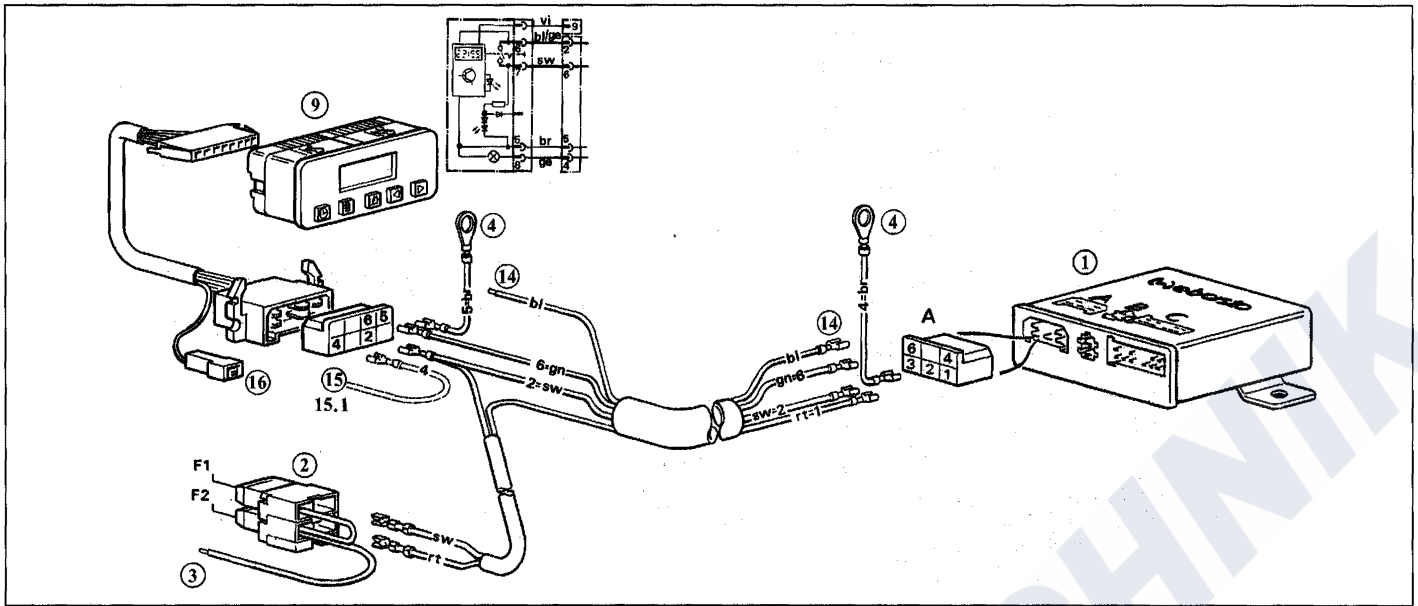

Fig. 26: Example for application in connection with automatic control wiring diagram Fig. 15 for Air Top 18

Fig. 26: exemple d'utilisation en rapport avec le schéma de connexion automatique, fig. 15 pour Air Top 18

Fig. 26: esempio di applicazione in collegamento con schema automatismi fig. 15 per Air Top 18

Connection control unit / fuse holder / Timer (7 days)

connexion organe de commande/porte-fusibles/minuterie de présélection (7 jours)

Collegamento centralina/portafusibili/timer digitale 1522 (7 giorni)

- 1 Control unit
- 2 Fuse holder
- 3 To battery (+)
- 4 Ground (-)
- 9 Timer (7 days)
- 14 Not used
- 15 Lighting (terminal 58)
- 15.1 If battery switch is connected to the negative (-) side, see example for application on page 63
- 16 If positive pole of terminal (75/15) is connected to terminal 9: continuous operation in "instant heat" mode as long as ignition is on. If positive pole of terminal (30) is connected to terminal 9: continuous operation in the "instant heat" mode. If positive pole is not connected to terminal 9, heating duration 1 hour.

- 1 organe de commande
- 2 porte-fusibles
- 3 vers la batterie (+)
- 4 la masse (-)
- 9 minuterie de présélection (7 jours)
- 14 vierge
- 15 éclairage (borne 58)
- 15.1 disjoncteur de batterie sur pôle négatif: se référer à exemple d'utilisation page 63
- 16 côté positif de la borne (75/15) sur raccord 9: service continu lors du chauffage immédiat tant que l'allumage est amorcé côté positif de la borne (30) sur raccord 9: service continu lors du chauffage immédiat sans pôle positif sur raccord 9: durée de chauffage: 1 heure

- 1 Centralina
- 2 Portafusibili
- 3 alla batteria (+)
- 4 Massa (-)
- 9 Timer digitale (7 giorni)
- 14 non occupato
- 15 Illuminazione (morsetto 58)
- 15.1 con interruttore d. batteria su negativo vedi esempio di applicazione pag. 63
- 16 con positivo d. morsetto (75/15) al collegamento 9: ciclo continuo a riscaldamento immediato finchè accensione accesa con positivo d. morsetto (30) al collegamento 9: funzionamento continuo a riscaldamento immediato senza positivo al collegamento: ciclo di riscaldamento per 1 ora

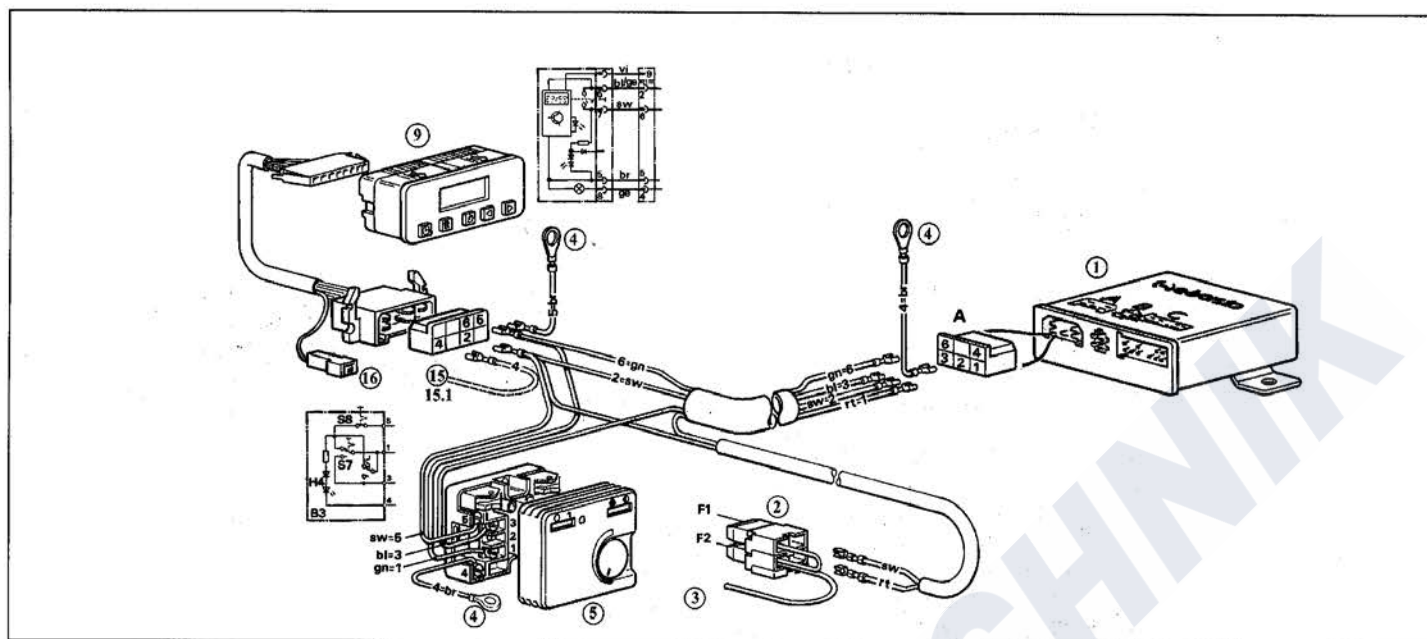

Fig. 27: Example for application in connection with automatic control wiring diagram Fig. 15 for Air Top 18

Fig. 27: exemple d'utilisation en rapport avec le schéma de connexion automatique, fig. 15 pour Air Top 18

Fig. 27: esempio di applicazione in collegamento con schema automatismi fig. 15 per Air Top 18

Connection control unit / fuse holder / room thermostat (mechanical) / timer (7 days)

connexion organe de commande/porte-fusibles/thermostat ambiant (mécanique)/minuterie de présélection (7 jours)

Collegamento centralina/portafusibili/termostato ambiente (meccanico)/timer digitale (7 giorni)

- 1 Control unit
- 2 Fuse holder
- 3 To battery (+)
- 4 Ground (-)
- 5 Interior-temperature thermostat (mechanical)
- 9 Timer (7 days)
- 14 Not used
- 15 Lighting (terminal 58)
- 15.1 If battery switch is connected to the negative (-) side, see example for application on page 63
- 16 If positive pole of terminal (75/15) is connected to terminal 9: continuous operation in "instant heat" mode as long as ignition is on. If positive pole of terminal (30) is connected to terminal 9: continuous operation in the "instant heat" mode.
If positive pole is not connected to terminal 9. heating duration 1 hour.

- 1 organe de commande
- 2 porte-fusibles
- 3 vers la batterie (+)
- 4 la masse (-)
- 5 thermostat ambiant (mécanique)
- 9 minuterie de présélection (7 jours)
- 14 vierge
- 15 éclairage (borne 58)
- 15.1 disjoncteur de batterie sur pôle négatif: se référer à exemple d'utilisation page 63
- 16 côté positif de la borne (75/15) sur raccord 9: service continu lors du chauffage immédiat tant que l'allumage est amorcé côté positif de la borne (30) sur raccord 9: service continu lors du chauffage immédiat
sans pôle positif sur raccord 9: durée de chauffage: 1 heure

- 1 Centralina
- 2 Portafusibili
- 3 alla batteria (+)
- 4 Massa (-)
- 5 Termostato ambiente (meccanico)
- 9 Timer digitale (7 giorni)
- 14 non occupato
- 15 Illuminazione (morsetto 58)
- 15.1 con interruttore d. batteria su negativo vedi esempio di applicazione pag. 63 con positivo d. morsetto (75/15) al collegamento 9: ciclo continuo a riscaldamento immediato finchè accensione accesa con positivo d. morsetto (30) al collegamento 9: funzionamento continuo a riscaldamento immediato senza positivo al collegamento 9: ciclo di riscaldamento per 1 ora

9 Wiring diagrams • Plans de connexions • Schemi collegamenti elettrici

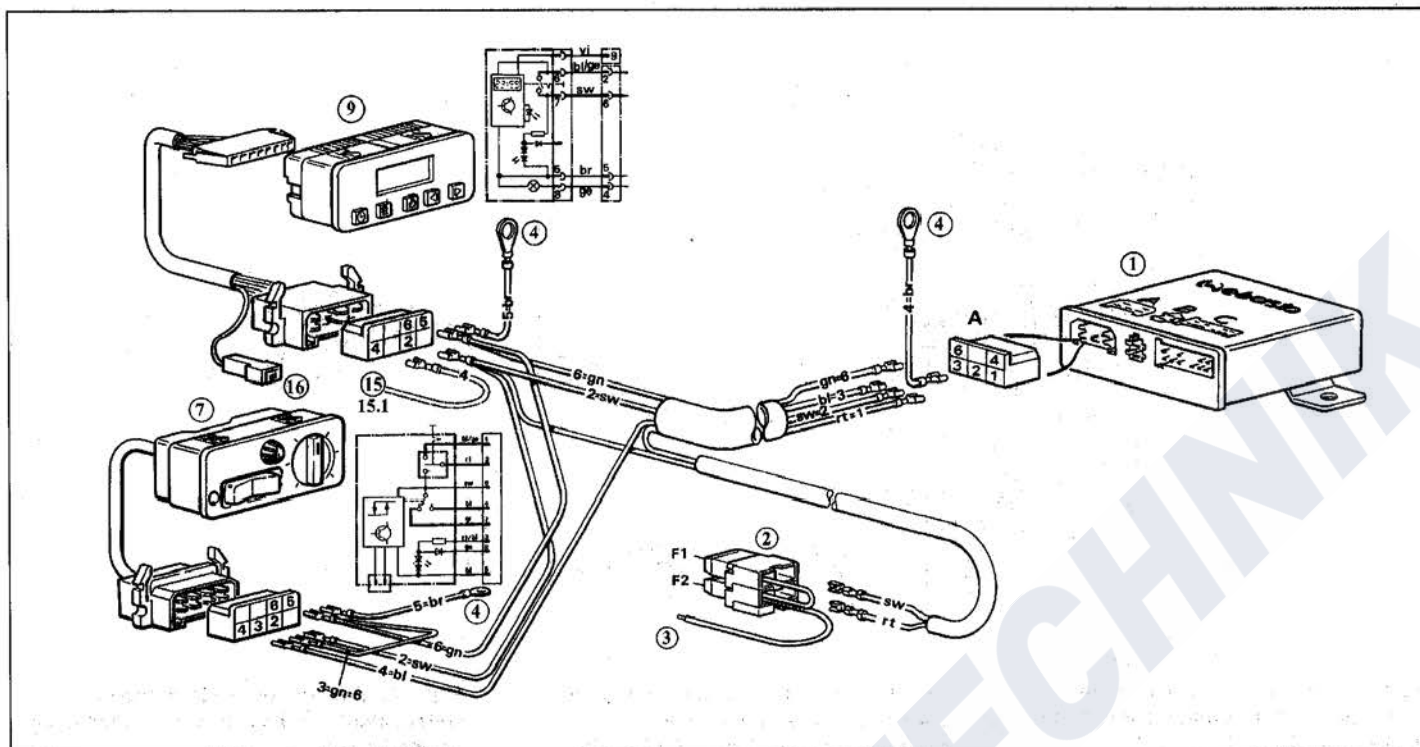

Fig. 28: Example for application in connection with automatic control wiring diagram Fig. 15 for Air Top 18

Fig. 28: exemple d'utilisation en rapport avec le schéma de connexion automatique, fig. 15 pour Air Top 18

Fig. 28: esempio di applicazione in collegamento con schema automatismi fig. 15 per Air Top 18

Connection control unit / fuse holder / room thermostat (electronic) / timer (7 days)

connexion organe de commande/porte-fusibles/thermostat ambiant (électronique)/minuterie de présélection (7 jours)

Collegamento centralina/portafusibili/termostato ambiente (elettronico)/timer digitale (7 giorni)

- 1 Control unit
- 2 Fuse holder
- 3 To battery (+)
- 4 Ground (-)
- 7 Interior-temperature thermostat (electronic)
- 9 Timer (7 days)
- 14 Not used
- 15 Lighting (terminal 58)
- 15.1 If battery switch is connected to the negative (-) side, see example for application on page 63
- 16 If positive pole of terminal (75/15) is connected to terminal 9: continuous operation in "instant heat" mode as long as ignition is on. If positive pole of terminal (30) is connected to terminal 9: continuous operation in the "instant heat" mode. If positive pole is not connected to terminal 9: heating duration 1 hour.

- 1 organe de commande
- 2 porte-fusibles
- 3 vers la batterie (+)
- 4 la masse (-)
- 7 thermostat ambiant (électronique)
- 9 minuterie de présélection (7 jours)
- 14 vierge
- 15 éclairage (borne 58)
- 15.1 disjoncteur de batterie sur pôle négatif: se référer à exemple d'utilisation page 63
- 16 côté positif de la borne (75/15) sur raccord 9: service continu lors du chauffage immédiat tant que l'allumage est amorcé côté positif de la borne (30) sur raccord 9: service continu lors du chauffage immédiat sans pôle positif sur raccord 9: durée de chauffage: 1 heure

- 1 Centralina
- 2 Portafusibili
- 3 alla batteria (+)
- 4 Massa (-)
- 7 Termostato ambiente (elettronico)
- 9 Timer digitale (7 giorni)
- 14 non occupato
- 15 Illuminazione (morsetto 58)
- 15.1 con interruttore d. batteria su negativo vedi esempio di applicazione pag. 63 con positivo d. morsetto (75/15) al collegamento 9: ciclo continuo a riscaldamento immediato finché accensione accesa con positivo d. morsetto (30) al collegamento 9: funzionamento continuo a riscaldamento immediato senza positivo al collegamento 9: ciclo di riscaldamento per 1 ora