

Wasserheizgerät
Water heater
水暖型加热器

Einbauanweisung
Installation Instructions
安装指导

Thermo Top C

Thermo Top Z - D (Diesel) (diesel) (柴油)

Thermo Top Z/C - D (Diesel) (diesel) (柴油)

(zur Standheizung aufgerüstete Thermo Top Z)

(upgraded parking heater Thermo Top Z)

(为驻车加热配备的 Thermo Top Z)

Thermo Top E - B (Benzin) (petrol) (汽油)

Thermo Top E - D (Diesel) (diesel) (柴油)

Thermo Top C - B (Benzin) (petrol) (汽油)

Thermo Top C - D (Diesel) (diesel) (柴油)

Thermo Top C - PME (Biodiesel) (biodegradable diesel) (生物柴油)

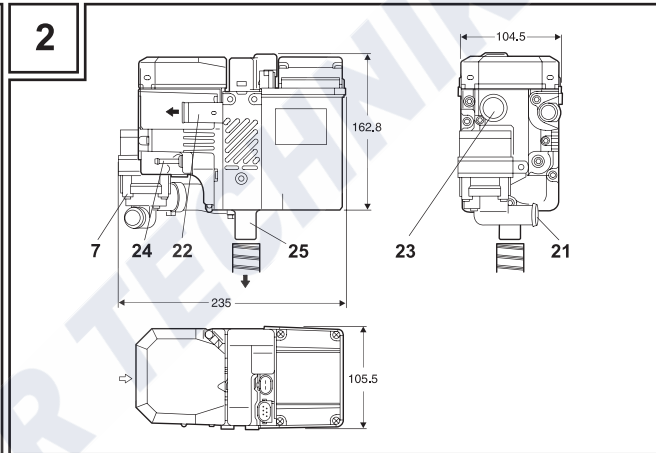
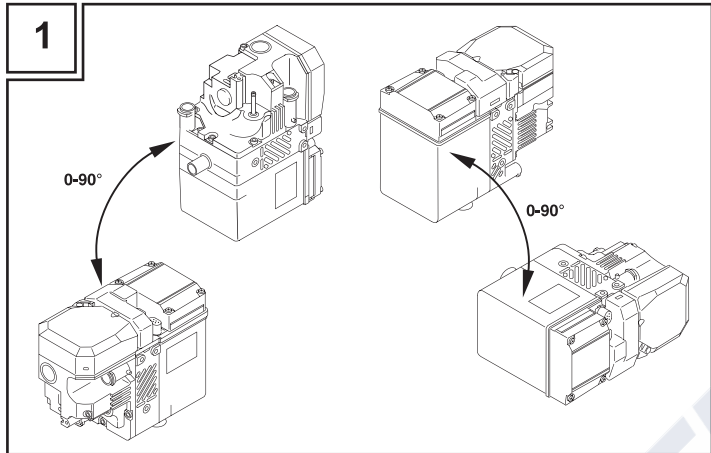

3

Webasto Thermo & Comfort SE		E1	122R - 00 0002
Made in Germany	CE		10 R - 03 1232
Model Type	Thermo Top C		
Operating Voltage	12 V		
Rated Output	5,0 kW		
Fuel Type	xxxxxx		
Working Pressure	max. 2,5 bar		
Part No. %%%-%	Serial No. XAJJXXXXXXX		
Year of Manufacture	YY	YY	YY

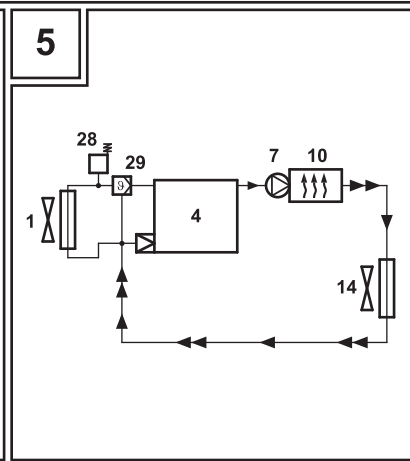
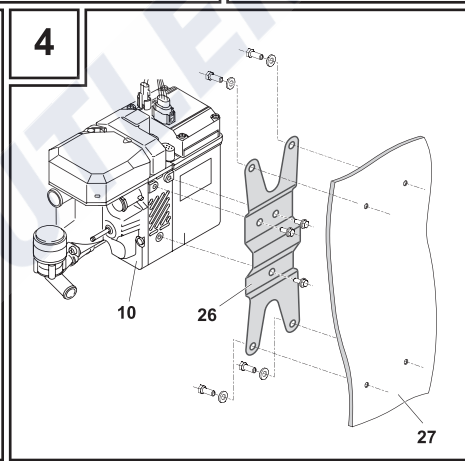

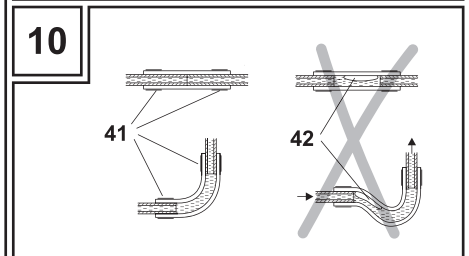
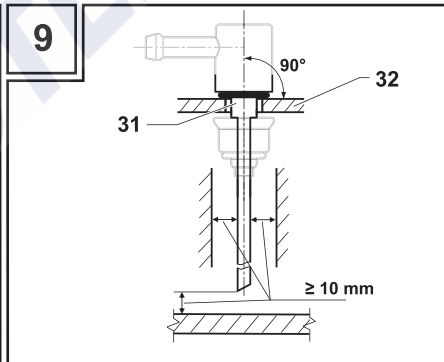
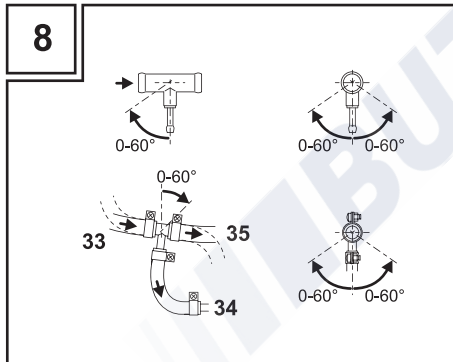
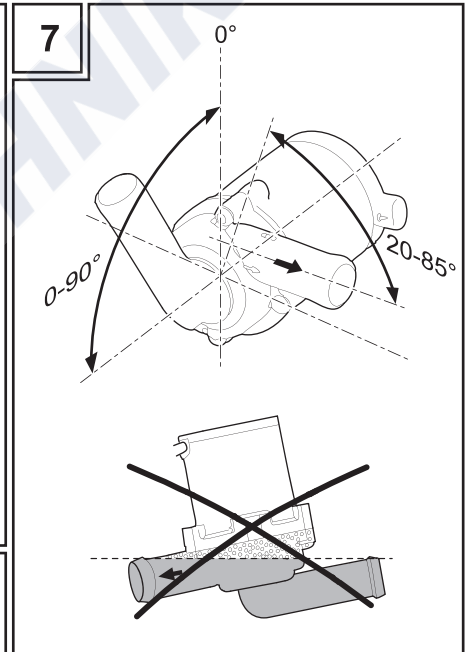
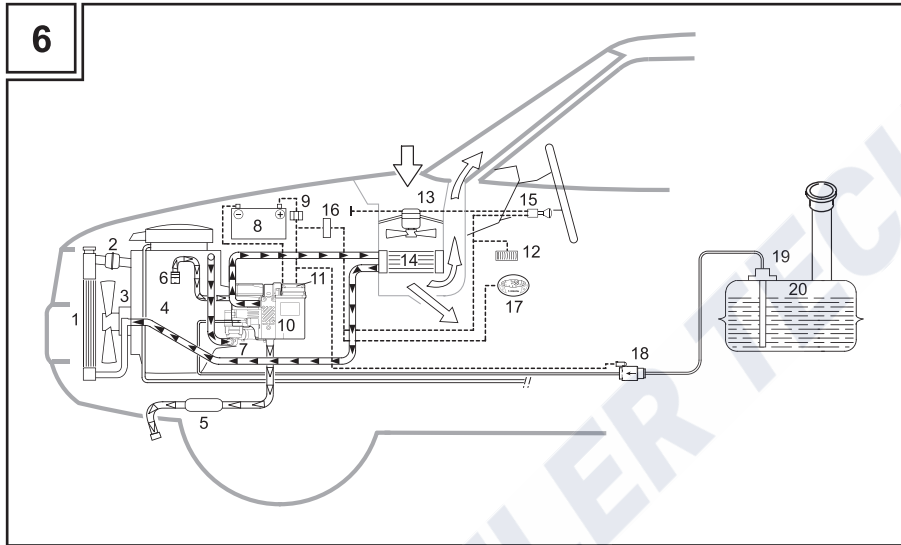

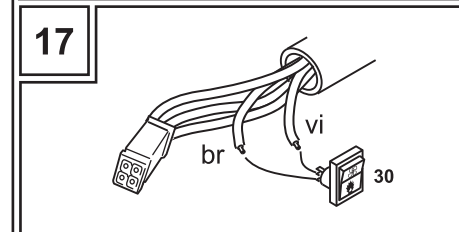
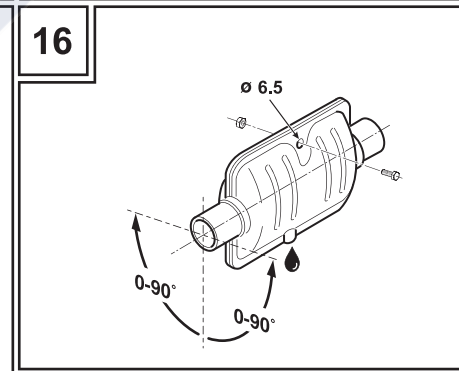
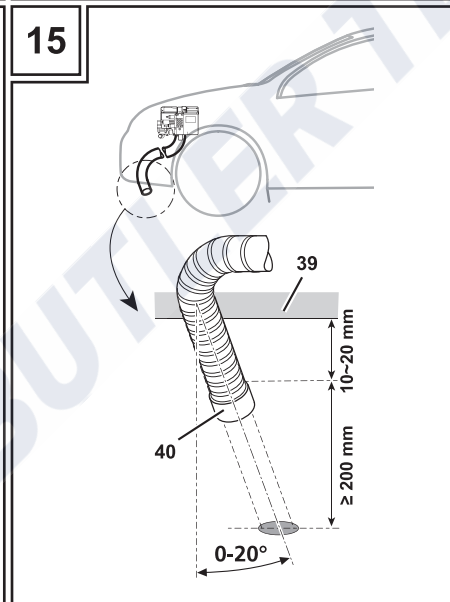
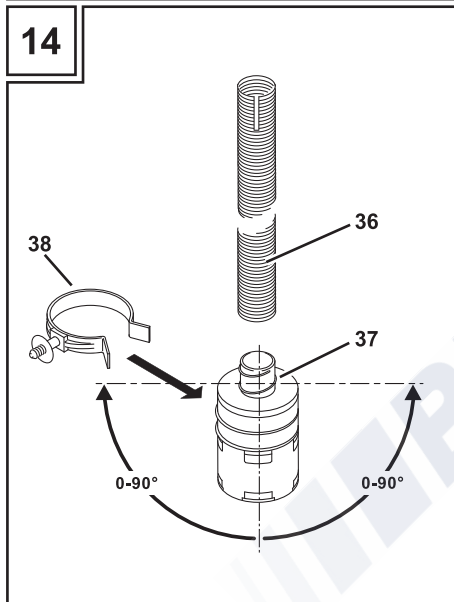
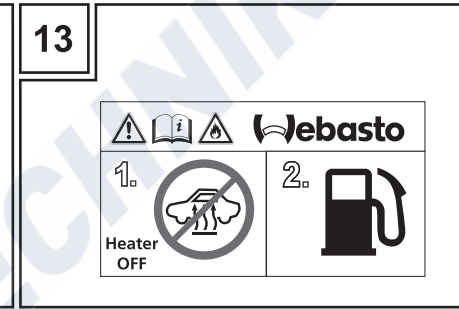
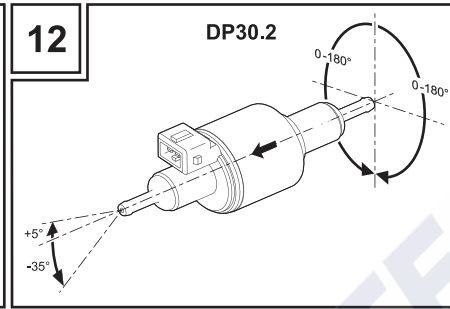
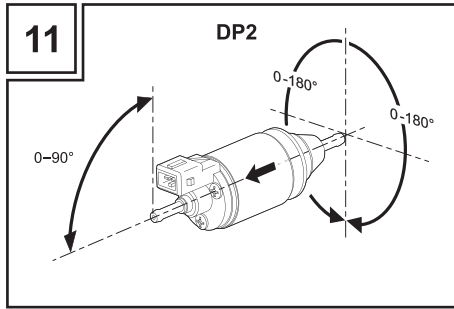
18

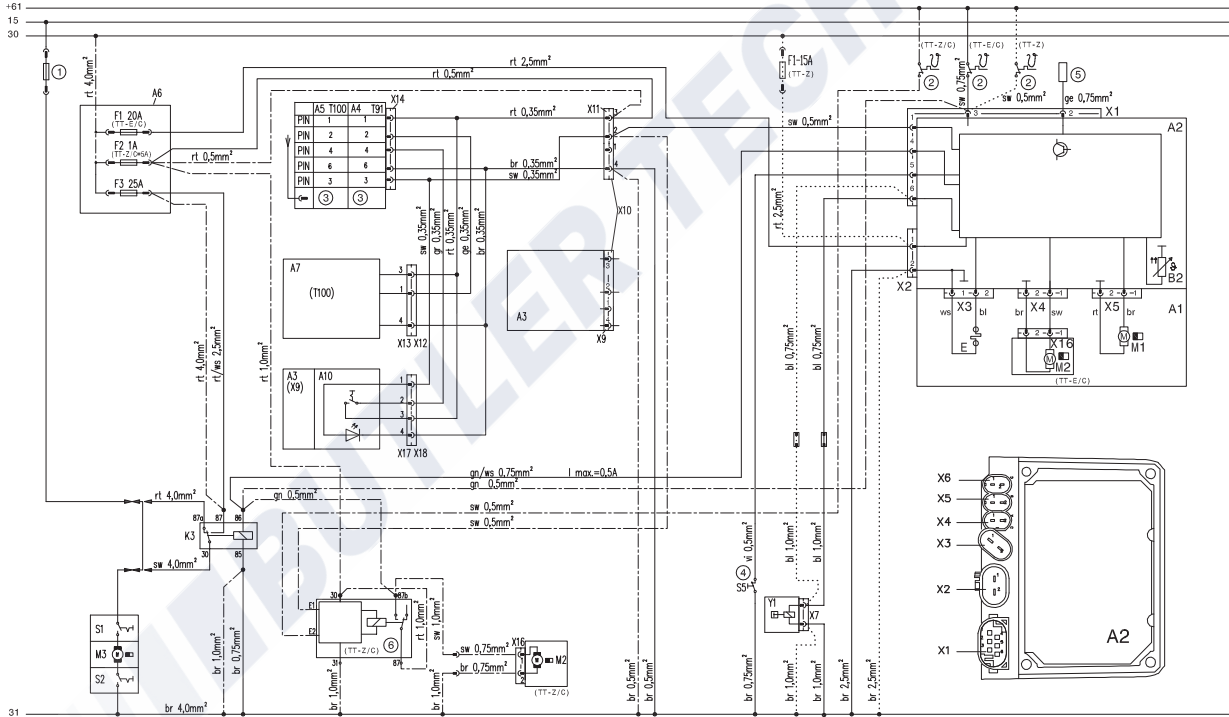
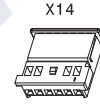
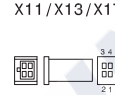
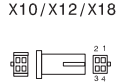
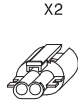
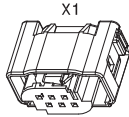

/// BUTLER TECHNIK

/// BUTLER TECHNIK



Improper installation or repair of Webasto heating and cooling systems can cause fire or the leakage of deadly carbon monoxide leading to serious injury or death.

To install and repair Webasto heating and cooling systems you need to have completed a Webasto training course and have the appropriate technical documentation, special tools and special equipment.

Only genuine Webasto parts may be used. See also Webasto air and water heaters accessories catalogue.



NEVER try to install or repair Webasto heating or cooling systems if you have not completed a Webasto training course, you do not have the necessary technical skills and you do not have the technical documentation, tools and equipment available to ensure that you can complete the installation and repair work properly.

ALWAYS carefully follow Webasto installation and repair instructions and heed all WARNINGS.

Webasto rejects any liability for problems and damage caused by the system being installed by untrained personnel.

GB Table of Contents

1	Regulations Governing Installation	20	10	Exhaust System	30
	1.1. Statutory regulations governing installation.....	20		10.1. Exhaust pipe	30
	1.2. Additional documentation to be used	20		10.2. Exhaust silencer.....	30
2	Use / Version	21		10.3. Recommendations for installation	30
	2.1. Use of the water heaters	21	11	Electrical Connections	31
	2.1.1. Parking heater	21		11.1. Connection of control unit / heater	31
	2.1.2. Auxiliary heater	21		11.2. Installation and connection of the timer	31
	2.2. Version	21		11.3. Installation of other heater controls.....	31
3	Installation Location and Installation Position	22		11.4. Vehicle fan (not with Thermo Top Z)	31
4	Type Label	23		11.5. Connection of summer/winter switch (option only with Thermo Top E or C).....	31
5	Standard Bracket	23	12	Circuit Diagrams	32
6	Example of Installation in a Passenger Car	23	13	Initial Start-Up	34
7	Integration in Coolant System.....	24	14	Faults	34
	7.1. Connection.....	24	15	Technical Data	35
	7.2. Installing coolant hoses	24		15.1. Technical data of circulation pump.....	35
	7.3. Retrofitting or detaching circulation pump	24		15.2. Technical data of metering pump.....	35
	7.4. Checking	25		15.3. Technical Data for Thermo Top Z/E/C	36
8	Fuel Integration	26			
	8.1. Integration in engine supply or return line.....	26			
	8.2. Integration via fuel removal unit.....	26			
	8.3. Fuel line	27			
	8.3.1. Line installation	27			
	8.3.2. Line design	27			
	8.3.3. Connecting two lines with a hose.....	27			
	8.3.4. Metering pump	27			
	8.3.5. Installation location	28			
	8.3.6. Installation and attachment	28			
	8.4. Label.....	28			
	8.5. Cold-resistant fuels	28			
9	Combustion Air Supply.....	29			
	9.1. Combustion air pipe	29			
	9.2. Intake silencer.....	29			
	9.3. Recommendations for installation	29			

//// BUTLER TECHNIK

Explanatory Notes on Document

To provide you with a quick overview of the individual working steps, you will find an identification mark on the outside top right corner of the page in question.

Sections in *italics* contain an excerpt from the Directive ECE R122.

Mechanical system

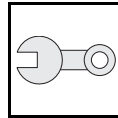

Electrical system



Coolant circuit

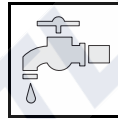

Fuel

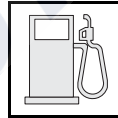

Exhaust gas

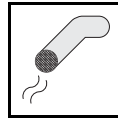

Combustion air

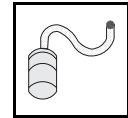

Technical information



Caution



Note

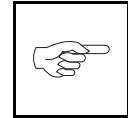



1 Regulations Governing Installation

1.1. Statutory regulations governing installation

Type approvals according to ECE-R 10 (EMC) and ECE R-122 (Heater) exist for the Thermo Top Z/E/C heaters.

See chapter 15, "Technical Data" for the approval number.



The provisions of these Directives are binding within the territory governed by EU Directive 70/156/EEC and/or EC/2007/46 (binding for new vehicle types as of 29/04/2009) and should also be observed in countries in which there are no special regulations!



Failure to follow the installation instructions and the notes contained therein will lead to all liability being refused by Webasto. The same applies if repairs are carried out incorrectly or with the use of parts other than genuine spare parts. This will result in the invalidation of the type approval for the heater and therefore of its homologation/ECE type approval.

1.2. Additional documentation to be used

These installation instructions do not contain all necessary information and instructions with regard to the installation of Thermo Top Z/E/C heaters.

In addition, the operating instructions and the vehicle-specific installation instructions must also be used.



2 Use / Version

2.1. Use of the water heaters

2.1.1. Parking heater

The Thermo Top Z/E/C water heaters were designed for installation in Class M1 motor vehicles. Installation in Class O, N2 and N3 motor vehicles and vehicles for transporting hazardous substances is not permissible. When installing in special vehicles, the applicable regulations must be taken into account. Other uses are possible in consultation with Webasto.

The Webasto Thermo Top E, C and Z/C water heaters is used in conjunction with the original vehicle heating system

- to heat the passenger compartment,
- to defrost the vehicle windows,
- to preheat water-cooled engines (if technically possible).

The water heaters operate independently of the vehicle engine and are integrated in the vehicle's cooling system, fuel system and electrical system

2.1.2. Auxiliary heater

The Webasto Thermo Top Z water heater operates depending on the vehicle engine and is integrated in the vehicle's cooling system, fuel system and electrical system.

When the engine is switched off, the water heater unit is automatically also switched off and the fuel supply is cut off within 5 seconds.

2.2. Version

Thermo Top E - B Parking Heater/Auxiliary Heater

Water heater for "petrol" fuel

Thermo Top E - D Parking Heater/Auxiliary Heater

Water heater for "diesel" fuel

Thermo Top C - B Parking Heater/Auxiliary Heater

Water heater for "petrol" fuel

Thermo Top C - D Parking Heater/Auxiliary Heater

Water heater for "diesel" fuel

Thermo Top C - PME Parking Heater/Auxiliary Heater

Water heater for "biodiesel" fuel

Thermo Top Z - D Auxiliary Heater

Water heater for "diesel" fuel

Thermo Top Z - PME Auxiliary Heater

Water heater for "biodiesel" fuel

Thermo Top Z/C - D Parking Heater/Auxiliary Heater

Thermo Top Z upgraded to parking heater for "diesel" fuel

The Thermo Top Z/E/C water heaters are designed for 12 V.

See chapter 15, "Technical Data" for the technical design.

3 Installation Location and Installation Position

Body sections and any other components in the vicinity of the heater must be protected from excessive heat and the possibility of fuel or oil contamination. (Requirement from ECE R122, Point 5.3.2.1.).

The combustion heater shall not constitute a risk of fire, even in the case of overheating. This requirement shall be deemed to be met if the installation ensures an adequate distance to all parts and suitable ventilation, by the use of fire resistant materials or by the use of heat shields. (Requirement from ECE R122, Point 5.3.2.2.).

The heater is preferably installed in the engine compartment, in the area between the wheel arch and the front bumper.

Installation should be carried out as low as possible to ensure automatic bleeding of the heater and circulation pump.



The openings of the coolant connection may not face downward in any installation position.

Fig. 1 shows the permissible installation position of the heater.

For position of coolant fitting on heater, see fig. 2.

For dimensions of heater, see chapter 15, "Technical Data".

Legend fig. 2:

- 7) Circulation pump (optional with Thermo Top Z)
- 21) Coolant inlet connection
- 22) Coolant outlet connection
- 23) Combustion air inlet
- 24) Fuel inlet connection
- 25) Exhaust outlet connection



The heater may not be installed:

- in the direct area of radiation of exhaust systems
- below the wading line of the vehicle.
- above the coolant expansion tank.



4 Type Label

The label referred to in Annex 7, paragraph 4, or a duplicate, must be positioned so that it can be easily read when the heater is installed in the vehicle. (Requirement from ECE R122, Point 5.3.2.4.).

Inapplicable years must be erased from the model plate and the current year must be retained.

Example see also fig. 3.

5 Standard Bracket

The heater must be fastened on the bracket with at least 3x M6 bolts with 10.0 ± 1.0 Nm.

The standard bracket must be secured to the car body or an intermediate bracket with at least four M6 screws.

The bracket must not be secured to the car body with self-tapping screws. If necessary, the bracket must be properly machined in accordance with the rules of technology.

See also fig. 4: Example of a Thermo Top C bracket.

Legend:

- 10) Water heater
- 26) Bracket for heater
- 27) Body

6 Example of Installation in a Passenger Car

Fig. 6 shows an installation example of the heater in the vehicle.

Legend:

- 1) Radiator
- 2) Coolant thermostat
- 3) Coolant pump (of vehicle engine)
- 4) Internal combustion engine
- 5) Exhaust silencer
- 6) Intake silencer, combustion-air intake pipe
- 7) Circulation pump
- 8) Battery
- 9) Fuse holder
- 10) Water heater
- 11) Control unit (in heater)
- 12) Fuse block for fan of vehicle heater
- 13) Fan of vehicle heater
- 14) Heat exchanger for vehicle heater
- 15) Switch for fan of vehicle heater
- 16) Relay (for vehicle fan)
- 17) Digital timer
- 18) Fuel metering pump
- 19) Fuel removal
- 20) Fuel tank



7 Integration in Coolant System

7.1. Connection

The heater is connected to the vehicle cooling system as shown in fig. 5, 6 and 7. The coolant quantity present must at least be equivalent to the volume specified in chapter 15, "Technical Data".

It is preferable to integrate the heater in the coolant system at the heat exchanger inlet.

Legend fig. 5:

- 1) Radiator
- 4) Internal combustion engine
- 7) Circulation pump
- 10) Water heater
- 14) Heat exchanger for vehicle heater
- 28) Expansion tank
- 29) Thermostat



Any coolant running off should be collected using an appropriate container.

The coolant hoses supplied by Webasto must always be used. If other hoses are used, they must at least comply with the standard DIN 73411, material class B. The hoses must be routed without kinking and preferably uphill from the heater to ensure perfect bleeding.

Hoses with an internal diameter of 20 mm must be used.

Hose connections must be secured against slipping off with clips.

7.2. Installing coolant hoses

The clamps on the coolant fittings must be mounted between the bead and the hose shoulder.

Care must be taken to bleed the cooling system before the heater is taken into service for the first time or after refilling with fresh coolant. Heater and lines should be installed in such a way as to ensure static bleeding.

Malfunctions due to overheating may occur during operation if the heater and lines have not been bled correctly.



Only the clamps approved by Webasto may be used to secure the coolant hoses.

The hose clamps must be tightened with a tightening torque of $2.0 \pm 0.5 \text{ Nm}$.

7.3. Retrofitting or detaching circulation pump

The circulation pump can be integrated in the coolant circuit both at the location provided on the heater or detached from the heater.

The circulation pump must be installed in the coolant circuit on the pressure side on the heater heat-exchanger inlet (see fig.5).



Ensure the correct direction of flow of the circulation pump to the vehicle coolant circuit. The installation position of the circulation pump must be chosen so that the circulation pump is self-bleeding. It must be possible for the air volume trapped in the circulation pump to automatically escape upward via the connection piece. Incorrect installation can result in malfunctions of the circulation pump.

See fig. 7: Installation positions of U4847 Econ circulation pump.

7.4. Checking

After the heater and all coolant-carrying components have been installed, the entire coolant system must be checked for leaks with the system pressure specified by the vehicle manufacturer.



8 Fuel Integration

The fuel filler must not be situated in the passenger compartment and must be provided with an effective cap to prevent fuel spillage. (Requirement from ECE R122, Point 5.3.3.1.).

In the case of liquid fuel heaters, where a supply separate from that of the vehicle is provided, the type of fuel and its filler point must be clearly labelled. (Requirement from ECE R122, Point 5.3.3.2.).

8.1. Integration in engine supply or return line

The fuel integration is carried out either in the supply or return line, or with a special fuel standpipe. On vehicles with a fuel pump, the fuel may not be removed from the fuel supply line!

- If the vehicle has a check valve to the fuel tank, fuel may not be removed from the return line.
- It must be ensured that no zero balance results in the vehicle system due to the fuel removal.
- If fuel is removed from the swirl pot, it must be ensured that this pot is not completely drained.

Proper installation is carried out as shown in fig. 8: Example of a fuel standpipe.

Legend:

- 33) from tank
- 34) to metering pump
- 35) to engine

8.2. Integration via fuel removal unit

Also see chapter 6, "Example of Installation in a Passenger Car"

The fuel standpipe is installed in the fuel removal unit of the fuel tank. See fig. 9.

Legend for fig. 9:

- 31) Fuel standpipe
- 32) Fuel removal unit with hole

The installation surface of the fuel standpipe must be clean, flat and burr-free. When mounting the fuel standpipe in the fuel removal unit, ensure careful routing of the standpipe. This may not impair the operation of the parts of the fuel removal unit including the fuel gauge in any operating mode. The length of the standpipe must be chosen so that a minimum distance of 10 mm over the fuel tank bottom or 20 mm over the bottom of the fuel removal unit is ensured.

The specified securing measures of the vehicle manufacturer and the corresponding torques must be complied with.



The fuel standpipe must always be installed in the fuel tank closure plate and never directly into the body of the fuel tank.



8.3. Fuel line

The fuel line is divided into the intake and the delivery line. As a result, the intake line is a connection between the fuel tank and the metering pump, while the delivery line produces the connection between the metering pump and the heater.

8.3.1. Line installation

When installing the fuel line, it must be kept as short as possible.

Intake line length [m]	max. 1.2 m
Delivery line length [m]	max. 5.8 m

The line must be installed protected against damage (e.g. stone impact) in all areas.

The fuel line must always be routed in cool areas to prevent the formation of bubbles due to warming.

High fuel temperatures can cause heater malfunctions. As a result, the line may not be routed either past strong heat sources (e.g. exhaust gas) or near stored heat zones.

In addition, the steepest possible routing of the fuel line must be ensured from the fuel tank to the heater.

Fuel lines must be fastened in accordance with the latest technology so that, for example, line sag is avoided.

Rub protection must be installed at sharp-edged transitions.



Do not route fuel lines through the vehicle interior.

8.3.2. Line design

Only lines approved by Webasto may be used as fuel lines.

8.3.3. Connecting two lines with a hose

The correct connection of fuel lines with a hose is shown in fig. 10.

Legend for fig. 10:

41) Hose clamp

42) Air bubble

The hose clamps must be tightened with a tightening torque of $1 + 0.4 \text{ Nm}$.

Ensure that there are no leaks!

8.3.4. Metering pump

The metering pump is a combined delivery, metering and shut-off system and is subject to specific installation criteria. See fig. 11 (petrol) and 12 (diesel).

The assignment to the fuel and the permissible installation conditions are contained in chapter 15, "Technical Data".



8.3.5. Installation location

The metering pump may not be installed in the radiation area of hot vehicle parts. A heat shield must be used if necessary. The pump should preferably be installed near the tank.

The permissible ambient temperature is dependent on the fuel used, see chapter 15, "Technical Data".

8.3.6. Installation and attachment

The metering pump must be secured with a vibration-damping mounting. The installation position is restricted as shown in fig. 11 (petrol) and 12 (diesel) (maximum angle of inclination of the metering pump, axial installation position of the metering pump) to ensure good self-ventilation. The arrow indicates the direction of flow of the fuel.

8.4. Label

A notice, indicating that the heater must be shut down before refuelling, must be affixed to the fuelling point. (Requirement from ECE R122, Point 5.3.3.3.).

Use the stickers provided (see fig. 13 for an example).

The sticker "Switch off heater when refuelling" must be applied near the filler neck.

8.5. Cold-resistant fuels

If you change to low-temperature fuel, the heater must be operated for approx. 15 minutes so that fuel line and fuel pump are also filled with the new fuel.

We know of no negative influences due to additives.

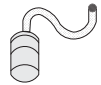

9 Combustion Air Supply

The air inlet must be so positioned or guarded that blocking by rubbish or luggage is unlikely. (Requirement from ECE R122, Point 5.3.5.2.).

9.1. Combustion air pipe

The intake opening for combustion air must be located so that it cannot become clogged with dirt. It must not point in the direction of travel.

An intake line is required for combustion air.

The withdrawal point for the combustion air must be located in a cool place where it is protected from splashing water and above the wading line of the vehicle.

Should the intake opening be located within a closed installation space, a ventilation opening of at least 3 cm² is required.

9.2. Intake silencer

The air intake silencer must be installed in a position between 0° and 90° pointing downwards.

See fig. 14.

Legend for fig. 14:

36) Combustion-air intake pipe

37) Combustion-air intake silencer

38) Mounting clip

9.3. Recommendations for installation

Mount a combustion-air intake pipe with a maximum length of 400 mm with the slotted side (approx. 18 mm) on the combustion-air intake connection piece of the heater and fasten it with the hose clamp provided. Here the hose clamp must be fastened with a tightening torque of 2.0 + 0.5 Nm.



Leaks can result in a higher noise level. Ensure an adequate distance from the exhaust system to prevent the intake of exhaust gas!

Depending on the installation, the combustion air intake silencer can be located in a suitable location and secured with the included mounting clip or other installation materials which utilise the latest technology.



10 Exhaust System

10.1. Exhaust pipe

The exhaust pipe (inside diameter 22 mm) can be routed with several bends (270° altogether, minimum bending radius 50 mm).

The total line length must be between 500 and 1000 mm.

10.2. Exhaust silencer

It is not permissible to operate the Thermo Top Z/E/C heater without an exhaust silencer.

The exhaust silencer must not be installed near the intake opening for the combustion air.

The exhaust silencer must be installed at least 200 mm from the heater.

Fig. 16 shows the exhaust silencer.

10.3. Recommendations for installation

The exhaust silencer and the exhaust pipe may not be fastened to temperature-sensitive vehicle parts (e.g. brake line, electr. lines, vehicle control units, headlights, underbody protection, plastic parts, etc.) and there must be a sufficient distance of at least 20 mm from them.

Only approved Webasto spacer brackets may be used with this application.

The exhaust pipes are sufficiently fixed in place to ensure the minimum distances even during driving. Lines approved by Webasto must be used as exhaust pipes. It is recommended that the exhaust application be installed splash-water protected.



Collections of condensed water in the exhaust pipe must be drained off directly. If necessary, a condensed-water drain hole may be drilled at the lowest point.

Condensed-water drain holes may not blow onto temperature-sensitive vehicle parts.

The exhaust outlet must be located so as to prevent emissions from entering the vehicle through ventilators, heated air inlets or opening windows. (Requirement from ECE R122, Point 5.3.4.1.).

The exhaust outlet must be unobstructed. It must not be directed at vehicle parts. The exhaust outlet may not be located within the range of throw of the wheels.

Watch the maximum steering angle of the front wheels. It must be ensured that the exhaust outlet is not clogged and cannot be damaged under any operating conditions.

The opening of the exhaust pipe must not point in the direction of travel.

Point the direction of outflow vertically downward or a maximum of 20° opposite the direction of travel.

After passing through the underbody cover, the exhaust pipe must be extended by another 10 mm.

Fig. 15: Exhaust outlet

Legend:

39) Engine under tray

40) Exhaust outlet



11 Electrical Connections

Electrical components, such as relays, fuses, switches, etc., must be installed so that they are protected from the penetration of water (splash water, high-pressure cleaners, etc.).

11.1. Connection of control unit / heater

The electrical connection of the heater is designed as shown in fig. 18.

11.2. Installation and connection of the timer

A clearly visible tell-tale in the operator's field of view shall inform when the combustion heater is switched on or off. (Requirement from ECE R122, Appendix 7, Point 7.1.).

The timer is connected as shown in the circuit diagram in fig.18.



Do not press the display of the digital timer during installation. This can result in damage to the LCD display.

11.3. Installation of other heater controls

The installation of other heater controls must be carried out in accordance with the specific installation instructions.

The Telestart is installed in accordance with its installation instructions. The Telestart transmitter is coded to the receiver as described in the Telestart operating instructions.

11.4. Vehicle fan (not with Thermo Top Z)

The vehicle fan is controlled by the fan relay, see the wiring diagram in fig. 18.



The connection in the control unit (heater) is designed for a current consumption of $I_{max} = 0.5 \text{ A}$.

11.5. Connection of summer/winter switch (option only with Thermo Top E or C)



The summer/winter switch is connected as shown in fig. 17 and the wiring diagram fig. 18.



The brown (br) and violet (vi) wires are fastened to the wiring harness with the ends insulated.

Legend for fig. 17:

- 30) Summer/winter switch
- br) Brown wire
- vi) Violet wire



12 Circuit Diagrams

Legend for wiring diagrams see fig. 18:

System wiring diagram for Thermo Top Z/E/C and Z/C, 12 V.



The line cross-sections specified in the system wiring diagram apply for line lengths < 4.5 m.

Tabelle 1: Cable colours

bl	blue
br	brown
ge	yellow
gn	green
gr	grey
or	orange
rt	red
sw	black
vi	violet
ws	white



Table 2: Legend for wiring diagrams

Item	Description	Comment
①	Vehicle fan fuse	Present in vehicle
②	External temperature sensor	Only for Thermo Top Z, Thermo Top Z/C or auxiliary heating option
③	Aerial	Only for Telearstart option
④	Ventilation option	Only Thermo Top E and Thermo Top C
⑤	Diagnosis	All heaters
⑥	Mini-relay	Only with upgrade from Thermo Top Z to Thermo Top Z/C
A1	Heater	Thermo Top Z/E/C or Z/C
A2	Control unit	All heaters
A3	Digital timer 1533	
A4	Telearstart T91	
A5	Telearstart T100 HTM	
A6	Fuse holder	Thermo Top E/C and Z/C
A7	W bus temperature sensor	Only Telearstart T100 HTM
A10	Telearstart button	
B2	Coolant temperature sensor	Integrated in control unit
E	Glow plug/flame monitor	
F1	Fuse	20 A (with Thermo Top Z: 15 A)
F2	Fuse	1 A (with Thermo Top Z/C: 5 A)
F3	Fuse	25 A
K3	Relay	Vehicle fan
M1	Motor	Combustion air fan
M2	Motor	Circulation pump
M3	Motor	Vehicle fan

Item	Description	Comment
S1	Vehicle fan switch	S1 or S2 depending on vehicle
S2	Vehicle fan switch	S1 or S2 depending on vehicle
S5	Switch	Summer/winter switch
X1	6-pin connector	Heater control unit
X2	2-pin connector	Heater power supply
X3	2-pin connector	Glow plug/flame monitor
X4	2-pin connector	Circulation pump (only with Thermo Top E/C)
X5	2-pin connector	Combustion air fan
X6	2-pin connector	not in use
X7	2-pin connector	Metering pump
X9	4-pin connector	Digital timer
X10	4-pin connector	Heater controls
X11	4-pin connector	Heater controls
X12	4-pin connector	Temperature sensor for W bus
X13	4-pin connector	Temperature sensor for W bus
X14	6-pin connector	Telearstart T91/T100 HTM
X16	2-pin connector	Circulation pump
X17	4-pin connector	Push button
X18	4-pin connector	Digital timer or push button
Y1	Metering pump	DP2 or DP30.2
-----	Connection line for Thermo Top Z only	Retail accessories for auxiliary heater
- - - - -	Connection line only for Thermo Top Z/C	Thermo Top Z upgraded to parking heater
—————	Connection line only with Thermo Top E/C	Retail accessories for parking heater

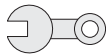

13 Initial Start-Up



The safety precautions in the operating instructions must be observed!

The operating instructions must be read through without fail before starting the heater.

After the heater has been installed, the coolant circuit and the fuel supply system must be carefully bled. Follow the instructions supplied by the vehicle manufacturer for this purpose.

It is recommended that the heater circulation pump be put into operation with the component test function of the Webasto Thermo Test PC Diagnosis to support bleeding.

Before the heater is operated for the first time, the coolant temperature should be $< 30^{\circ}\text{C}$, as the heater does not go into combustion operation at high engine temperatures.

Carry out first-time operation with the Webasto Thermo Test PC Diagnosis.

Prime the heater with fuel using the Webasto Thermo Test:

Press the "Fuel prime" button and fill the lines until fuel is present at the heater.

Example:

30 s filling time with 3,000 mm line length, metering pump frequency 5 Hz.

The CO_2 setting must be checked while operating the heater for the first time (for value range, see chapter 15, "Technical Data").

Webasto recommends a setting of 10 vol. %.

All coolant and fuel connections must be checked for leaks and secure attachment during the trial run of the heater. If the heater suffers a fault during operation, the fault must be located and remedied.

14 Faults

To remedy a fault which has resulted in a fault lock-out, proceed according to the workshop manual.



15 Technical Data

Except where limit values are specified, the technical data below refer to the usual heater tolerances of $\pm 10\%$ at an ambient temperature of $+20\text{ }^{\circ}\text{C}$ and at the rated voltage.

15.1. Technical data of circulation pump

Circulation pump	4847 Econ
Volume flow rate [l/h] toward 0.1 bar	approx. 900
Nominal voltage [V]	12
Operating voltage range [V]	9 to 16.5
Nominal power consumption [W]	14
Dimensions of circulation pump [mm]	Max. length 95 Diameter 48.5
Weight [kg]	approx. 0.3

15.2. Technical data of metering pump

Metering pump	DP2	DP30.2
Fuel	Petrol	Diesel
Nominal voltage [V]	12	12
Perm. pre-pressure on intake side [bar]	-0.1 to +1.5	-0.2 to +0.2
Pumping quantity [ml/h] at perm. operating temperature and clocking of 1 Hz	228	228
Perm. operating temperature [$^{\circ}\text{C}$]	-40 to +20	-40 to +20
Perm. ambient temperature during operation [$^{\circ}\text{C}$]	-40 to +20	-40 (-20 for PME) to +20

Heater	Operation	Thermo Top C - B	Thermo Top Z - D Thermo Top C - D	Thermo Top E - B	Thermo Top E - D
EC approval mark		E1 10R - 03 1232 E1 122R - 00 0002 E1 122R - 00 0003			
Model		Water heater with evaporator-type burner			
Fuel		Petrol EN 228 DIN 51625	Diesel/PME EN 590 DIN EN 14214	Petrol EN 228 DIN 51625	Diesel EN 590
Heat flow [kW]	Full load Part load	5.2 2.5		4.2 2.5	
Fuel consumption +/- 10% [l/h]	Full load Part load	0.70 0.34	0.61 0.30	0.56 0.34	0.49 0.30
Nominal power consumption (without circulation pump and vehicle fan) +/- 10% [W]	Full load Part load	28 18		23 18	
Nominal voltage [V]		12			
Operating voltage range [V]		10.5 to 15			
Bias current consumption [mA]		< 1.0			
Perm. ambient temperature [°C] Heater: - Operation - Storage		-40 to +60 -40 to +120			
Perm. operating pressure (heat exchanger) [bar]		0.4 to 2.5			
Capacity of the heat exchanger [l]		0.15			
Minimum quantity of coolant circuit [l]		4.0		3.0	
Minimum flow rate for heater [l/h]		250			
CO ₂ in exhaust gas (perm. function range) [vol. %]		8 to 12.0			
Dimensions of heater without attached parts Also see fig. 2. [mm] (Tolerance ± 3 mm)		Length: 214 Width: 106 Height: 168			
Weight [kg]		2.9			

/// BUTLER TECHNIK

Bei mehrsprachiger Ausführung ist Deutsch verbindlich.

Die Telefonnummer des jeweiligen Landes entnehmen Sie bitte dem Webasto Servicestellenfaltblatt oder der Webseite Ihrer jeweiligen Webasto-Landesvertretung.

In multilingual versions the German language is binding.

The telephone number of each country can be found in the Webasto service center leaflet or the website of the respective Webasto representative of your country.

对于多国语言版本，以德语版为准。

每个国家的联系电话都能够在伟博思通的服务中心或者你所在国家的伟博思通官方网站上找到。

Webasto Thermo & Comfort SE
Postfach 1410
82199 Gilching
Germany

Visitors' address:
Friedrichshafener Str. 9
82205 Gilching
Germany

Internet: www.webasto.com

Technical Extranet: <http://dealers.webasto.com>

Nur innerhalb von Deutschland
Tel.: 01805 93 22 78
(€ 0,14/Min. aus dem deutschen Festnetz)
E-mail: technikcenter@webasto.com