

**Bootluftheizgeräte  
Boat Air Heaters  
Scheepsluchtverwarmingsapparaten**

**Einbauanweisung  
Installation Instructions  
Montagehandleiding**

**Air Top 2000 STC  
Air Top Evo 40  
Air Top Evo 55**

Handelsbezeichnungen/Trade names/Handelsbenamingen:

Air Top 2000 STC D	(Diesel/PME)
Air Top Evo 40 D	(Diesel/PME)
Air Top Evo 55 D	(Diesel/PME)



Das unsachgemäße Einbauen oder Reparieren von Webasto Heiz- und Kühlsystemen kann Feuer verursachen oder zum Austritt von tödlichem Kohlenmonoxid führen. Dadurch können schwere oder tödliche Verletzungen hervorgerufen werden.

Für den Einbau und die Reparatur von Webasto Heiz- und Kühlsystemen bedarf es eines Webastotrainings, technischer Dokumentation, Spezialwerkzeuge und einer Spezialausrüstung.

Es dürfen nur Originalteile von Webasto verwendet werden. Siehe dazu auch Zubehörkatalog Luft- und Wasserheizgeräte von Webasto.



Versuchen Sie NIEMALS, Webasto Heiz- oder Kühlsysteme einzubauen oder zu reparieren, wenn Sie das Webastotraining nicht erfolgreich abgeschlossen und dabei die notwendigen technischen Fähigkeiten erworben haben und die für einen sachgerechten Einbau und Reparatur nötigen technischen Dokumentationen, Werkzeuge und Ausrüstungen nicht zur Verfügung stehen.

Befolgen Sie IMMER alle Webasto Einbau- und Reparaturanleitungen, und beachten Sie alle Warnhinweise.

Webasto übernimmt keine Haftung für Mängel und Schäden, die auf einen Einbau durch ungeschultes Personal zurückzuführen sind.



Improper installation or repair of Webasto heating and cooling systems can cause fire or the leakage of deadly carbon monoxide leading to serious injury or death.

To install and repair Webasto heating and cooling systems you need to have completed a Webasto training course and have the appropriate technical documentation, special tools and special equipment.

Only genuine Webasto parts may be used. See also Webasto air and water heaters accessories catalogue.

NEVER try to install or repair Webasto heating or cooling systems if you have not completed a Webasto training course, you do not have the necessary technical skills and you do not have the technical documentation, tools and equipment available to ensure that you can complete the installation and repair work properly.

ALWAYS carefully follow Webasto installation and repair instructions and heed all WARNINGS.

Webasto rejects any liability for problems and damage caused by the system being installed by untrained personnel.



DE

## Inhaltsverzeichnis

1	Erläuterungen zum Dokument	1
2	Bestimmungen für den Einbau	2
3	Verwendung / Ausführung	3
4	Heizgerät	4
5	Kalt- und Warmluft	12
6	Brennstoffversorgung	17
7	Brennluftversorgung	24
8	Abgasanlage	26
9	Elektrische Anschlüsse	30
10	Schaltpläne	39
11	Erstinbetriebnahme	48
12	Störungen	48
13	Technische Daten	49

EN

## Table of Contents

1	About This Document	52
2	Regulations governing installation	53
3	Use / variants	54
4	Heater	55
5	Cold and hot air	63
6	Fuel supply	68
7	Combustion air supply	75
8	Exhaust system	77
9	Electrical Connections	81
10	Wiring diagrams	89
11	Initial start-up	100
12	Malfunctions	100
13	Technical Data	101

## 1 About This Document

To enable quick reference to the individual procedures you will find a descriptive symbol on the top outer edge of each page.

**Mechanical system**

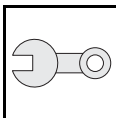

**Electrical system**



**Heated air**



**Fuel**

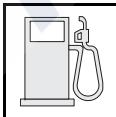

**Exhaust**

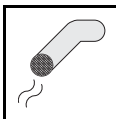

**Combustion air**

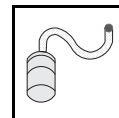

**Technical Information**



**Attention**



**Note**

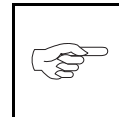

**Excerpt from directive**

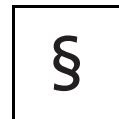



### 2 Regulations governing installation

#### 2.1. Statutory regulations governing installation

Permit numbers see Chapter 13, "Technical Data".

#### 2.2. Application of combustion heaters on boats

- Observe regional authority regulations! Establish which regulations apply in the area where the boat is to be used. Comply with the stipulated requirements!
- Obtain official approval if necessary!
- The cables must be installed and firmly secured such that the wirings are adequately protected against mechanical and thermal stress.

#### Requirements relating to the basic unit:

When switched off, it is permissible for combustion heaters to continue running for max. 40 seconds. Only combustion heaters are to be used with heat exchangers that are not damaged during their standard operating period by the reduced afterrunning time of 40 seconds.

#### 2.3. Additional documentation to be used



These installation instructions contain all the information and instructions necessary to install Air Top 2000 STC / Evo 40 / Evo 55 heaters.  
The operating instructions must also be observed.



## Marine Air Heaters

### *Air Top 2000 STC / Evo 40 / Evo 55*

---

#### 3 Use / variants

##### 3.1. Use

The Webasto Air Top 2000 STC, Air Top Evo 40 and Air Top Evo 55 air heaters are suitable for:

- Preheating and heating ship's cabins, cargo holds, passenger and crew areas
- Use on inland waterways and at sea
- Sailing and motor boats of approx. 8 to 24 m in length

Not suitable for:

- Continuous heating of living areas, houseboats, etc.!
- Heating and/or drying living creatures.

The heaters operate independently of the boat's engine. They are connected to the boat's fuel tank and electrical system.

##### 3.2. Variants

Air heater for "diesel" fuel (12 or 24 V):

- Air Top 2000 STC D (Diesel)
- Air Top Evo 40 D (Diesel)
- Air Top Evo 55 D (Diesel)



4 Heater

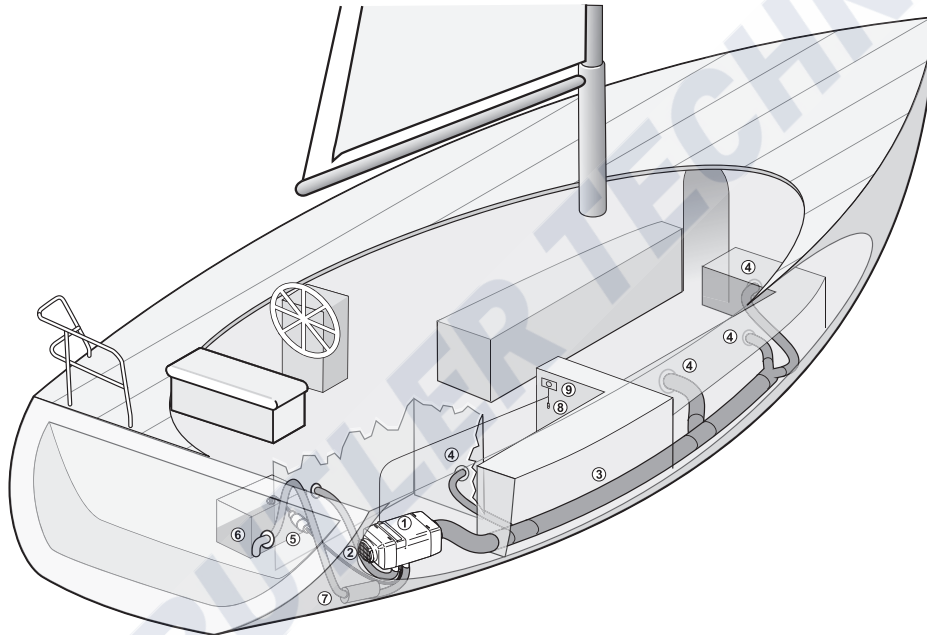

- |                     |                |                             |
|---------------------|----------------|-----------------------------|
| 1. Air heater       | 4. Air outlet; | 7. Exhaust line;            |
| 2. Cold air intake; | 5. Fuel pump;  | 8. Room temperature sensor; |
| 3. Hot air hoses;   | 6. Fuel tank;  | 9. Control element          |

Fig. 1 Installation example



## Marine Air Heaters

### Air Top 2000 STC / Evo 40 / Evo 55

#### 4.1. Choosing installation location



**ATTENTION:**

**Danger of suffocation!**

Do not install heater and exhaust system in accommodation areas.

- ▶ Install the heater in a dry location, protected from the ingress of sea water, excessive vibration, heat, engine exhaust gases and soiling by fuel or oil.
- ▶ Arrange the installation to suit the requirements and type of boat! Take the following into account: all peripheral components, such as permissible length of the exhaust system, position of the through-hull fitting, combustion air intake, routing of electrical wiring and cable lengths, distance from the fuel tank, routing of hot air hoses, fresh air intake, etc.
- ▶ Take the following into account: the maximum inclination of the boat must not result in the ingress of sea water through the exhaust gas outlet.
- ▶ The inclination must not cause the heater to come in contact with bilge water.
- ▶ No obstruction of moving parts (e.g. rudder assembly)!
- ▶ Every reasonable precaution should be taken when positioning the heater to minimise the risk of injury and damage to personal property.



**ATTENTION:**

**Danger of fire!**

- ▶ Do not install in the vicinity of flammable or temperature-sensitive objects such as sails, fenders, bulkheads, paper, gas lines, fuel containers, etc.
- ▶ When installing in locker or rudder box:
  - Only with good ventilation
  - Prevent contact with hot parts
  - Install a contact barrier around the heating system if necessary

- ▶ Recommended installation locations (see Fig. 2):

- A) In locker or rudder box if it is well ventilated.  
Install a contact barrier around the heating system so that sails, fenders, bulkheads, etc. do not come in contact with hot parts!
- B) In the engine compartment of inboard diesel engines. Condition: heating air intake from outside, combustion air intake from outside or from engine compartment if this is well ventilated to the outside!



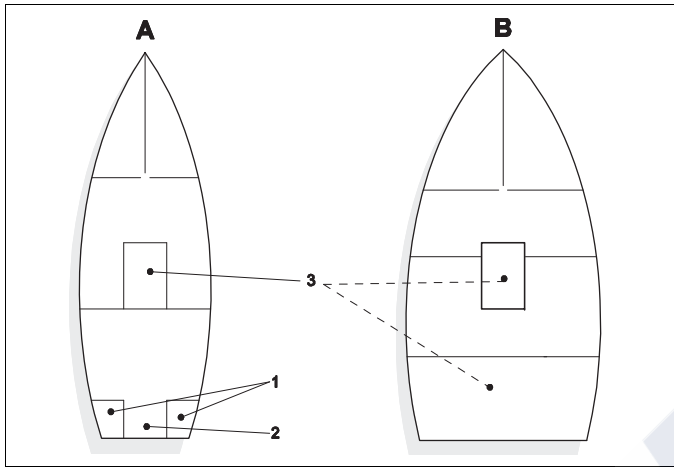
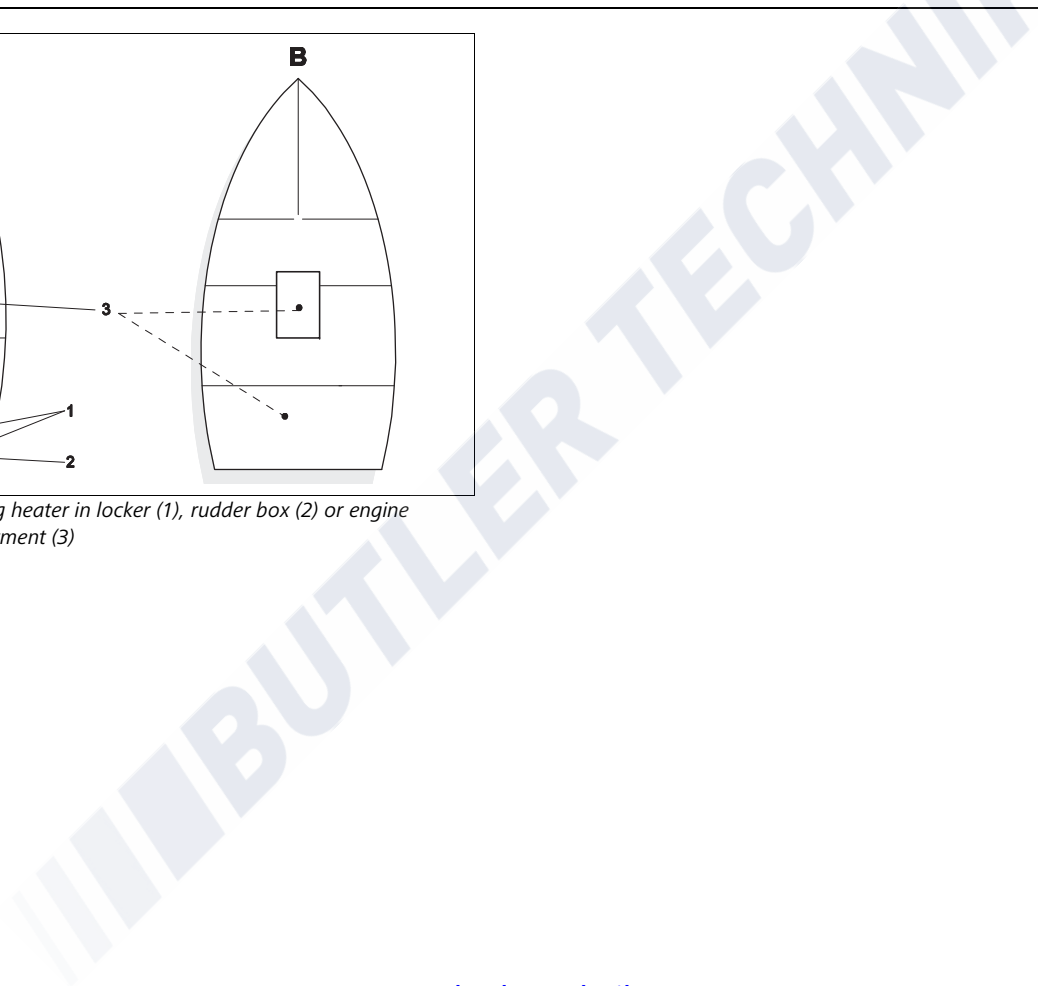

Fig. 2 Installing heater in locker (1), rudder box (2) or engine compartment (3)



# Marine Air Heaters

## Air Top 2000 STC / Evo 40 / Evo 55



### 4.2. Heater data

#### 4.2.1. Dimensions Air Top Evo 40 / Air Top Evo 55

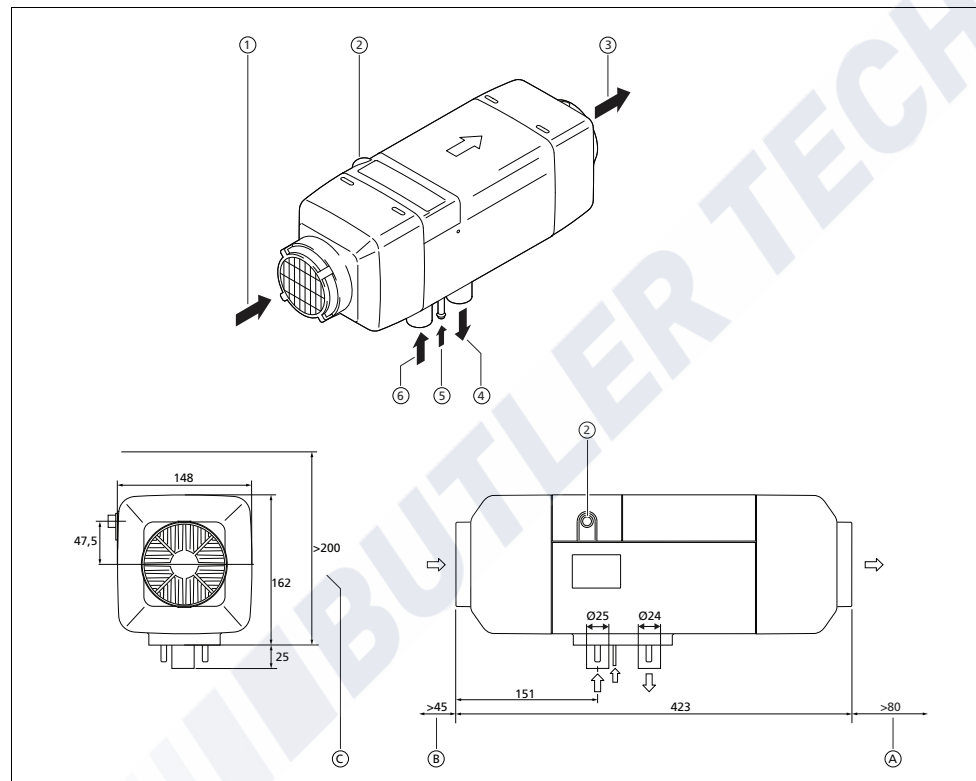

- ① Cold air inlet
- ② Cable outlet (optionally on right or left)
- ③ Hot air outlet
- ④ Exhaust gas outlet
- ⑤ Fuel inlet
- ⑥ Combustion air inlet
- A Space requirements for hot air outlet
- B Space requirements for cold air inlet
- C Space requirements for removing heater

Fig. 3 Dimensions and space requirements [mm] Air Top Evo 40 / Air Top Evo 55



4.2.2. Dimensions Air Top 2000 STC

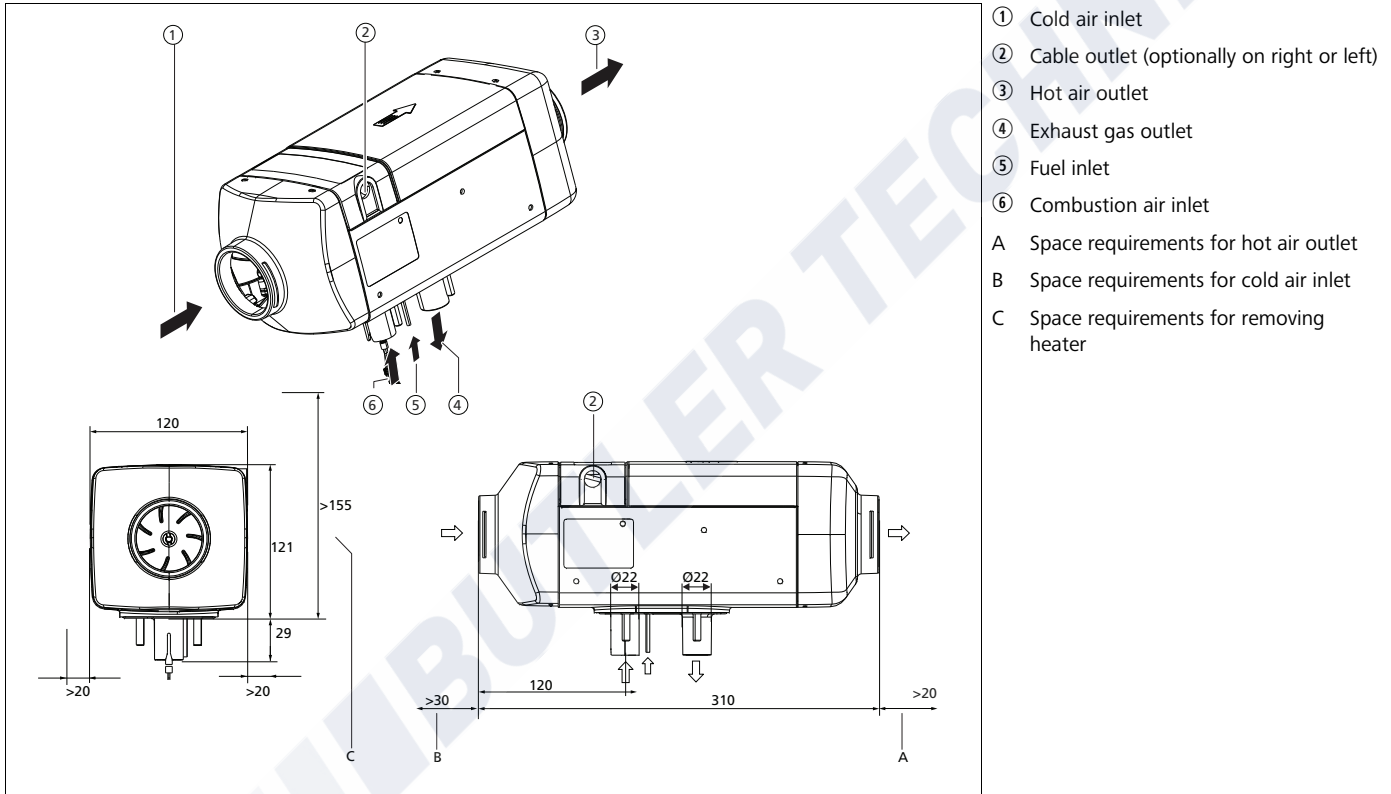

Fig. 4 Dimensions and space requirements [mm] Air Top 2000 STC

## Marine Air Heaters

### Air Top 2000 STC / Evo 40 / Evo 55

## Technical Information



#### ATTENTION:

##### Danger of drowning!

There is a danger of drowning when drilling into the boat's outer skin! Drilling below the water line can cause the boat to sink!

If the boat is in the water: check the drilling location! Have leak sealing equipment available beforehand and familiarise yourself with possible escape routes!



#### ATTENTION:

##### A blockage in the heating air rotor can cause the heater to overheat!

Damage to heater

- ▶ Make sure that the casing of the heater is clear, i.e. does not make contact with any other parts, in installed position (see Fig. 7).



#### NOTE:

- ▶ Installation positions: observe possible inclination of boat!
- ▶ Recommended installation position: exhaust gas outlet routed downward, heater parallel to longitudinal axis of boat.
- ▶ Do not install transversely in sailing boats!
- ▶ Exception: if heater is primarily operated when boat is moored or in motor boats then installation transverse to longitudinal axis is permissible.

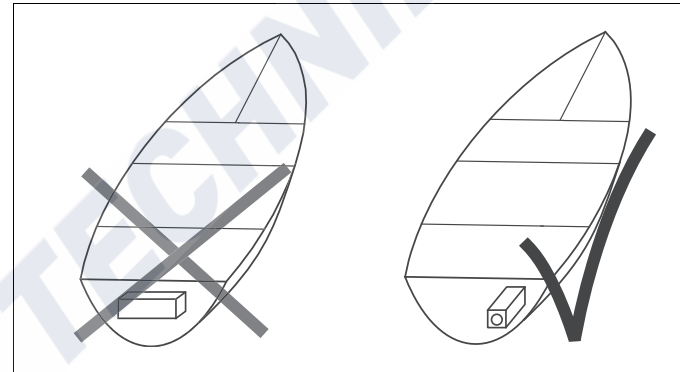

Fig. 5 Install heater in longitudinal direction in sailing boats!



## Technical Information

## Marine Air Heaters *Air Top 2000 STC / Evo 40 / Evo 55*

### 4.3. Heater mounting

- Securely mount the heater (vibration, swell)! Use the supplied bracket and rubber seal under the base.
- This rubber seal must be replaced each time the heater is reinstalled.
- The M6 nuts must be tightened to 6 Nm (-0 Nm, +1 Nm) to mount the base.

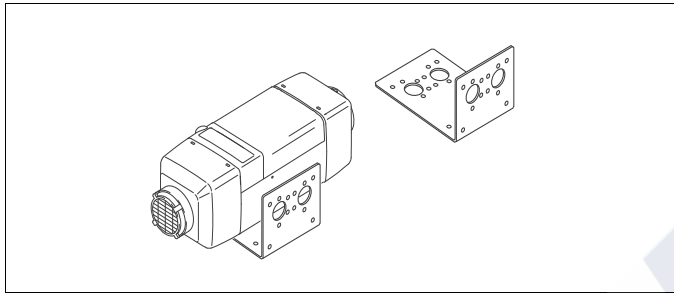

Fig. 6 *Mounting Air Top with bracket*



#### NOTE:

After installation check that the casing is not in contact with any part of the body. Failure to do this may result in the heating air fan blocking.

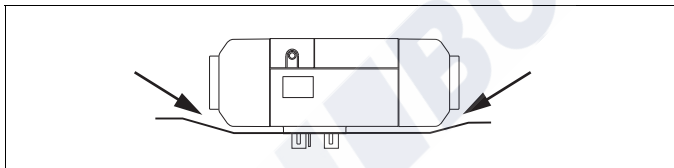

Fig. 7 *Ensure ease of movement of all moving parts!*

- Recommendation: flexible mounting (vibration decoupling, noise reduction)!
- Secure the heater onto the bracket with bolts.
- Recommendation when mounting on outer skin on FRP boats: laminate wooden panel onto the fastening location from the inside to prevent drilling through the outer skin.



#### ATTENTION:

**There is a danger of drowning when drilling into the boat's outer skin!**

Drilling below the water line can cause the boat to sink!

- ▶ If the boat is in the water: check the drilling location! Have leak sealing equipment available beforehand and familiarise yourself with possible escape routes!

- Determine space requirements and installation position
- Air Top 2000 STC:  
see Fig. 3 and Fig. 7
- Air Top Evo 40 / Air Top Evo 55:  
see Fig. 4 and Fig. 8
- Do not exceed inclination angle (see Fig. 8).



## Marine Air Heaters

### Air Top 2000 STC / Evo 40 / Evo 55

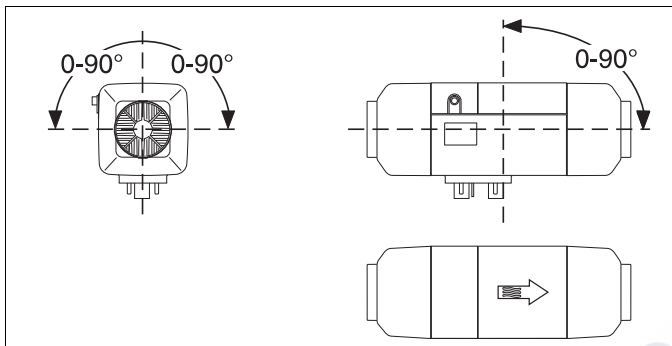

Fig. 8 Permissible installation positions of diesel-operated air heaters



#### ATTENTION:

The base seal must be replaced when removing and reinstalling a heater.

- Except for the year of installation, remove all the year numerals on the type label .
- Secure heater. Tighten the M6 nuts to 6 Nm (-0 Nm, +1 Nm).



#### NOTE:

After installing the heater, the type label should be clearly visible in a well-protected position.

- If the type label is not visible after installing the heater: use the type label duplicate.



## Cold and hot air

## Marine Air Heaters Air Top 2000 STC / Evo 40 / Evo 55

### 5 Cold and hot air

#### 5.1. General



#### **ATTENTION:**

#### **Danger of suffocation!**

*The cold air intake must be from a clean area with no exhaust gases.*

*Never from the engine compartment!*

It must not be possible for stowed articles to block the intake opening.



#### **NOTE:**

The direct intake of hot air must be avoided (see Fig. 9). It is not permitted to short-circuit the air flow.

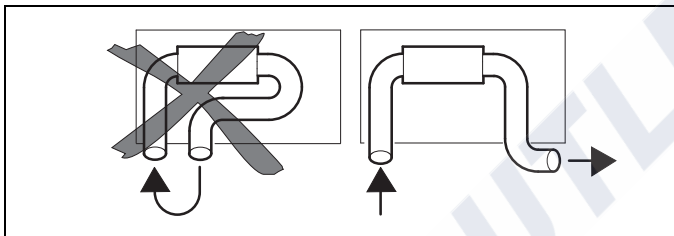

Fig. 9 Cold air inlet and hot air outlet

#### 5.2. Fresh air mode

Cold air is drawn in from the outside, heated and blown into the boat's interior. This renews the cabin air and reduces humidity. Ensure there are enough ventilation openings in the cabins! A room temperature sensor must be installed for temperature control, preferably in the saloon. In summer, ventilation is also possible (when comfort control element is used).

- ▶ Draw in cold air directly from lockers or rudder boxes if they are dry, clean and free of odours and exhaust gases.  
For proper ventilation, ensure the intake diameter = 1.5 x hose diameter of the heater.
- ▶ Otherwise, use an intake hose for intake from the outside.
- ▶ Prevent water from entering through the intake opening.

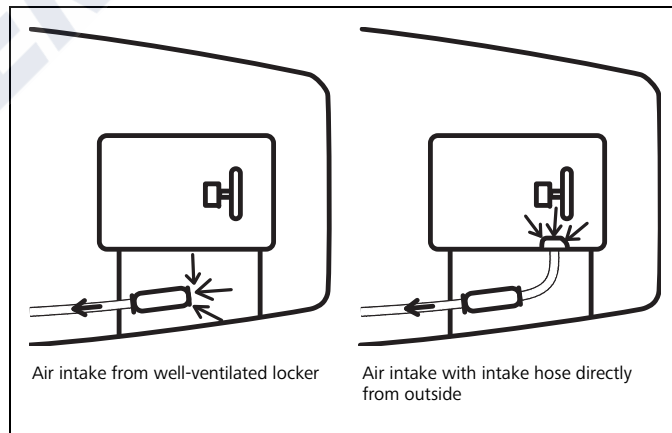

Fig. 10 Air intake

## Marine Air Heaters

### Air Top 2000 STC / Evo 40 / Evo 55

## Cold and hot air



#### NOTE:

For fresh air mode, a room temperature sensor must be installed in the cabins to be heated.

### 5.3. Recirculated air mode

In recirculated air mode, the air to be heated is taken from the interior area. The advantage of this is that heating takes place faster due to more effective heat utilisation. However, the humidity is not reduced or the room air not renewed in this mode.

No room temperature sensor needs to be installed. The heater uses the sensor integrated in the control unit.

### 5.4. Position of hot air openings



#### WARNING:

##### **Risk of injury!**

*Do not blow hot air directly onto living creatures or temperature-sensitive objects.*

All areas in the boat can be evenly heated with an appropriate air distribution system. For this purpose, branch off several side branches from the main line to reach all cabins. The air, and therefore the heat flow, can be influenced by suitable selection of the branches and hose diameters. See the accessories catalogue for branches, connecting elements, Y-junctions, air outlets, etc. made from temperature-resistant material.

- ▶ A free flow of air into the cabins provides the most effective cabin heating and air circulation!
- ▶ Only use one or two air outlets per cabin!

### 5.5. Properties of cold and hot air ducts

Recommended inside diameter of main hot air duct:

- 60 mm for Air Top 2000 STC
- 80 mm for Air Top Evo 40
- 90 mm for Air Top Evo 55



#### NOTE:

Only materials with a thermal resistance of 130 °C (short-term 150 °C) are to be used for the hot air duct.

### 5.6. Layout of cold and hot air ducts



#### ATTENTION:

##### **Use without cold air intake hose**

Risk of injury by rotating heating air rotor

- ▶ If used without the cold air intake hose, install the supplied mesh guard over the intake

Maximum differential pressure between intake and pressure side of heater:

- Air Top 2000 STC: 2.0 hPa
- Air Top Evo 40: 2.0 hPa
- Air Top Evo 55: 3.0 hPa



#### ATTENTION:

The heating output will be reduced if this pressure differential is exceeded.





## Cold and hot air

## Marine Air Heaters Air Top 2000 STC / Evo 40 / Evo 55

### 5.7. Installing cold and hot air ducts

- ▶ Do not route the ducts through the bilge.
- ▶ Hot air ducts in damp areas: use temperature-resistant, flexible, metal spiral-reinforced plastic hoses.
- ▶ Secure cold and hot air ducts at all connections.
- ▶ In stowage areas:  
Use a perforated metal cover, for example, to protect the ducts from damage by cargo.
- ▶ Recommended:  
Routing through bulkheads:  
Use wall lead-through as shown in Fig. 11.  
See the Webasto accessories catalogue.
- ▶ Secure ducts:
  - With hose clips at all connecting elements.
  - Prevent from chafing, see Fig. 12.
- ▶ Recommendation  
for routing hoses through area not to be heated: insulate the hose sections to prevent heat loss.

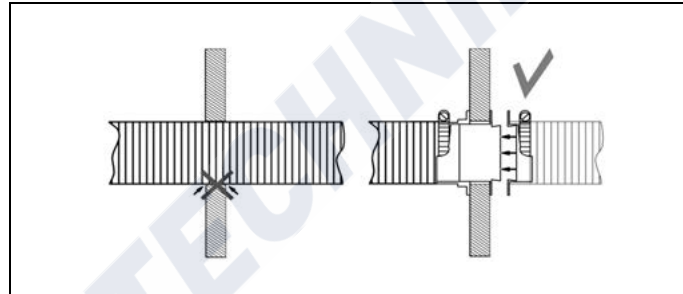

Fig. 11 Recommended duct lead-through in bulkheads

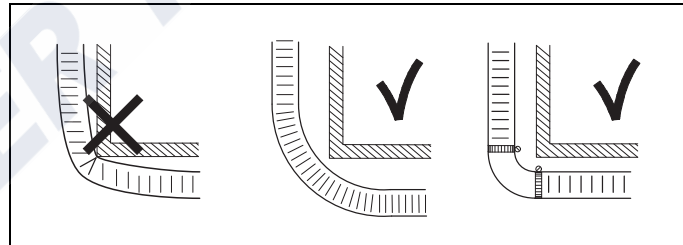

Fig. 12 Recommended routing around corners

## Marine Air Heaters

### Air Top 2000 STC / Evo 40 / Evo 55

Cold and hot air



#### 5.8. Silencer in air duct

Recommendation: For Air Top 2000 STC / Evo 40 / Evo 55 units with short air duct, use silencer on intake and/or outlet side (reduction in noise level). See the accessories catalogue.

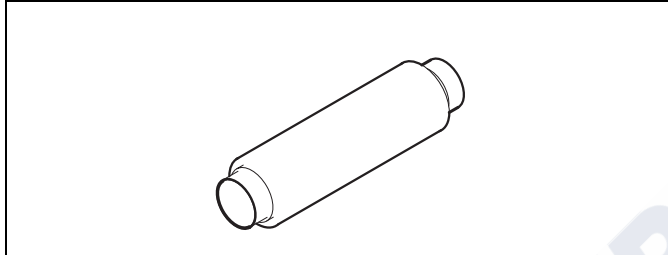

Fig. 13 Silencer for reducing noise level

#### 5.9. Air routing examples

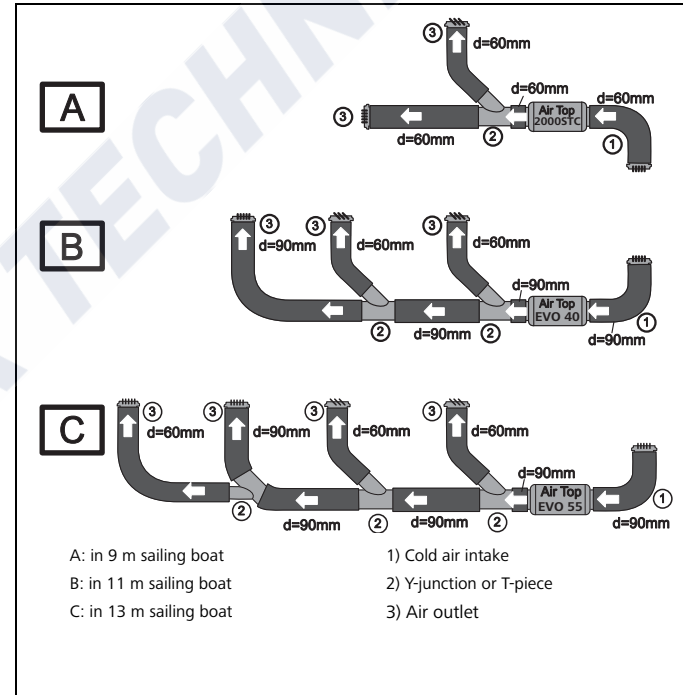

Fig. 14 Heating air routing examples

The main duct must not be reduced from 90 to 80 mm for Air Top Evo 55!

If 90 mm is not possible throughout, it is better to use Y-junction 90/80/80 and thus create two 80 mm main ducts.



## Cold and hot air

## Marine Air Heaters Air Top 2000 STC / Evo 40 / Evo 55

### 5.10. Installation examples:

#### 37' sailing boat

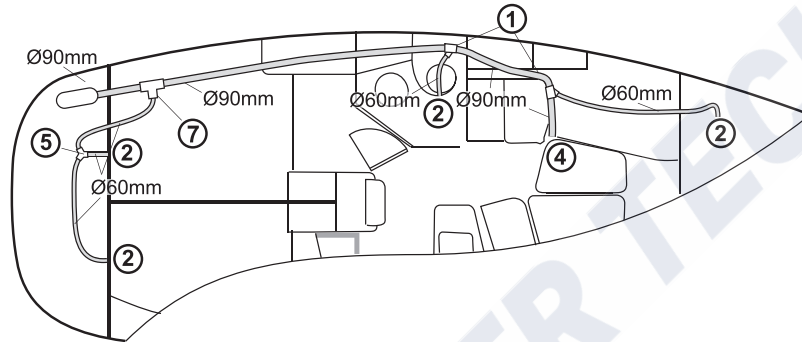

- ① Branch 90/60/90
- ② Air outlet Ø 60 mm, can be closed off
- ③ Y-junction 90/90/90
- ④ Air outlet Ø 90 mm, open
- ⑤ Y-junction 60/60/60
- ⑥ Air outlet Ø 90 mm, can be closed off
- ⑦ T-piece 90/60/90

#### 43' sailing boat

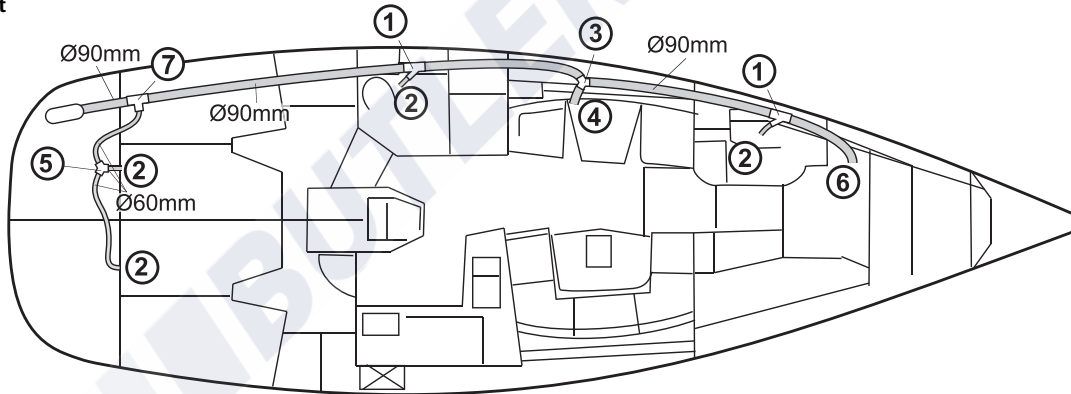

Fig. 15 Installation examples



## Marine Air Heaters

### Air Top 2000 STC / Evo 40 / Evo 55

## 6 Fuel supply

### 6.1. General



**ATTENTION:**  
**Danger of fire!**

If the heater takes the fuel from a separate additional tank, the fuel type and the filler neck must be clearly marked.

- ▶ The fuel filler neck must not be located in the interior of the boat and must be fitted with a well-sealing cap to prevent fuel from escaping.
- ▶ Protect the boat hull/components in the vicinity of the heater from heat/contamination by fuel/oil!



**NOTE:**

- Fuel take-off must take place with virtually no pressure.
- If taking fuel from the return line make sure that the line is not blocked by non-return valves.

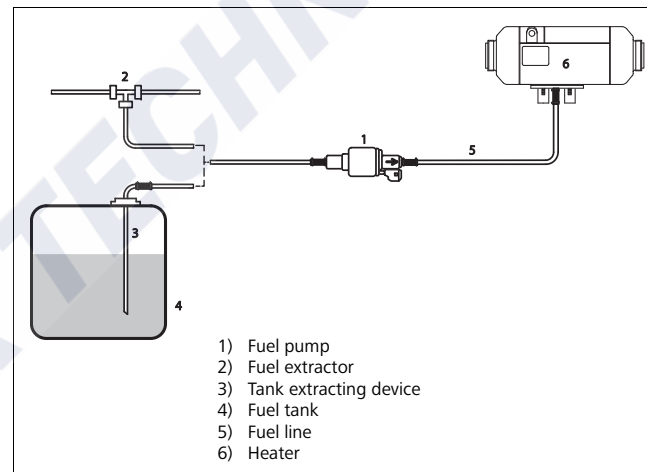

Fig. 16 Example of fuel supply Air Top heaters

### 6.2. Fuel extraction

The following alternatives are available for extracting fuel for the heater:

#### 6.2.1. Tank extracting device

- Fuel take-off directly from the boat's fuel tank.
- Plastic fuel tanks: install the tank extracting device in the tank fitting. Do not drill into a plastic fuel tank.
- For suitable tank extracting device for metal tanks see the accessories catalogue or scope of delivery.



## Fuel

## Marine Air Heaters *Air Top 2000 STC / Evo 40 / Evo 55*

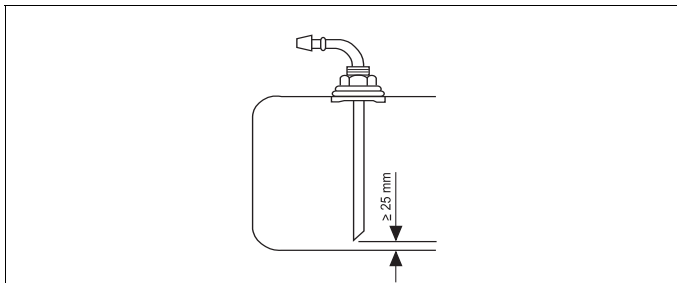

Fig. 17 Installing a tank extracting device in metal tank

### 6.3. Fuel extractor

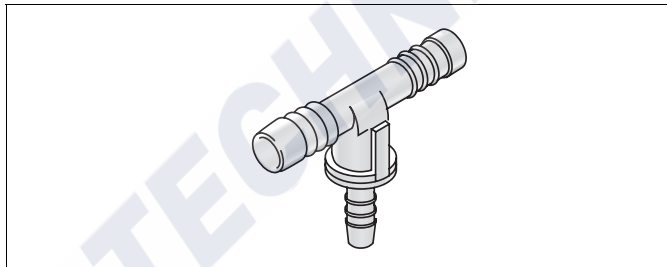

Fig. 18 Fuel extractor

Install the tank extracting device as shown in Fig. 17:

- 1) Shorten the immersion tube: the end should be approx. 25 mm above the bottom of the tank or high enough that fuel for the boat engine always remains in the tank. Cut the tube diagonally. Deburr the cut edges.
- 2) Drill a hole in the tank or tank fitting from above. Use suitable drilling attachment. Grease the drill bit and drilling surface beforehand (to catch small drilling chips).
- 3) Fit the tank fitting into the hole and screw tight (the seal is slightly compressed).

#### 6.2.2. Fuel take-off coupling

If there is an unused fuel take-off coupling already fitted in the boat's fuel tank then use it.

Do not take fuel from the drain plug at the bottom of the tank as dirt or water can be drawn in from the drain.

The fuel extractor is a special T-piece with an integrated bubble separator. It can be installed in the supply line to the engine if no pre-supply pump is installed in the fuel tank or in the return line from the engine if it almost reaches the bottom of the fuel tank. Take into account the diameters of the installed pipes when selecting the fuel extractor.

See the Webasto accessories catalogue for a suitable fuel extractor.

### 6.4. Pipe lengths and delivery head

When installing the fuel line make sure that it is kept as short as possible.

See Fig. 19.

The pipe must be installed such as to protect it from being damaged.

The fuel line must be installed in cool areas to avoid bubbles being formed by the effect of heat. High fuel temperatures can cause the heater to malfunction.

Marine Air Heaters

Air Top 2000 STC / Evo 40 / Evo 55

Fuel

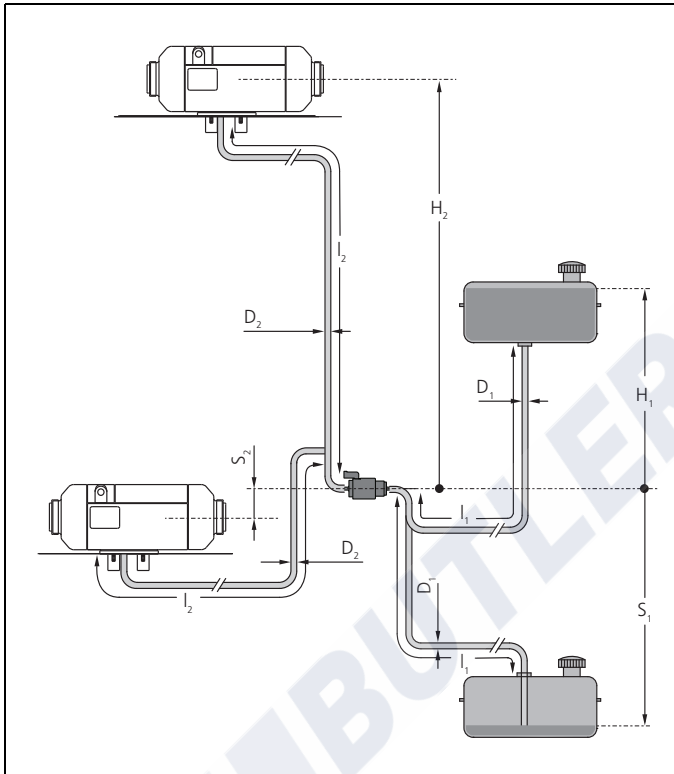

Fig. 19 Fuel supply

The fuel lines must be secured using state-of-the-art fastening elements. Do not damage the fuel line.

Intake side:

$D_1$ : Inside diameter of fuel line = 2 mm.

$H_1$ : Fuel level (tank above fuel pump) [m]

$S_1$ : Fuel level (tank below fuel pump) [m]

$l_1$ : Length of fuel line [m]

Pressure side:

$D_2$ : Inside diameter of fuel line = 2 mm.

$H_2$ : Height difference between heater and fuel pump (heater above fuel pump) [m]

$S_2$ : Height difference between heater and fuel pump (heater under fuel pump) [m]

$l_2$ : Length of fuel line [m]

Fuel level (tank above fuel pump) $H_1$ [m]	Maximum permissible fuel pressure at take-off point, $p_1$ [bar]
$H_1 = 0$	$-0.1 < p_1 < +0.5$
$0 < H_1 < 1$	$-0.1 < p_1 < +0.4$
$1 < H_1 < 2$	$-0.1 < p_1 < +0.3$

Fuel level (tank below fuel pump) $S_1$ [m]	Maximum permissible fuel pressure at take-off point, $p_1$ [bar]
$0 < H_2 < 1.3$	$-0.1 < p_1 < +0.5$



## Fuel

## Marine Air Heaters Air Top 2000 STC / Evo 40 / Evo 55

Parameter	Value
Length of intake pipe $l_1$ [m]	max. 5
Length of pressure pipe $l_2$ [m]	max. 10
Length of intake pipe $l_1$ + length of pressure pipe $l_2$ [m]	max. 12
Height difference between heater and fuel pump (Heater above fuel pump) $H_2$ [m]	max. 3
Height difference between heater and fuel pump (Heater below fuel pump) $S_2$ [m]	max. 1

### 6.4.1. Pipe material

Only use steel or plastic fuel lines made from light and temperature-resistant PA11 or PA12 (e.g. Mecanyl-RWTL) in accordance with DIN 73378 as the fuel pipes.

### 6.4.2. Connecting 2 fuel lines to a hose

Fig. 20 shows the correct connection of fuel lines to a hose. Make sure there are no leaks!

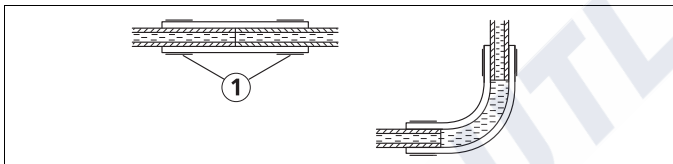

Fig. 20 Pipe/hose connection

1) Fuel pipe connection

Fuel line material (metal/plastic): observe regional/national regulations!



### ATTENTION: Danger of fire!

- The fuel lines in the engine compartment must be made of metal and the connecting hoses between the individual components of fire-resistant material (as per DIN EN ISO 7840)!
- If the fuel pump is equipped with a plastic fuel damper (e.g. Air Top 2000 STC Diesel) it must be protected with a protective sleeve (see accessories catalogue) when installed in the engine compartment.
- Only use fire-resistant fuel filters in accordance with ISO 7840 for installation in the engine compartment.

For installation kits for metal fuel lines see the accessories catalogue.

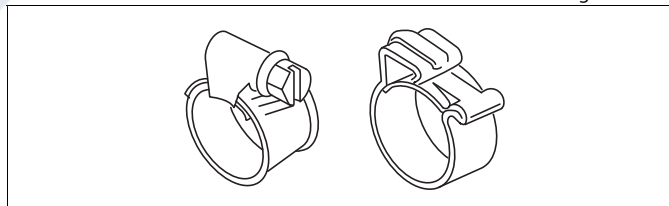

Fig. 21 Stainless steel hose clips

## Marine Air Heaters

### Air Top 2000 STC / Evo 40 / Evo 55

## Fuel



#### NOTE:

- Only use stainless steel hose clips to secure plastic lines.
- Metal pipes: ensure cleanliness and neatness while carrying out the work! Remove all soiling and burrs from the connection points prior to assembly!
- Do not overtighten union nuts (otherwise leaks may occur).
- Route the fuel lines as straight as possible and at a slight incline so that air bubbles escape towards the heater.
- Secure the line at regular intervals to prevent sagging, avoid kinks.
- Keep away from heat sources. Use heat shield if necessary!
- Inside  $\varnothing$  of fuel line = 2 mm, larger diameters will cause problems due to gas bubbles.

- Check the direction of flow of the pump.  
For permissible ambient temperature see Chapter 13, "Technical Data".

#### 6.5. Fuel pump

Air Top 2000 STC, Air Top Evo 40 and Air Top Evo 55 heaters must only be operated with the DP 42 fuel pump.

The fuel pump is a combined delivery, metering and a shut-off system and is subject to certain installation criteria (for installation position see Fig. 22 (DP42)).

The fuel pump is controlled with a separate wiring harness and feeds the fuel into the combustion chamber of the heater depending on the required heating capacity. Due to the individual delivery strokes, the separate fuel pumps make a ticking noise during operation.

##### 6.5.1. Installation location

The fuel pump must not be installed within the radiated head range of hot components. Fit a heat shield if necessary. The fuel pump should be preferably installed close to the fuel tank.

- Install the pump in a dry/cool area. Do not install in the bilge.





## Fuel

## Marine Air Heaters Air Top 2000 STC / Evo 40 / Evo 55

### 6.5.2. Installation and attachment

The installation position is restricted (maximum inclination angle and axial installation position of fuel pump) as illustrated in Fig. 22. The arrow shows the direction of flow.

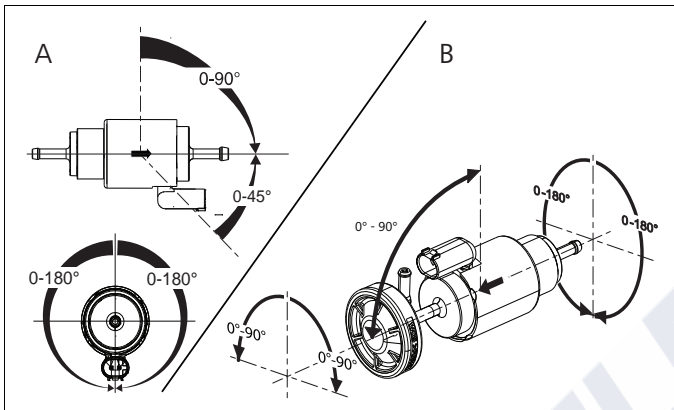

Fig. 22 DP 42 fuel pump installation position  
A: Version without diaphragm damper\*  
B: Version with diaphragm damper\*

\*: Dependent on scope of delivery

Use the flexible mount to install the fuel pump (reduces the transmission of structure-borne noise/ticking)! See Fig. 23.

Version B: Position of fuel pump 0-180°, diaphragm 0-90°

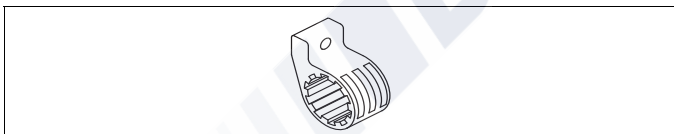

Fig. 23 Flexible mount of fuel pump



#### NOTE:

Recommended installation: mount on solid and sturdy part of boat.

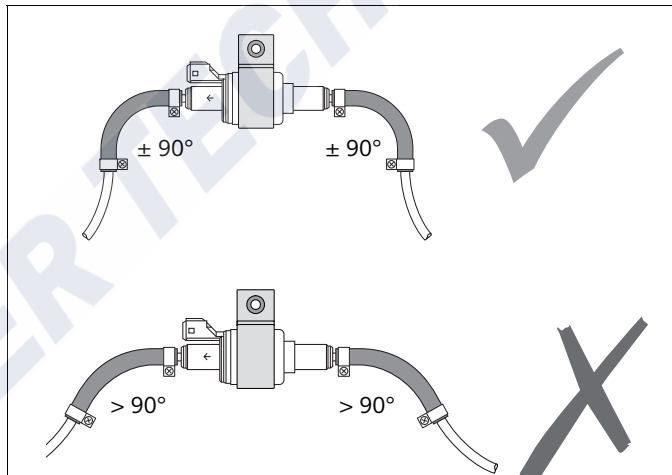

Fig. 24 Fuel line mounting

- Attaching the 90° bends included in the scope of delivery to the intake and pressure side of the fuel pump decouples the pump from the fuel line. This reduces the transmission of structure-borne noise and thus the noise level.
- Lay the fuel line such that the 90° bends are not stretched; see Fig. 24.



#### ATTENTION:

The 90° bends are not fire-resistant to ISO 7840 and are therefore not suitable for installation in the engine room.



### 6.6. Fuel filter

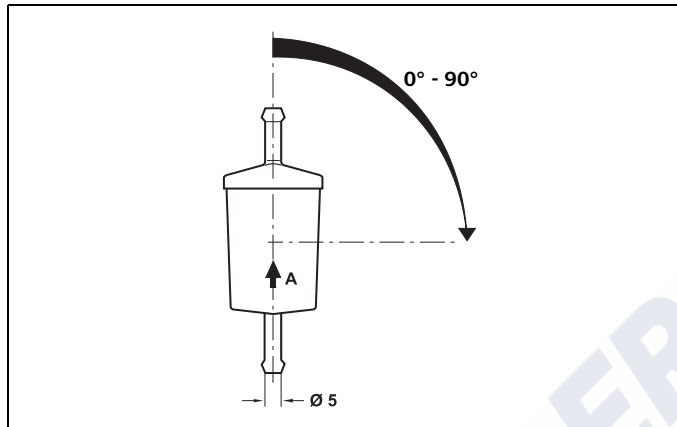

Fig. 25 Fuel filter, installation position and direction of flow

Install a suitable fuel filter (e.g. Webasto fuel filter) if dirty fuel is to be expected. Wherever possible install vertically, deviating by no more than 90° (see Fig. 25).



**NOTE:**

Pay attention to installation position and direction of flow.

### 6.7. Auxiliary tank



**ATTENTION:**

If an auxiliary tank is required for the fuel supply to the heater: It must only be installed by a specialist company for marine applications (with the necessary knowledge of the required standards, regulations and directives)!

### 6.8. Special requirements for heaters in boats with petrol engine



**ATTENTION:**

Petrol-operated heaters are not permitted in recreational boats covered by ISO 9094. Local regulations and special safety requirements must be complied with.

### Specific requirements apply to the installation of diesel-operated heaters in petrol engine boats:

- The heater must be supplied with fuel from a separate diesel tank which must comply with the valid regulations for diesel tanks in boats.
- Do not install heaters wherever flammable petrol vapours can form, i.e. especially in engine compartments, fuel tank compartments and rooms directly annexed to them.
- The combustion air intake must come from the outside and not from the engine compartment!
- Do not route exhaust pipes through engine or tank compartments.



## Combustion air

## Marine Air Heaters *Air Top 2000 STC / Evo 40 / Evo 55*

### 7 Combustion air supply

#### 7.1. Combustion air intake line

- ▶ Combustion air intake line: must be arranged that it cannot be blocked by objects
- ▶ Keep combustion air intake line as short as possible
- ▶ Mounting of combustion air intake line: with a hose clip at the intake connection piece of the heater and with pipe clamps or cable ties on fixed built-in components.

#### 7.2. Combustion air intake from a well-ventilated area (locker, stowage compartment or engine compartment)

- ▶ No through-hull fitting required
- ▶ The intake area must be at ambient pressure and sufficiently ventilated to the outside!
- ▶ Intake from engine compartment: the ventilation fan in the engine compartment must not produce an overpressure or negative pressure in the engine compartment.
- ▶ Intake point: no intake of exhaust gases from heater or engine!
- ▶ Fit a cap over the end of the hose to prevent water ingress (if no through-hull fitting is used).

#### 7.3. Combustion air intake directly from outside

- ▶ Use a separate through-hull fitting if intake from a ventilated area is not possible.

- ▶ Arrange the end of the combustion air intake line as a gooseneck, as illustrated. Prevent water from entering through the intake opening.
- ▶ Do not position the through-hull fitting in the direction of travel (otherwise backpressure and water ingress may occur in the intake pipe).

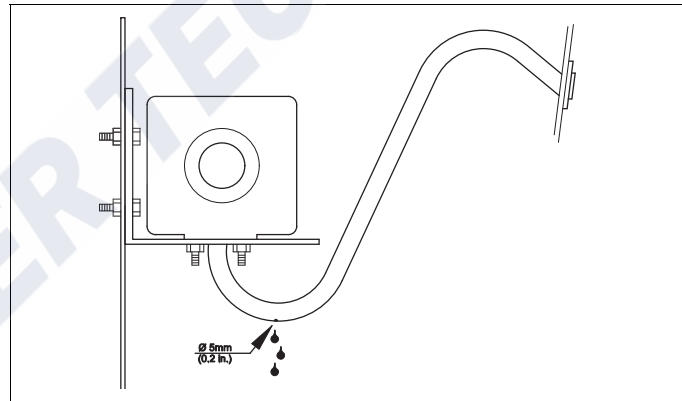

Fig. 26 Combustion air intake line not in direction of travel

- ▶ Drill a drain hole at the lowest point as illustrated in Fig. 26.
- ▶ Route hose free of kinks.



#### NOTE:

A combustion air intake line is required.  
A minimum length is not specified.

## Marine Air Heaters

### Air Top 2000 STC / Evo 40 / Evo 55

## Combustion air



**NOTE:**

The combustion air intake line with silencer must not exceed a max. length of 2.0 m.

#### 7.5. Combustion air intake silencer



**NOTE:**

A combustion air intake silencer must be installed if the length of the combustion air intake line is less than 0.5 m.

#### 7.4. Properties of combustion air intake line



**ATTENTION:**

**The exhaust pipe can be confused with the combustion air intake line!**

Damage to fuel pump cable

- ▶ Fit the exhaust pipe only to the exhaust outlet socket coupling
- ▶ Do not use a metal combustion air intake line

Combustion air intake line		Value
Inside diameter	Air Top 2000 STC	22 mm
	Air Top Evo 40 / Air Top Evo 55	25 mm
Smallest bend radius		50 mm
Max. sum of all bends		270°



## Exhaust gas

### 8 Exhaust system

#### 8.1. General

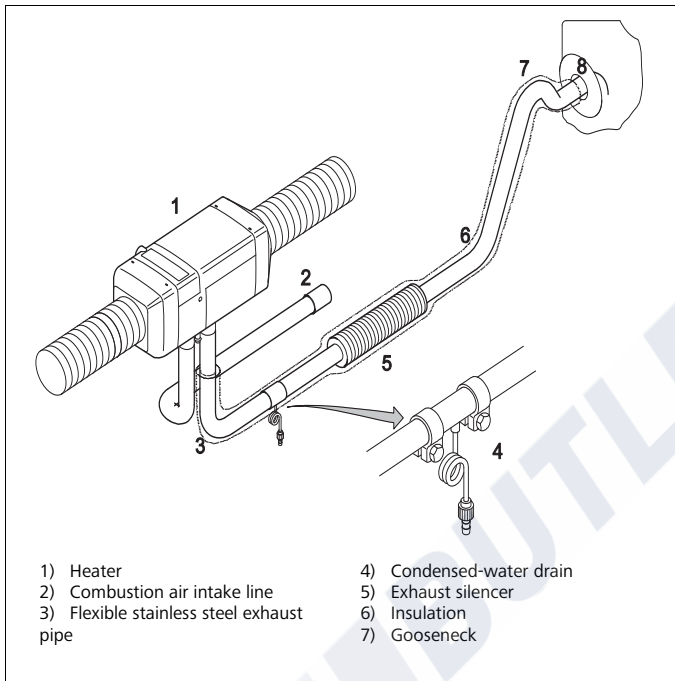

Fig. 27 Exhaust system

#### 8.2. Exhaust gas outlet



**ATTENTION:**  
**Generation of heat by incorrect positioning of exhaust pipe outlet!**  
Injuries or damage to property caused by fire  
▶ Pay attention to installation position.

#### Outlet arrangement:

- ▶ Position the exhaust gas outlet where no splash water can enter the boat.  
Recommendation:  
Sailing boats: in stern transom.  
Motor boats: in side wall.



**ATTENTION:**  
**Danger of suffocation!**  
*Do not position the exhaust gas outlet below or next to ventilation equipment, window openings or the heating air inlet*

- ▶ At least 60 cm above the water line so that no water can enter when the boat is heeling
- ▶ Not in direction of travel of the boat (high wind pressure)
- ▶ Do not connect to engine or generator exhaust system (higher pressures; damage to heater!)
- ▶ Not where it can be easily covered, e.g. by fender.

## Marine Air Heaters

### Air Top 2000 STC / Evo 40 / Evo 55

Exhaust gas



#### Through-hull fitting:

- ▶ Choice of design and installation position to minimise rain water ingress!
- ▶ Only use genuine Webasto through-hull fittings! Fit insulation plate exactly for thermal isolation from the side wall (minimisation of water ingress)! If additional sealing is required: use only heat-resistant sealing compound!
- ▶ Through-hull fitting: cannot be closed; not with self-opening flaps!
- ▶ Mount through-hull fitting with pipe socket angled upward.

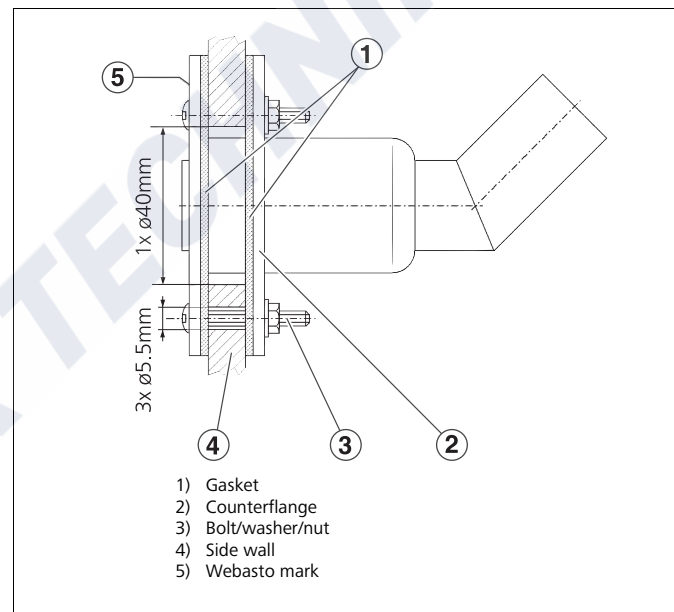

Fig. 28 Through-hull fitting



#### NOTE:

Avoid drawing in exhaust gas with the combustion air.



## Exhaust gas

## Marine Air Heaters Air Top 2000 STC / Evo 40 / Evo 55

### 8.3. Notes on exhaust pipe

The exhaust pipe must be secured to the heater with a clamp suitable for the exhaust pipe.

Use suitable insulation material to avoid the dew point dropping below the minimum value.

- ▶ Keep exhaust pipe as short as possible.
- ▶ No contact with temperature-sensitive objects such as electrical wiring, water lines, plastic parts, sails or boat hull!

### 8.4. Length of exhaust pipe and combustion air intake line

For the Air Top 2000 STC / Evo 40 / Evo 55, the following maximum total lengths of the combustion air intake line and exhaust pipe must be complied with:

- With exhaust silencer: max. 2.5 m
- Without exhaust silencer: max. 5.0 m.

### Properties of exhaust pipe



#### ATTENTION:

**The exhaust pipe can be confused with the combustion air intake line!**

Damage to fuel pump cable

- ▶ Fit the exhaust pipe only to the exhaust outlet socket coupling

Exhaust line	Value
Max. sum of all bends	270°
Minimum length	0.5 m

### Exhaust silencer

Use the genuine Webasto exhaust silencer provided! It considerably reduces noise. There are no restrictions in terms of installation position and direction of flow.

Do not drill a condensation drain hole in the silencer (this will cause exhaust to escape)!

To prevent impermissible vibration, the exhaust silencer itself must be secured with a clip to fixed parts of the boat at 50 cm intervals.

The heater can also be operated without a silencer.

For suitable models see the Webasto accessories catalogue.

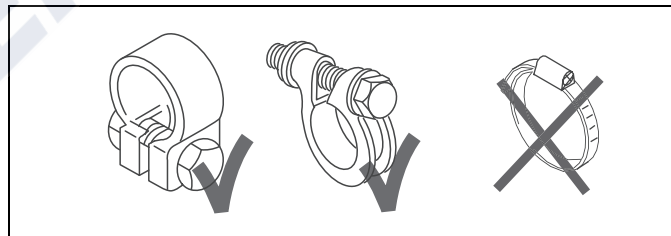

Fig. 29 Approved hose clamps for mounting exhaust pipes

Exhaust line	Value
Inside diameter	Air Top 2000 STC: 22 mm
	Air Top Evo 40 / Air Top Evo 55: 24 mm
Smallest bend radius	50 mm



## Marine Air Heaters

### Air Top 2000 STC / Evo 40 / Evo 55

#### Condensed-water drain

Fit a condensed-water drain (non-rusting) if the exhaust pipe is longer than 2 m!

- A) With a T-piece at the lowest point in the exhaust pipe or
- B) If the heater itself is at the lowest point: use an exhaust connection piece with an integrated condensed-water drain.  
For suitable components see the Webasto accessories catalogue.

Use a container or drain hose to collect the condensation water.

Different versions of the condensed-water drain fitting are available.

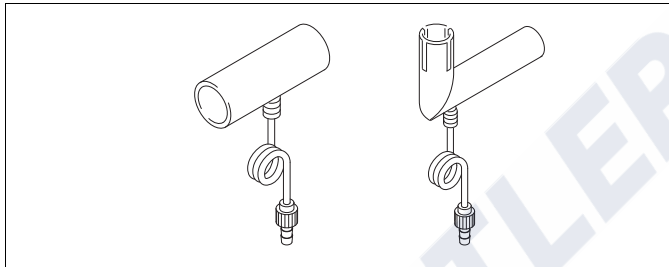

Fig. 30 Condensed-water drain fitting

#### 8.5. Thermal insulation

Observe the following points when installing the exhaust pipe:

- ▶ Avoid contact between the hot exhaust pipe and temperature-sensitive objects such as electrical wiring, water lines, plastic parts, sails or boat hull!
- ▶ If contact with persons/objects is possible during heating: Insulate the exhaust pipe or fit contact barrier! For suitable exhaust insulation materials see the Webasto accessories catalogue.



Fig. 31 Exhaust pipe insulation sheathing

- ▶ Surface temperature  $\leq 80$  °C!
- ▶ Minimum distance from walls  $\geq 20$  mm.

#### 8.6. Gooseneck

Last section of exhaust pipe: gooseneck sloping downward to the outlet (due to possible ingress of water)!

Height of gooseneck:  $\geq 20$  cm.





### 9 Electrical Connections

The free ends of all lines that are not required must be insulated!

#### 9.1. Electrical system, general

- Observe all information and safety precautions!
- Install a clearly visible operating indicator to show whether the heating is switched on or off. This is already integrated in the Webasto control elements.
- Install all wiring harnesses and electrical components in dry and protected areas!
- The free ends of all lines that are not required must be insulated.
- If there is highly sensitive electronic equipment on board, special electrical interference suppression measures may be necessary. Contact an authorised Webasto partner.
- Do not touch exposed PCBs of the unit (electrostatic discharge).
- For connector designations, see the legend and wiring diagrams, Page 89.

#### 9.2. Wiring harnesses

Fig. 32 and Fig. 33 show the wiring harnesses for Air Top 2000 STC and Air Top Evo 40 / Air Top Evo 55

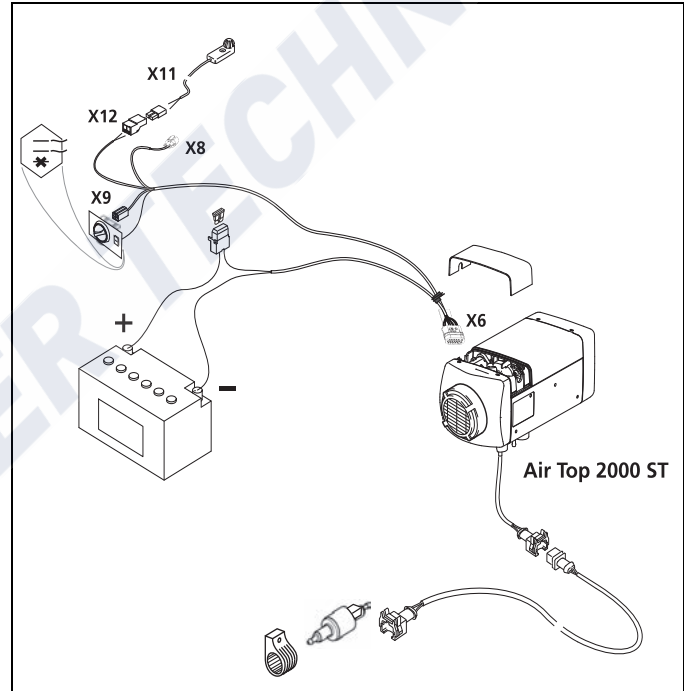

Fig. 32 Wiring harness Air Top 2000 STC



## Marine Air Heaters

### Air Top 2000 STC / Evo 40 / Evo 55

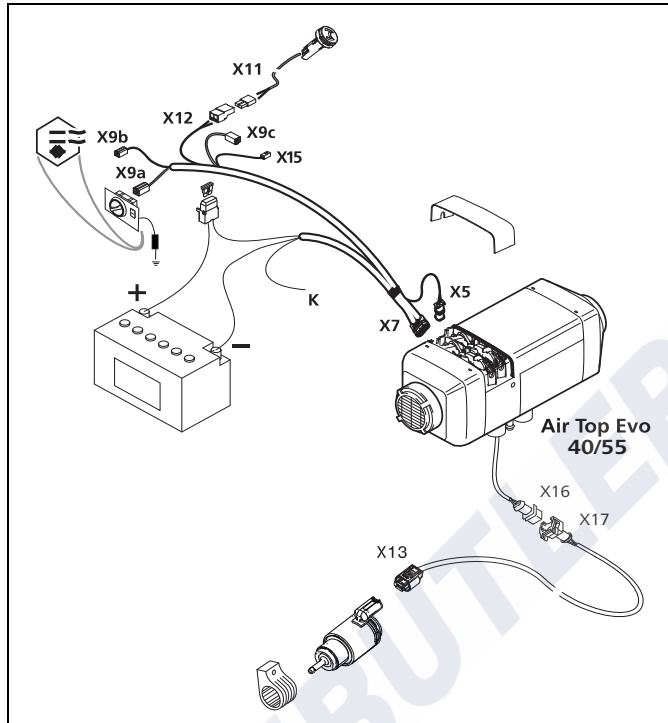

Fig. 33 Wiring harness Air Top Evo 40 / Air Top Evo 55

### 9.3. Connecting heater

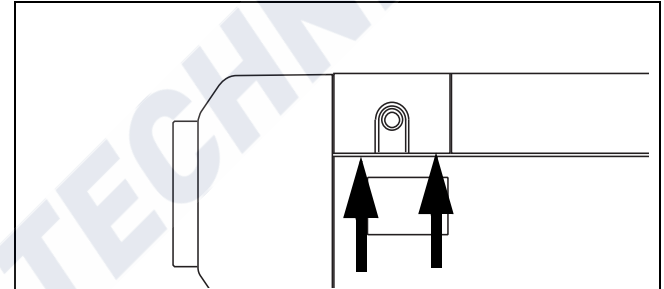

Fig. 34 Removing control unit cover



**NOTE:**

Use a blunt blade on both sides to remove the control unit cover (Fig. 34 arrows).

To connect the heater, remove the control unit cover on the heater and plug in the wiring harness connector at the control unit.



## Electrical system

## Marine Air Heaters Air Top 2000 STC / Evo 40 / Evo 55

The X6 connector for the Air Top 2000 STC must be plugged in as far as point "a".

The connector X7 for the Air Top Evo 40 / Air Top Evo 55 must be connected to the heater. See Fig. 35.

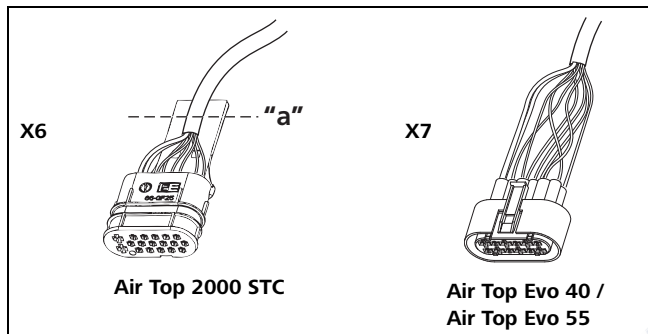

Fig. 35 Connector to heater control unit

### 9.3.1. Only for Air Top Evo 40 / Air Top Evo 55:

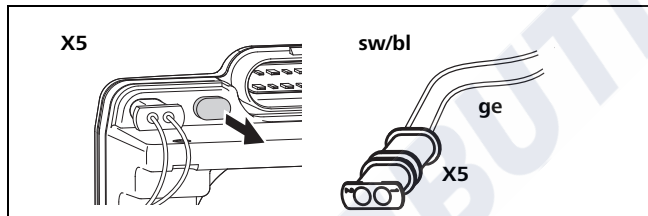

Fig. 36 Plugging in room temperature sensor at control unit

See Fig. 36 and wiring diagrams Air Top Evo 40 / Air Top Evo 55: Remove and dispose of the protective cap on the control unit. Plug connector X5 of the wiring harness for the room temperature sensor into this socket.

To ensure that the cable duct in the control unit cover is thoroughly sealed, the cable grommet should be positioned appropriately on the wiring harness.

Route the wiring harness out of the heater on the left- or right-hand side and place the cover on top.

The heater must not be operated without the control unit cover (this will cause the heater to overheat).

### 9.4. Power supply



#### ATTENTION:

To enable afterrunning, the heater must not be shut down (disconnected from the power supply).

- Power supply to heater: from the boat's service battery (not the starter battery for the engine due to risk of discharge). Connect the red cable to the "+" terminal of the battery. This connection should always be made before the main switch to enable heater afterrunning. Connect the brown cable to earth directly at the battery.
- The wiring harness for the Air Top Evo 40 / Air Top Evo 55 includes cable K (Fig. 33, colour rt/sw) for optional control of a battery disconnector or an additional operating indicator.



#### NOTE:

Strip or tie back cable ends in the wiring harness that are not needed.

- Keep power supply cables as short as possible. Shorten the cables if necessary.
- Cross section of connection cables:  $\geq 4.0 \text{ mm}^2$ .  
If cable lengths  $> 7.5 \text{ m}$ :  $\geq 6.0 \text{ mm}^2$
- When extending cables, make sure the total cross section is adequate and the insulation matches.



## Marine Air Heaters

### Air Top 2000 STC / Evo 40 / Evo 55

- The heater must be protected with a fuse (F1).  
F = 20 A (12 V)  
F = 15 A (24 V)
- If control elements other than the rotary switch are to be connected, a 1A fuse (F3) should be fitted in the fuse holder.
- The fuse must be installed splash water-protected in the interior.
- Distance of the main fuse from the "+" battery terminal: ≤ 1 m

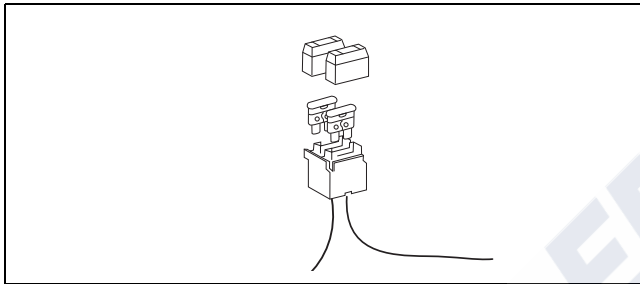

Fig. 37 Fuse holder on wiring harness

### 9.5. Temperature control

Install a room temperature sensor in the boat's interior (mandatory for fresh air mode)!

The heater continually compares the set temperature (value set at the control element) and the actual temperature (measured at the room temperature sensor) and automatically adjusts the heating capacity.



#### ATTENTION:

The Air Top heater is a separate system that operates independently of the engine with integrated temperature control.

An additional automatic control system for the purpose of controlling the temperature is not permitted.

#### 9.5.1. Installing room temperature sensor

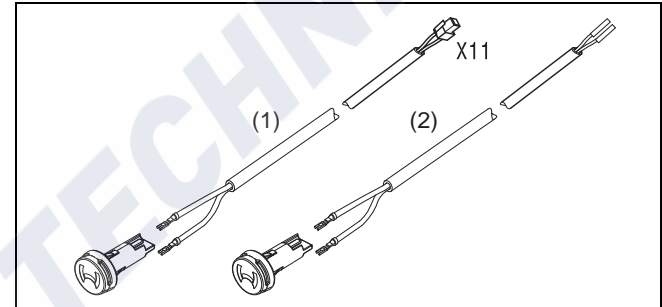

Fig. 38 Room temperature sensor for registering interior temperature  
(1) Air Top Evo 40 / Air Top Evo 55;  
(2) Air Top 2000 STC

Mount the sensor in a favourable/suitable position in the room to be heated. The distance to the control element is ≤ 2.5 m due to the cable length. Use a room temperature sensor with a 5 m long cable for greater distances, see the Webasto accessories catalogue.

The position has a decisive effect on the control characteristics!



#### NOTE:

- In largest cabin to be heated
- In position at average room temperature
- At half the room height if possible
- On a vertical interior wall if possible, not directly on an outside wall
- Not in the air flow of hot air outlets
- Not within the range of the companionway
- Not in the vicinity of heat sources
- Not behind cushions or curtains
- Not in direct sunlight



## Electrical system

## Marine Air Heaters *Air Top 2000 STC / Evo 40 / Evo 55*

### Air Top 2000 STC:

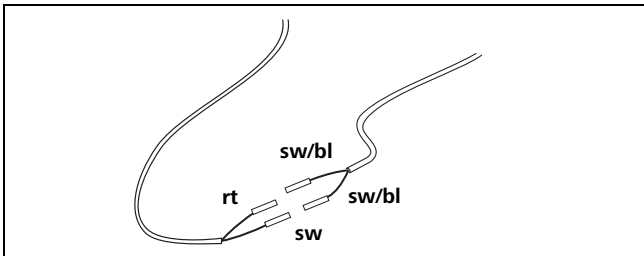

Fig. 39 Wiring of room temperature sensor

See Fig. 39 and wiring diagrams.

### Air Top Evo 40 / Air Top Evo 55:

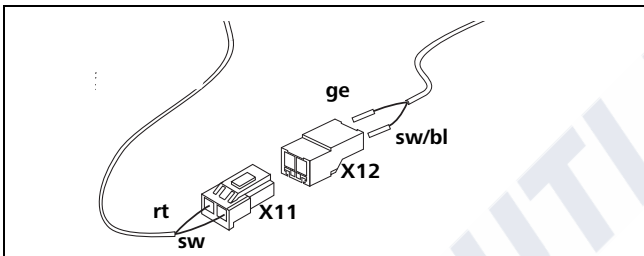

Fig. 40 Wiring of room temperature sensor

See Fig. 40 and wiring diagrams:

- Fitting connector X11.
- Attach X12 connector to the cable.

Attach X11 connector to X12.

### 9.6. Control elements

It switches the heater ON/OFF and defines the setpoint for the interior temperature.

Position: mount in the interior such that it is easily accessible, visible and protected from water. The position has no effect on the control characteristics!

Various control elements with different functions are available, see the accessories catalogue.



#### NOTE:

Only pull on the connector housing to unplug the connector.

The connector housing will lock (self-locking action) by pulling on the wiring harness.



## Marine Air Heaters

### Air Top 2000 STC / Evo 40 / Evo 55

#### 9.6.1. Rotary switch

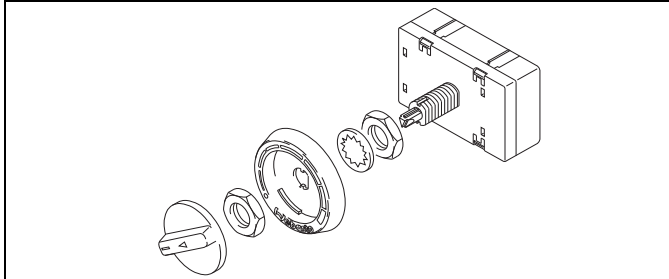

Fig. 41 Rotary switch control element

Connect the control element (ON/OFF and temperature preselection) with rotary potentiometer directly to the wiring harness.

See Fig. 14.

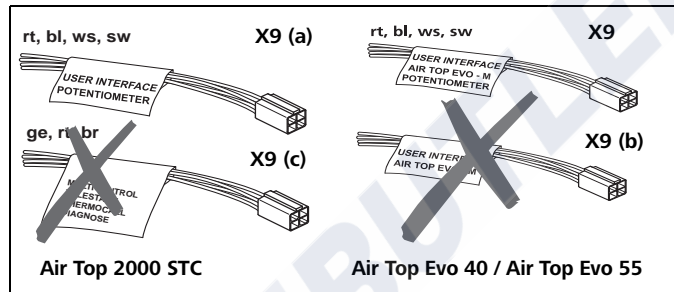

Fig. 42 Wiring of rotary switch

#### Air Top 2000 STC:

Attach X9(a) connector (cables rt, bl, ws, sw) to the control element.

Connector X9(c) is required to connect an optional control element or the Webasto Thermo Test PC diagnostics. See Fig. 42 and wiring diagram.

#### Air Top Evo 40 / Air Top Evo 55:

Plug X9a connector (rt, bl, ws, sw wires) with blue marking into the connector at the control element. When using a ventilation switch install an earthing cable leading to the switch. The resistor (R) must be installed for the Air Top Evo 40 / Air Top Evo 55.

See Fig. 42 and wiring diagram.

Connector X9b with the red marking is not required.

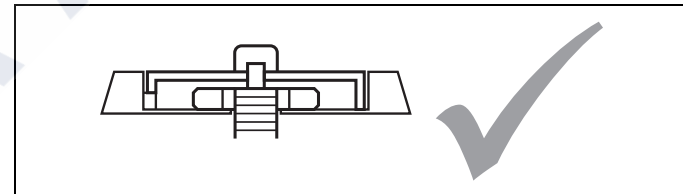

Fig. 43 Installing the control element

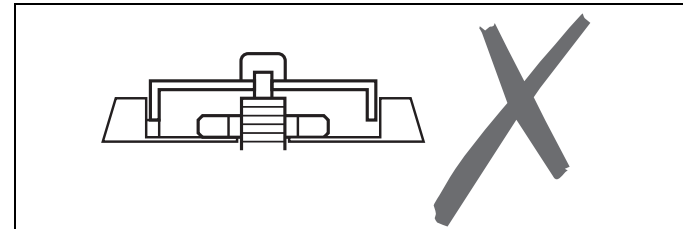

Fig. 44 Installing the control element (wrong)



## Electrical system

## Marine Air Heaters Air Top 2000 STC / Evo 40 / Evo 55

### 9.6.2. Air Top Evo MC04 control element (Marine)

The MC04 heater control element features additional operating modes such as ECO, PLUS and VENTILATION.

The MC04 can only be used in combination with Air Top Evo 40 / Air Top Evo 55 heaters.

- Make a 98 mm wide x 63 mm high cutout for the MC04.
  - Connect the control element to the two connectors on the heater wiring harness, paying attention to the labels on the wiring harness as well as the colour coding on the connectors.
- See Fig. 42 (connector X9a and X9b), as well as Fig. 45.
- Provisionally fit the control element in the cutout.
  - Lightly press the fastening screws into the holes and screw in. Carefully clip on the trim frame.

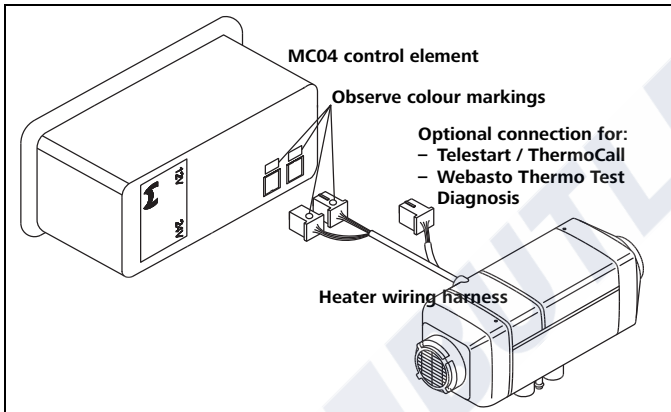

Fig. 45 connection Air Top Evo 40 / Air Top Evo 55 with control element MC04

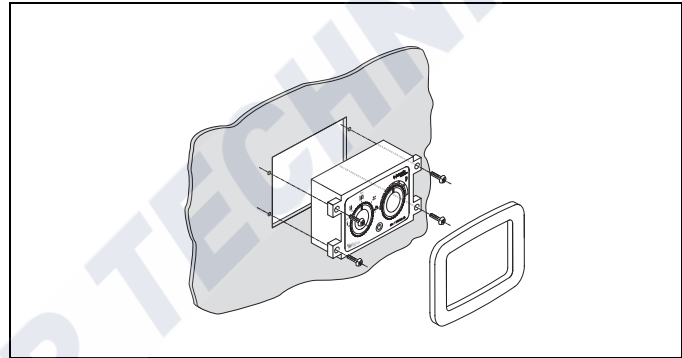

Fig. 46 Installation of control element MC04



## Marine Air Heaters

### Air Top 2000 STC / Evo 40 / Evo 55

#### 9.7. Optional control elements

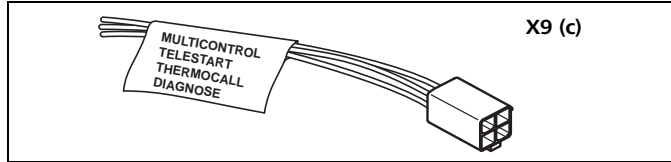

Fig. 47 MultiControl / UniControl / Telearstart / ThermoCall / diagnostics connector

##### - MultiControl / UniControl

The MultiControl / UniControl control element features additional operating modes such as VENTILATION and TIMER

- Connect X9(c) connector housing to the connector for the MultiControl or UniControl control element.
- Install the control element in accordance with the supplied Installation Instructions for the MultiControl or UniControl.

##### - Telearstart / ThermoCall

Connector X9c can be connected to the optional Telearstart remote control or the ThermoCall remote control

##### - Combination timer

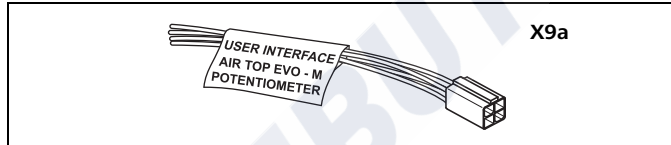

Fig. 48 Connector for Combi timer

Use the adapter wiring harness to install the Combi timer and connect it as shown in the wiring diagram (See "Wiring diagrams" from Page 89.). Use the fuses F2 and, if necessary, also F4 for separate display lighting.

#### 9.8. PC diagnosis, CO<sub>2</sub> calibration

- X9c connector (see Fig. 32 and Fig. 33) can also be used for Webasto Thermo Test PC diagnosis.
- Air Top 2000 STC: Additional connector X29 on the fuse holder for diagnostics.



##### NOTE:

The MultiControl (optional) must be switched off during the diagnostics.

- Use X15 connector for CO<sub>2</sub> calibration (only for Webasto service workshops). See Fig. 49.

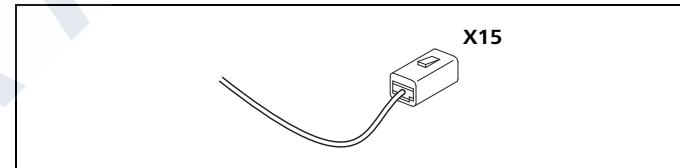

Fig. 49 Connector for CO<sub>2</sub> calibration or diagnostics, see wiring diagram

#### 9.9. Fuel pump

The wiring harness for the DP42 fuel pump is routed out of the combustion air intake connection piece. Pull out the stowed cable (do not push it back in) and connect it to the fuel pump; see wiring diagram. Use an extension cable if it is not long enough (accessory).





10 Wiring diagrams

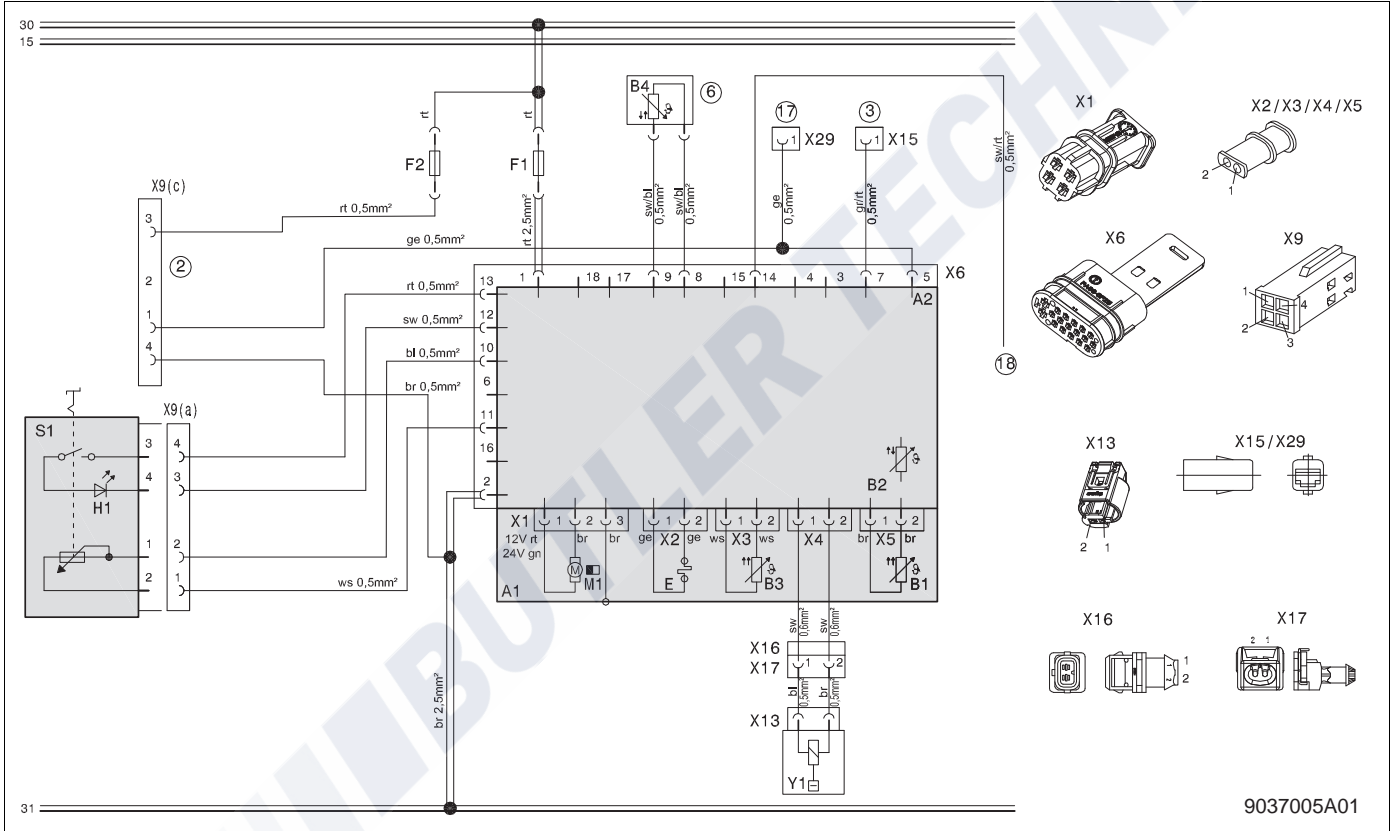

9037005A01

Fig. 50 Wiring diagram Air Top 2000 STC, with rotary switch control element, for legend, see Page 96



Marine Air Heaters  
Air Top 2000 STC / Evo 40 / Evo 55

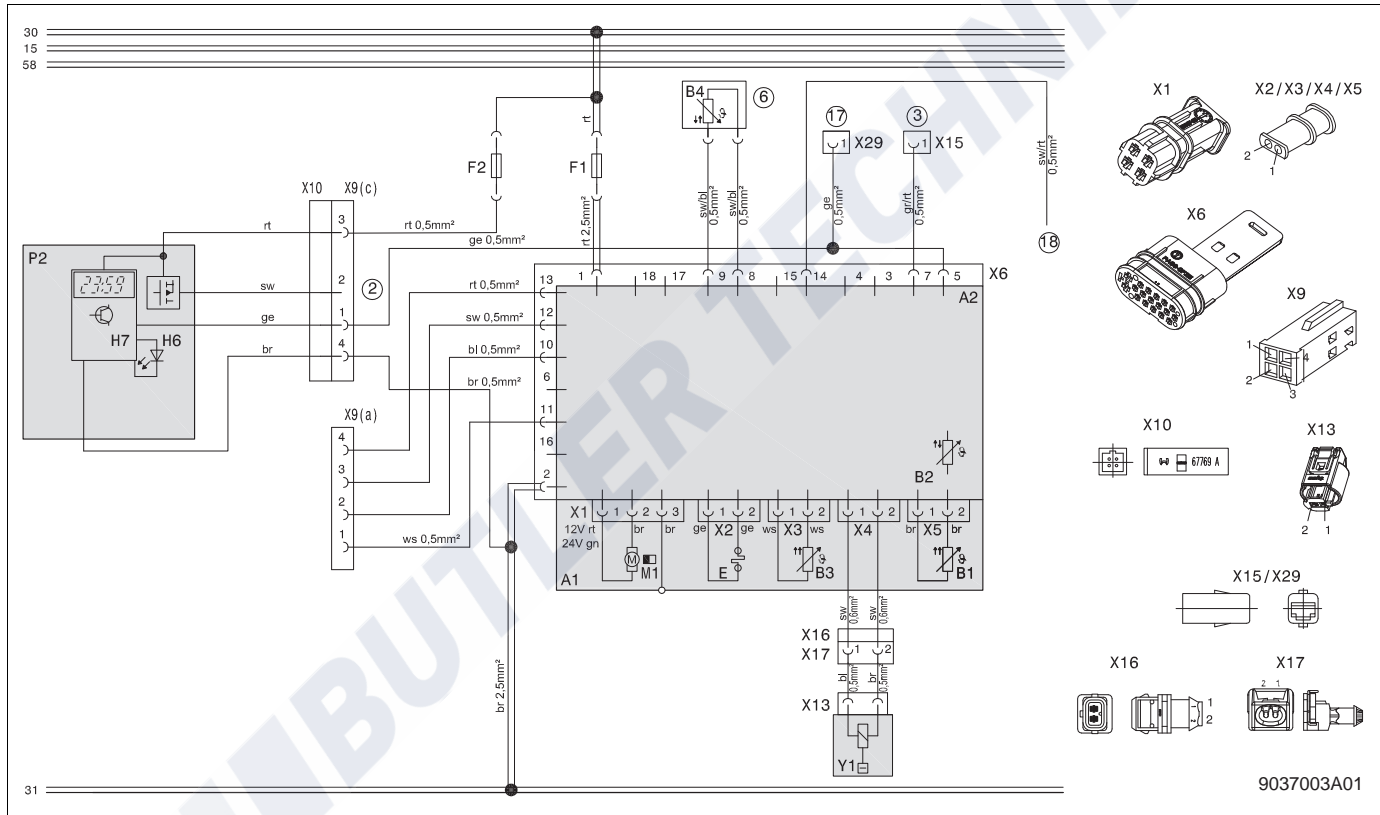

Fig. 51 System wiring diagram Air Top 2000 STC, with MultiControl, for legend see from Page 96



Electrical system

Marine Air Heaters  
Air Top 2000 STC / Evo 40 / Evo 55

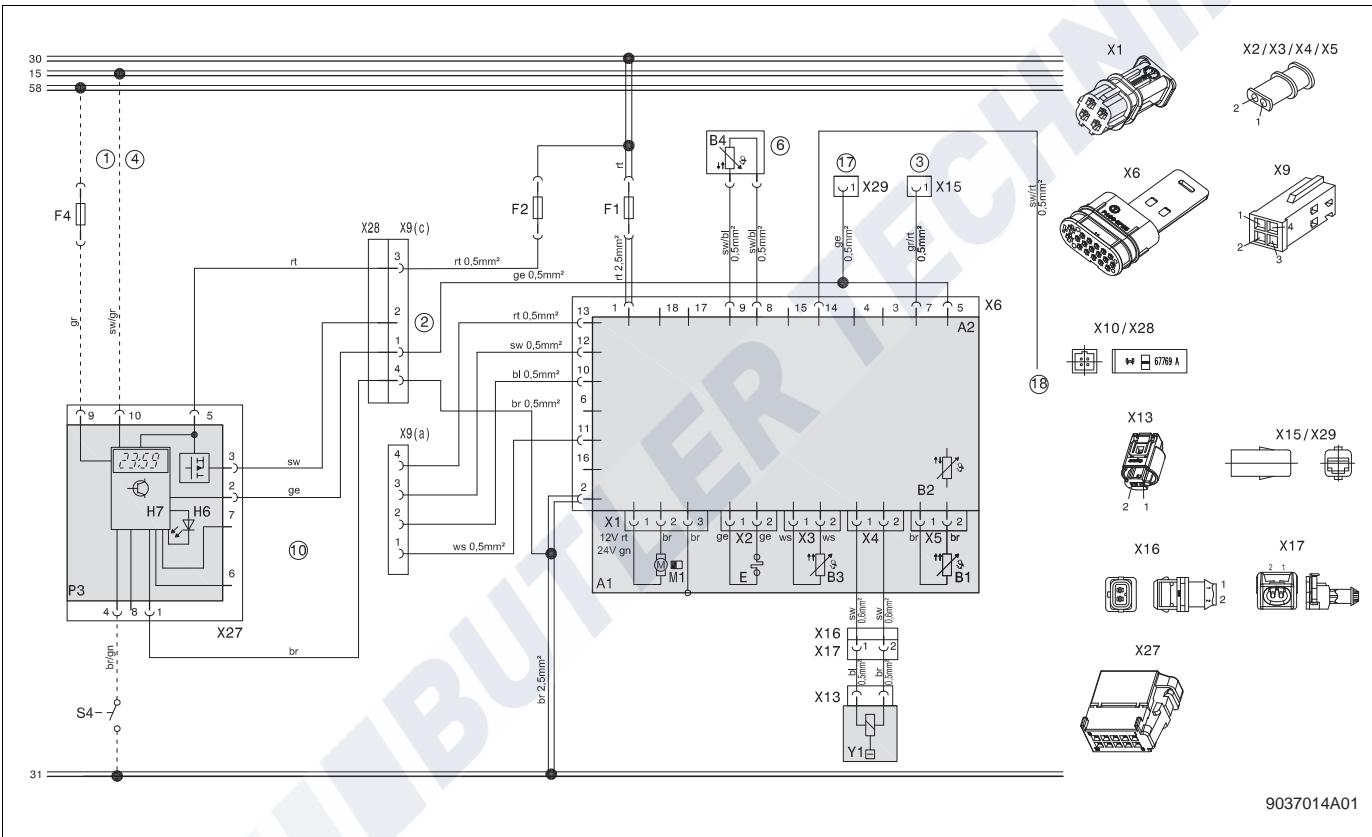

Fig. 52 System wiring diagram Air Top AT2000 STC UniControl, for legend see from Page 96

9037014A01

Marine Air Heaters

Air Top 2000 STC / Evo 40 / Evo 55

Electrical system

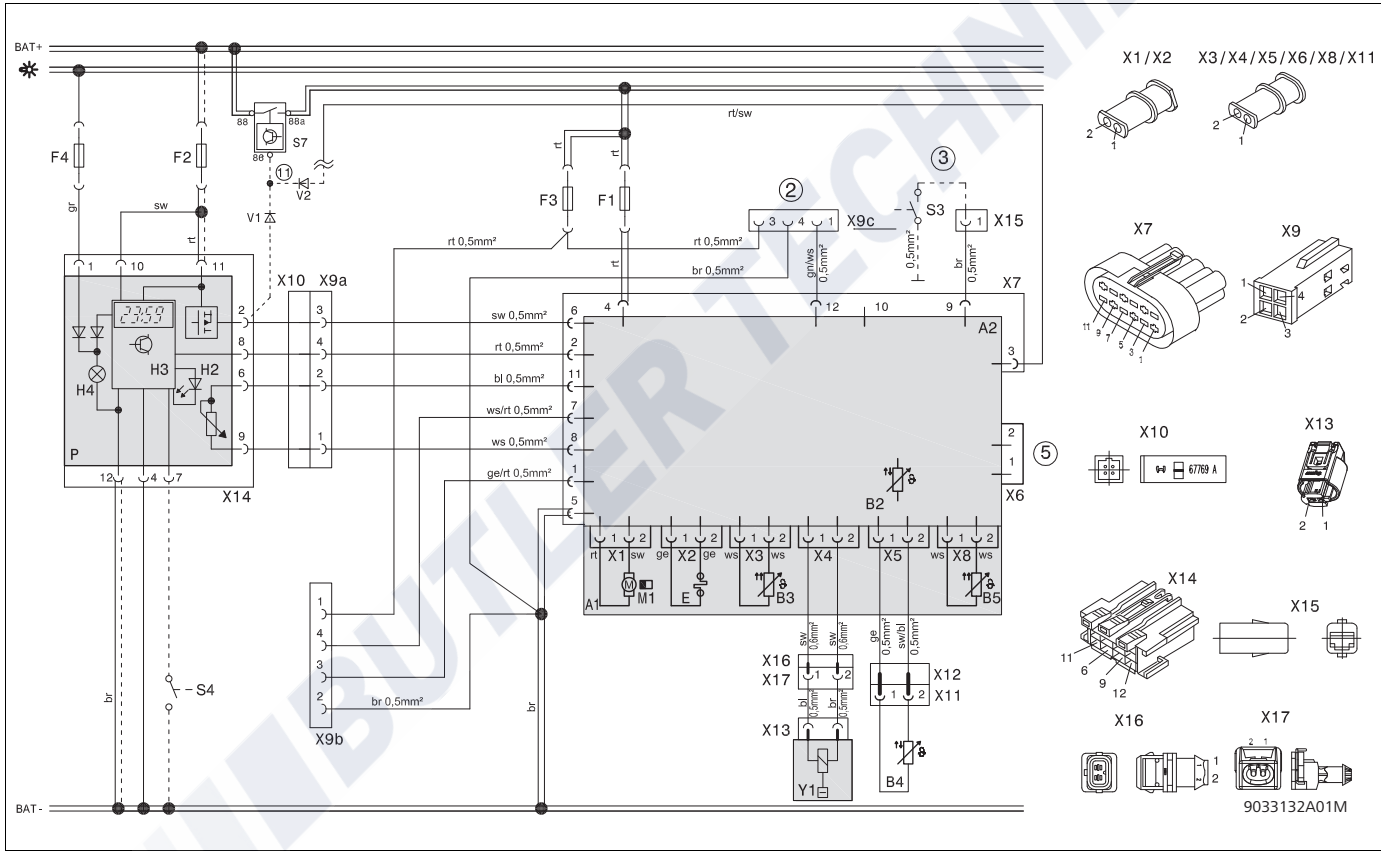
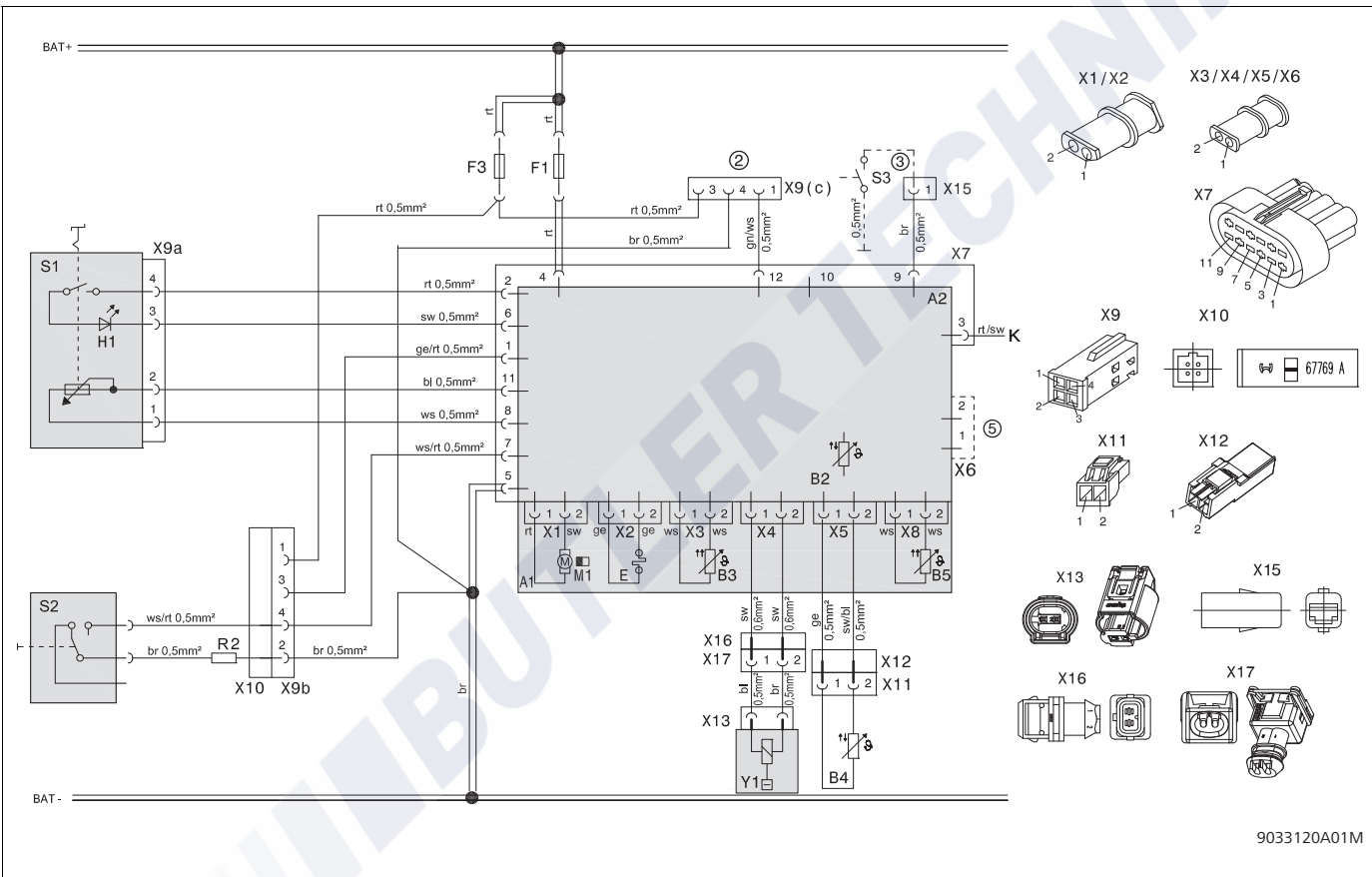

Fig. 53 Wiring diagram Air Top Evo 40 / Air Top Evo 55, with Combi timer, for legend see Page 96



Electrical system

Marine Air Heaters  
Air Top 2000 STC / Evo 40 / Evo 55



9033120A01M

Fig. 54 Wiring diagram for Air Top Evo 40 / Air Top Evo 55, with rotary switch and ventilation switch; for legend see Page 96



Marine Air Heaters  
Air Top 2000 STC / Evo 40 / Evo 55

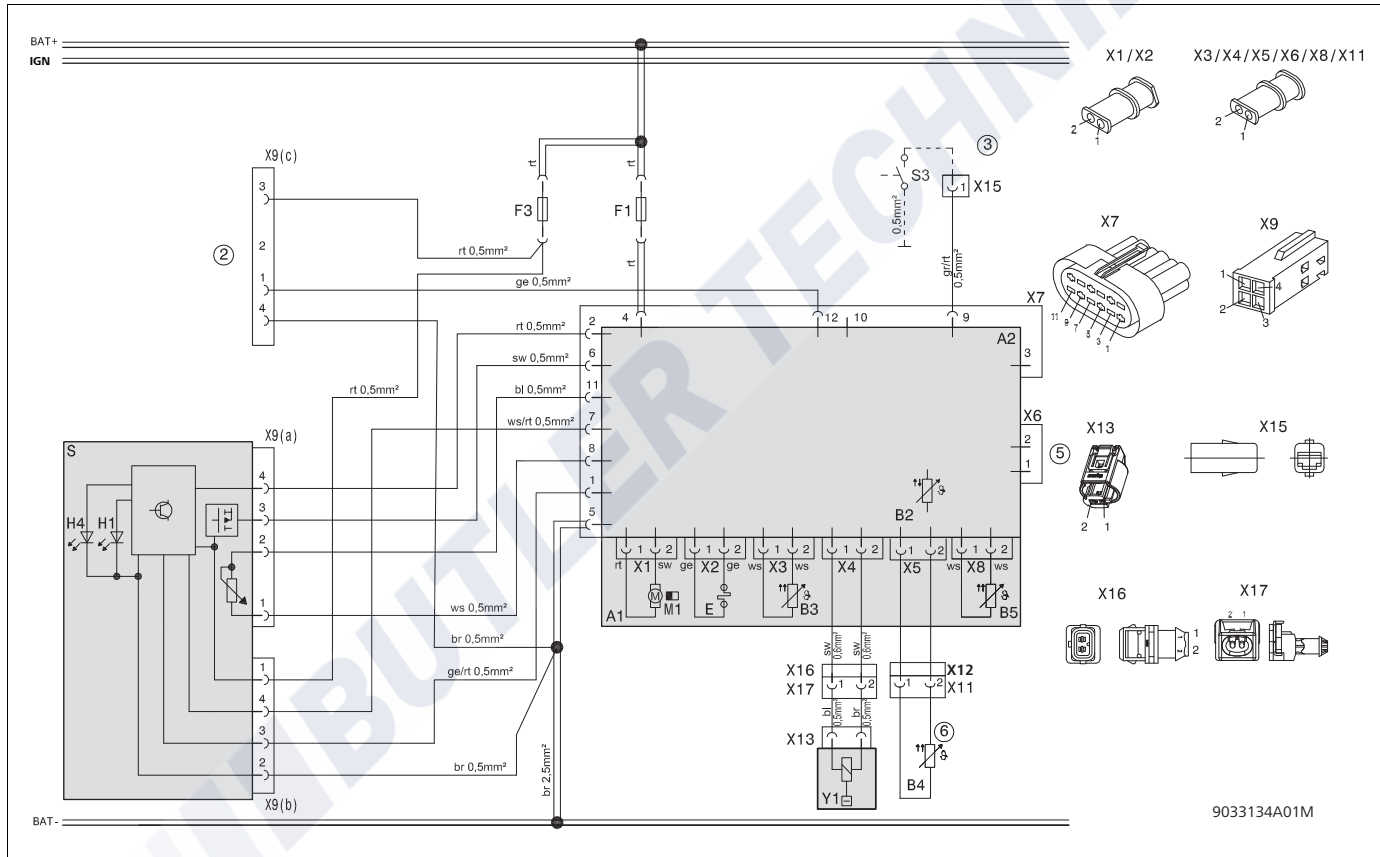
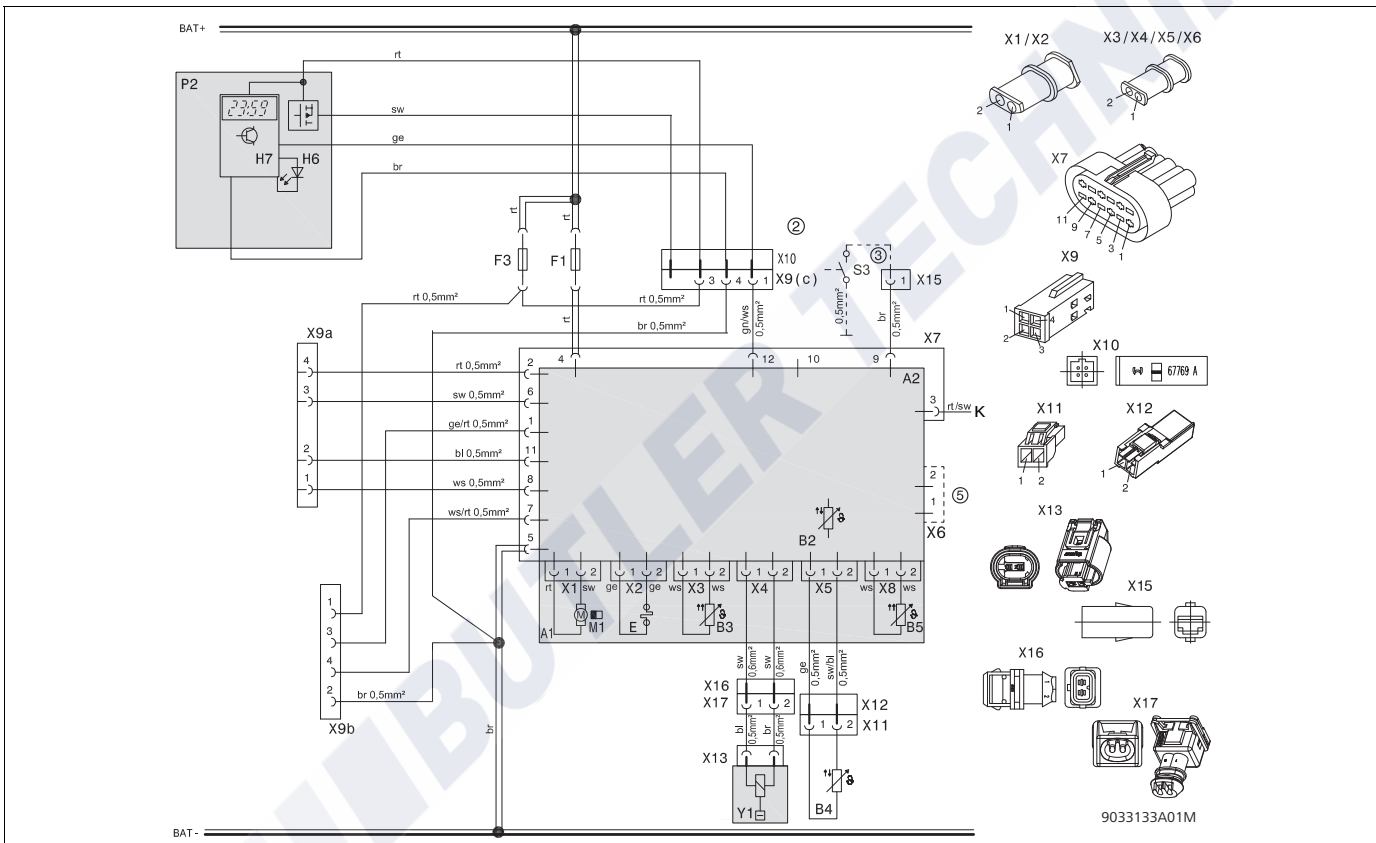

Fig. 55 Wiring diagram Air Top Evo 40 and Air Top Evo 55, with MultiControl (MC04) control element, for legend see Page 96



Electrical system

Marine Air Heaters  
Air Top 2000 STC / Evo 40 / Evo 55



9033133A01M

Fig. 56 Wiring diagram Air Top Evo 40 and Air Top Evo 55, with MultiControl control element, for legend see Page 96



## Marine Air Heaters

### Air Top 2000 STC / Evo 40 / Evo 55

#### 10.1. Legend to wiring diagrams

Item	Description	Remarks
A1	Heater	Air Top 2000 STC Air Top Evo 40 / Air Top Evo 55
A2	Control unit	Control unit 1574 (for Air Top 2000 STC) control unit 1580 (for Air Top Evo 40 / Air Top Evo 55)
B2	Temperature sensor	Inside
B3	Overheat sensor	Overheating protection
B4	Cabin temperature sensor	Outside
E	Glow plug / flame monitor	for Air Top Evo 40 / Air Top Evo 55 glow plug only
F1	Fuse 24 V 15A / 12V 20A	Blade fuse DIN 72581-3
F2	Fuse 1A	Blade fuse DIN 72581-3 (with Air Top 2000 STC) not included in wiring harness (with Air Top Evo 40 / Air Top Evo 55)
F3	Fuse 1A	not included in wiring harness (with Air Top 2000 STC) Blade fuse DIN 72581-3 (with Air Top Evo 40 / Air Top Evo 55)
F4	Fuse 1A	not included in wiring harness
H1	LED green (in Item S1)	ON indicator, fault code indicator
H2	LED red (in Item P)	Lighting: Quick heating button, ON indicator
H3	Heating symbol on display (in Item P)	ON indicator, ready indicator
H4	Bulb/LED (in Item P)	Display and button lighting
H6	LED (green, blue, white, red)	Operation indicator, Ready indicator, ON indicator, fault list
H7	Symbol on display	-
M1	Motor	Combustion air and heating air blower
P	Combination timer	Combination digital timer and temperature setpoint sensor
P2	MultiControl	(WBus)
P3	UniControl	-

Item	Description	Remarks
R2	Resistor	490 Ohm
R3	Resistor	100 + 910 Ohm
S	Multi Control (MC04) control element	ON switch, selector switch for additional functions and temperature selector
S1	Rotary switch control element	ON/OFF switch and temperature setpoint sensor
S2	Switch	Ventilation
S3	Switch	CO <sub>2</sub> setting
S4	Pushbutton	external Quick Heating button (optional)
S6	Switch, 1 or 2-pin	Disconnecter
S7	Battery disconnecter	electronically controlled disconnecter max. 500 mA
V1/ V2	Blocking diode	min. 500 mA (not included in wiring harness)
X1- X29	Plug connection	-
Y1	Fuel pump	DP42





## Electrical system

## Marine Air Heaters *Air Top 2000 STC / Evo 40 / Evo 55*

### 10.1.1. Legend for comments

No.	Remarks
①	With positive on connection 10: continuous heating mode is possible in connection with quick heating function provided the ignition is switched on.
②	MultiControl connection, Telestart (12 V only), ThermoCall or diagnostics via W-bus.
③	CO2 setting (see workshop manual).
④	With connection: continuous heating mode is possible with ignition switched off. Must not be connected to the battery plus terminal in this case!
⑤	Tie back.
⑥	External room temperature sensor.
⑦	WBus / diagnostics.
⑩	Adapter for wiring harness.
⑰	Diagnostics connection via WBus.
⑱	Output, battery disconnecter afterrunning signal.

### 10.1.2. Air Top 2000 STC: Pin assignment plug connection X6, 18-pin

Pin No.	Remarks
1	Power supply + (terminal 30)
2	Power supply - (terminal 31)
3	Not used
4	Not used
5	WBus (Webasto Thermo Test Diagnostics connection)
6	Not used
7	CO2 setting
8	external temperature sensor +
9	external temperature sensor -
10	Setpoint sensor +
11	Setpoint sensor -
12	Input, switch-on signal (ON/OFF)
13	Power supply, control element / error code output
14	Output, battery disconnecter afterrunning signal
15	Not used
16	Not used
17	Not used
18	Not used

## Marine Air Heaters

### Air Top 2000 STC / Evo 40 / Evo 55

## Electrical system



#### 10.1.3. Air Top Evo 40 / Air Top Evo 55: Pin assignment plug connection X7, 12-pin

Pin No.	Remarks
1	Output, battery disconnecter afterrunning signal / output, operating indicator
2	Power supply, control element / error code output
3	Output, battery disconnecter afterrunning signal / output, operating indicator
4	Power supply + (terminal 30)
5	Power supply – (terminal 31)
6	Input switch-on signal (ON/OFF)
7	Multifunction (ventilation, boost, ECO) with MC04 control element
8	Setpoint sensor -
9	CO2 setting
10	Not used
11	Setpoint sensor +
12	WBus

#### 10.1.4. Cable cross-sections

Cable	< 7.5 m	7.5 - 15 m
	0.75 mm <sup>2</sup>	1.0 mm <sup>2</sup>
	1.0 mm <sup>2</sup>	1.5 mm <sup>2</sup>
	1.5 mm <sup>2</sup>	2.5 mm <sup>2</sup>
	2.5 mm <sup>2</sup>	4.0 mm <sup>2</sup>
	4.0 mm <sup>2</sup>	6.0 mm <sup>2</sup>



#### NOTE:

Wires/components shown with dashed lines are optional and not included in the scope of delivery / in the wiring harness.

#### 10.1.5. Cable colours

Abbreviation	Colour
bl	blue
br	brown
ge	yellow
gn	green
gr	grey
or	orange
rt	red
sw	black
vi	violet
ws	white

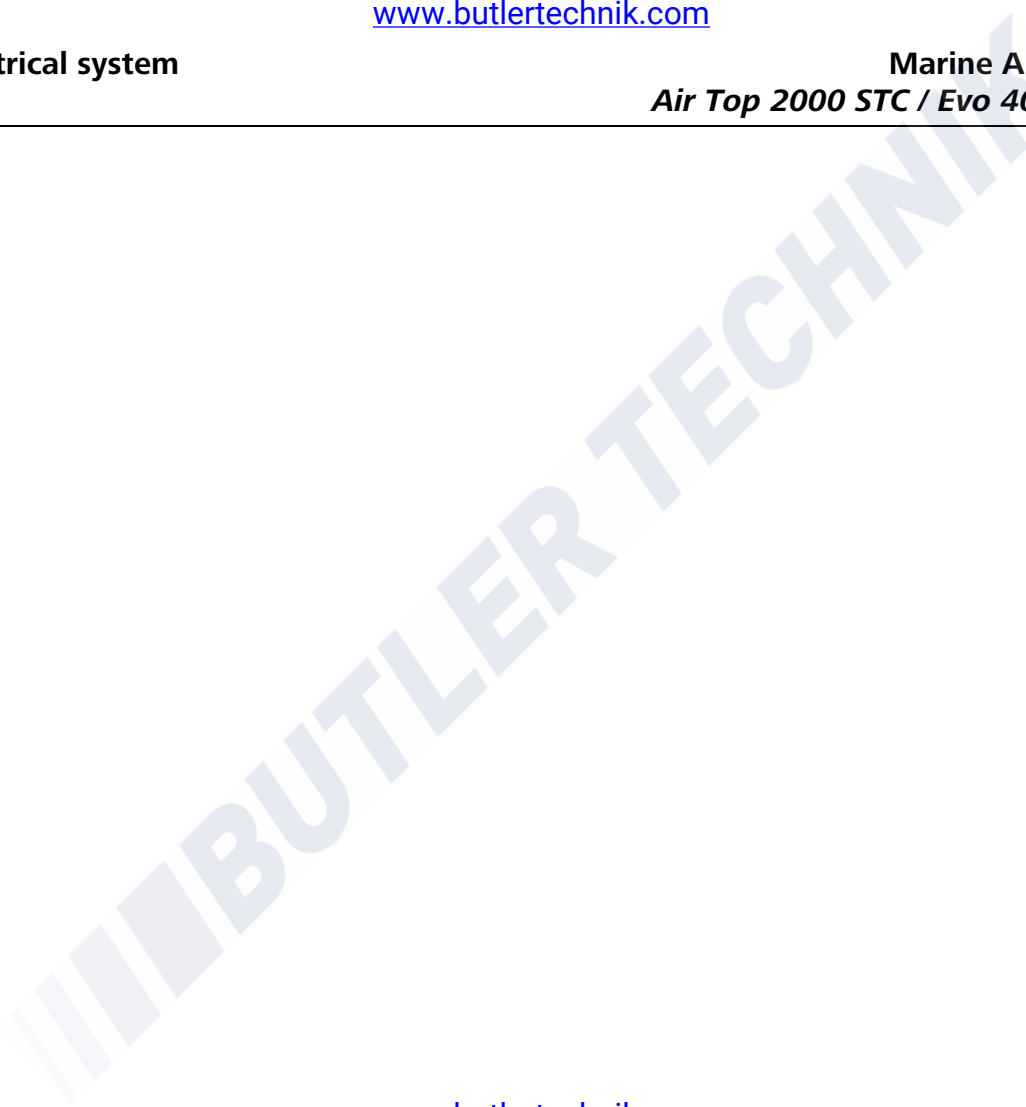

Bei mehrsprachiger Ausführung ist Deutsch verbindlich.

Die Telefonnummer des jeweiligen Landes entnehmen Sie bitte dem Webasto Servicestellenfaltblatt oder der Webseite Ihrer jeweiligen Webasto Landesvertretung.

In multilingual versions the German language is binding.

The telephone number of each country can be found in the Webasto service center leaflet or the website of the respective Webasto representative of your country.

Bij een meertalige versie is de Duitse versie bindend.

Het telefoonnummer van het betreffende land kunt u vinden op het Webasto Servicepuntenoverzicht of de website van de Webastovestiging in uw land.

Webasto Thermo & Comfort SE  
Postfach 1410  
82199 Gilching  
Germany

Company address:  
Friedrichshafener Str. 9  
82205 Gilching  
Germany

Internet: [www.webasto.com](http://www.webasto.com)

Technical Extranet: <https://dealers.webasto.com>

Nur innerhalb von Deutschland  
Tel.: 0395 5592 444  
E-mail: [technikcenter@webasto.com](mailto:technikcenter@webasto.com)