

# AIRTRONIC D5 L

**Technical description, installation,  
operation and maintenance instructions.**



Heater

Airtronic D5, 12 volt  
Airtronic D5, 24 volt

Order number

25 2361 05 00 00  
25 2362 05 00 00

**Air heater for diesel and petrol  
operating independently of the engine.**



**Eberspächer**  
A world of comfort

# 1 Introduction

## Contents

Chapter	Title	Contents	Page
1	<b>Introduction</b>	<ul style="list-style-type: none"> <li>• Contents..... 2</li> <li>• Concept of this manual..... 3</li> <li>• Special text structure, presentation and picture symbols..... 4</li> <li>• Important information before starting work..... 4</li> <li>• Statutory regulations..... 5, 6</li> <li>• Safety instructions for installation and operation..... 7</li> <li>• Accident prevention..... 7</li> </ul>	
2	<b>Product information</b>	<ul style="list-style-type: none"> <li>• Scope of supply..... 8, 9</li> <li>• Technical data..... 10</li> <li>• Main dimensions..... 11</li> </ul>	
3	<b>Installation</b>	<ul style="list-style-type: none"> <li>• Installation and mounting position..... 12</li> <li>• Installing the 24 volt heater in a vehicle for the transport of dangerous goods according to ADR..... 12</li> <li>• Installation location ..... 13</li> <li>• Possible mounting positions ..... 14</li> <li>• Installation and fixing..... 15</li> <li>• Nameplate..... 16</li> <li>• Hot air system ..... 17</li> <li>• Installation of pipe connection sockets and air outlets..... 18</li> <li>• Exhaust system ..... 19</li> <li>• Combustion air system..... 20</li> <li>• Fuel supply ..... 21 – 25</li> </ul>	
4	<b>Operation and function</b>	<ul style="list-style-type: none"> <li>• Operation instructions / important information for operation..... 26</li> <li>• Initial commissioning..... 26</li> <li>• Description of functions ..... 27</li> <li>• Control and safety devices / EMERGENCY OFF ..... 28</li> </ul>	
5	<b>Electrical system</b>	<ul style="list-style-type: none"> <li>• Heater wiring ..... 29</li> <li>• Parts list for the circuit diagrams / circuit diagrams ..... 29 – 37</li> </ul>	
6	<b>Faults Maintenance Service</b>	<ul style="list-style-type: none"> <li>• If any faults occur, please check the following items ..... 38</li> <li>• Troubleshooting ..... 38</li> <li>• Maintenance instructions ..... 38</li> <li>• Service ..... 38</li> </ul>	
7	<b>Environment</b>	<ul style="list-style-type: none"> <li>• Certification ..... 39</li> <li>• Disposal ..... 39</li> <li>• EU Declaration of Conformity..... 39</li> </ul>	
8	<b>List</b>	<ul style="list-style-type: none"> <li>• List of abbreviations..... 40</li> </ul>	



# 1 Introduction

## Concept of this manual

This manual aims to support the service company installing the heater and to provide the user with all important information about the heater. The manual has been divided into 8 chapters to make it easier to find the corresponding information quickly.

### 1 Introduction

This section contains important introductory information about installing the heater and about the structure of the manual.

### 2 Product information

Here you will find information about the scope of supply, the technical data and the dimensions of the heater.

### 3 Installation

Here you will find important information and instructions referring to installation of the heater.

### 4 Operation and function

Here you will find information about the operation and function of the heater.

### 5 Electrical system

Here you will find information about the electronic system and electronic components of the heater.

### 6 Troubleshooting / maintenance / service

Here you will find information on possible faults, maintenance and technical support.

### 7 Environment

Here you will find information about certification and disposal of the heater together with the EU Declaration of Conformity.

### 8 List

Here you will find the list of abbreviations.

# 1 Introduction

## Special text structure, presentation and picture symbols

This manual uses special text structures and picture symbols to emphasise different contents. Please refer to the examples below for the corresponding meanings and associated actions.

### Special structure and presentations

A dot (•) indicates a list which is started by a heading. If an indented dash (–) follows a dot, this list is subordinate to the dot.

### Picture symbols



#### Regulation!

This picture symbol with the remark "Regulation" refers to a statutory regulation. Failure to comply with this regulation results in expiry of the type permit for the heater and preclusion of any guarantee and liability claims on Eberspächer Climate Control Systems GmbH & Co. KG and its associated companies.



#### Danger!

This picture symbol with the remark "Danger!" refers to the risk of a fatal danger to life and limb. Under certain circumstances, failure to comply with these instructions can result in severe or life-threatening injuries.



#### Caution!

This picture symbol with the remark "Caution!" refers to a dangerous situation for a person and / or the product. Failure to comply with these instructions can result in injuries to people and / or damage to machinery.

#### Please note!

These remarks contain application recommendations and useful tips for installation of the heater.

## Important information before starting work

### Range of application of the heater

The air heater operating independently of an engine is intended for installation in the following vehicles, depending on its heating output:

- Vehicles of all kinds (max 9 seats)
- Construction machinery
- Agricultural machinery
- Boats, ships and yachts (only diesel heaters)
- Camper vans

#### Please note!

- The heaters (only diesel heaters, 24 volt) can be installed in vehicles used for the transport of dangerous goods as per ADR.
- The current controller is to be replaced by a special controller when the heater is to be used to heat the freight compartment / cargo (order no. see product overview).

### Purpose of the heater

- Pre-heating, de-misting windows
- Heating and keeping the following warm:
  - Driver and working cabs, Ship's cabins
  - Freight compartments
  - Passenger and crew compartments
  - Camper vans

On account of its functional purpose, the heater is **not** permitted for the following applications:

- Long-term continuous operation, e.g. for preheating and heating of:
  - Residential rooms
  - Garages
  - Work huts, weekend homes and hunting huts
  - Houseboats, etc.
- Heating or drying:
  - Living creatures (people or animals) by blowing hot air directly at the subject
  - Objects
  - Blowing hot air into containers



#### Caution!

### Safety instructions for application and proper purpose

- The heater must only be used and operated for the range of application stated by the manufacturer in compliance with the "Operating instructions" included with every heater.



# 1 Introduction

## Statutory regulations

The Federal Motor Transport Authority has issued an approval for a component according to ECE R122 and ECE-R10 for the heater for installation in motor vehicles, with the following official type-approval markings noted on the heater's nameplate.

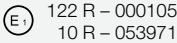
Heater type:	ECE type approval mark:
Airtronic L	 122 R - 000105 10 R - 053971

### Regulations!

**Excerpt from ECE regulation No. 122 of the European Parliament and the Council**

#### General regulations

##### • Operating state display

- A clearly visible operating display in the user's field of vision must indicate when the heater is switched on and off.

#### Regulations concerning installation in the vehicle

##### • Scope

- Subject to differing stipulations in the following section, combustion heaters must be installed according to the regulations 5.3 of ECE-R122.
- It is assumed that Class O vehicles with heaters for liquid fuel conform to the regulations 5.3 of ECE-R122.

##### • Arrangement of the heater

- Parts of the structure and other components near the heater must be protected from excessive heat exposure and possible fuel or oil contamination.
- The heater must not pose a fire hazard even when it overheats. This requirement is deemed to be fulfilled if adequate clearance is ensured for all parts during installation, sufficient ventilation is provided and fireproof materials or heat shields are used.
- The heater must not be mounted in the passenger compartment of vehicles in class M<sub>2</sub> and M<sub>3</sub>. However, a heater in a hermetically sealed enclosure which also complies with the aforementioned conditions may be used.
- The factory nameplate or duplicate must be affixed so that it can still be easily read when the heater is installed in the vehicle.

- All appropriate precautions must be taken when arranging the heater to minimise the risk of injuries to persons or damage to other property.

##### • Fuel supply

- The fuel intake connection must not be located in the passenger compartment and must be sealed with a properly closing lid to prevent any fuel leaks.
- In heaters for liquid fuel where the heater fuel is separate from the vehicle fuel, the type of fuel and intake connection must be clearly identified.
- A warning sign is to be fixed to the intake connection indicating that the heater must be switched off before refuelling.

##### • Exhaust system

- The exhaust outlet must be arranged so as to prevent any penetration of exhaust fumes into the vehicle interior through the ventilation system, warm air intakes or open windows.

##### • Combustion air intake

- The air for the heater's combustion chamber must not be sucked in from the vehicle's passenger compartment.
- The air intake must be arranged or protected in such a way that it cannot be blocked by other objects.

##### • Hot air intake

- The heater's air supply must consist of fresh air or circulated air and must be sucked in from a clean area, which cannot be contaminated by exhaust fumes from the engine, the combustion heater or any other source in the vehicle.

- The intake pipe must be protected by a grid or other suitable means.

##### • Hot air outlet

- The hot air pipes within the vehicle must be arranged or protected in such a way that there is no risk of injury or damage if they are touched.

- The air outlet must be arranged or protected in such a way that it cannot be blocked by any objects.

##### • Automatic control of the heating system

- If the engine fails, the heating system must be automatically switched off and the fuel supply stopped within 5 seconds. The heater may remain in operation if a manual device has already been activated.

# 1 Introduction

## § Regulations

### Additional regulations for certain vehicles named in Directive 94 / 55 / EC of the ADR Agreement

#### Scope

This appendix applies to vehicles for which the special provisions of Directive 94 / 55 / EC apply to combustion heaters and their installation.

#### Definition of terms used

The vehicle designations "EX / II", "EX / III", "AT", "FL" and "OX" according to Chapter 9.1 of the ADR Agreement Directive 94 / 55 / EC are used for the purposes of this annex.

#### Technical regulations

##### General provisions (EX / II, EX / III, AT, FL and OX vehicles)

##### Avoid heating and ignition

The combustion heaters and their exhaust gas routing shall be designed, located, protected or covered so as to prevent any unacceptable risk of heating or ignition of the load. This requirement shall be considered as fulfilled if the fuel tank and the exhaust system of the appliance conform to provisions in 3.1.1.1 and 3.1.1.2. Compliance with these regulations shall be checked in the complete vehicle.

##### Fuel tanks

Fuel tanks for supplying the heater shall conform to the following regulations:

- In the event of any leakage, the fuel shall drain to the ground without coming into contact with hot parts of the vehicle or the load;
- fuel tanks containing petrol shall be equipped with an effective flame trap at the filler opening or with a closure enabling the opening to be kept hermetically sealed.

##### Exhaust system and exhaust pipe layout

The exhaust system as well as the exhaust pipes shall laid out or protected to avoid any danger to the load through heating or ignition. Parts of the exhaust system situated directly below the fuel tank (diesel) shall have a clearance of at least 100 mm or be protected by a thermal shield.

##### Switching on the combustion heater

The combustion heater may only be switched on manually. Automatic switching on via a programmable switch is not permitted.

##### EX / II and EX / III vehicles

Combustion heaters for gaseous fuels are not permitted.

#### FL vehicles

Combustion heaters must be able to be taken out of service/disabled at least by the methods described in the following:

- a) Switching off manually in the driver's cabin
- b) Switching off the vehicle's engine; in this case the heater may be manually switched back on by the vehicle driver;
- c) Starting up of a feed pump installed in the vehicle for the dangerous goods carried.

#### Combustion heater after-run

After-running of the switched off combustion heater is permitted. In the cases named in the „FL vehicles“ paragraph under letters b) and c) the supply of combustion air must be interrupted by suitable means after a maximum after-run period of 40 seconds. Only combustion heaters whose heat exchangers are verifiably not damaged by the reduced after-run period of 40 seconds beyond their usual use period may be used.

#### Please note!

- Compliance with the statutory regulations, the additional regulations and safety instructions is prerequisite for guarantee and liability claims. Failure to comply with the statutory regulations and safety instructions and incorrect repairs even when using original spare parts make the guarantee null and void and preclude any liability for Eberspächer Climate Control Systems GmbH & Co. KG.
- Subsequent installation of this heater must comply with these installation instructions.
- The statutory regulations are binding and must also be observed in countries which do not have any special regulations.
- When the heater is to be installed in vehicles not subject to the German Ordinance for the Registration of Motor Vehicles (StVZO), for example ships, the specially valid regulations and installation instructions for these special applications must be observed.
- Installation of the heater in special vehicles must comply with the regulations applying to such vehicles.
- Other installation requirements are contained in the corresponding sections of this manual.



# 1 Introduction

## Safety instructions for installation and operation



### Danger!

#### Risk of injury, fire and poisoning!

- The heater must only be started up if the intake and outflow hoods have been fitted.
- Disconnect the vehicle battery before commencing any kind of work.
- Before working on the heater, switch the heater off and let all hot parts cool down.
- The heater must not be operated in closed rooms, e. g. in the garage or in a multi-story car park.
- Adjustable hot air outlets must always be adjusted so that they cannot blow hot air directly at living creatures (people, animals) or object sensitive to temperature (loose and / or fastened).



### Caution!

#### Safety instructions for installation and operation!

- The year of initial commissioning must be marked on the nameplate.
- The heat exchanger of air heaters is a component subject to high thermal loads, which must be replaced 10 years after the initial commissioning of the heater. In addition, the installation date must be entered on the plate "original spare part" enclosed with the heat exchanger. Then affix the plate next to the nameplate on the heater.
- The heater must only be installed by a JE partner, authorised by the manufacturer, according to the instructions in this documentation and any special installation recommendations. The same applies to any necessary repairs or in case of guarantee claims.
- Only the control elements approved by Eberspächer Climate Control Systems GmbH & Co. KG must be used to operate the heater. Use of other control elements can cause malfunctions.
- Repairs by non-authorised third-parties or with not original spare parts are dangerous and therefore not allowed. They result in expiry of the type permit of the heater; consequently, when installed in motor vehicles they can cause expiry of the vehicle operating licence.
- The following measures are not allowed:
  - Changes to components relevant to the heater.
  - Use of third-party components not approved by Eberspächer.

- Departures from the statutory regulations, safety instructions and / or functional specifications given in these documents with regard to installation or operation. This applies in particular to the electrical wiring, fuel supply, combustion air system and exhaust system.
- Only original accessories and spare parts may be used for installation or repairs.
- When carrying out electric welding on the vehicle, the plus pole cable at the battery should be disconnected and placed at ground to protect the controller.
- Do not operate the heater anywhere where there are readily flammable materials (e.g. dry grass, leaves, paper, etc.) in the area of the exhaust system or where ignitable fumes and dust can form, e.g. near a
  - fuel depot
  - coal depot
  - wood depot
  - grain depots, etc.
- The heater must be switched off when refuelling.
- If the heater is fitted in a safety casing, etc., the heater's installation box must not be used as storage space and must be kept clear. In particular, fuel canisters, oil cans, spray cans, gas cartridges, fire extinguishers, cleaning rags, items of clothing, paper, etc. must not be stored or transported on or next to the heater.
- Defective fuses must only be replaced by fuses with the prescribed fuse value.
- If fuel escapes from the heater's fuel system (leak), arrange for immediate repair of the damage by a JE service partner.
- The after-running of the heater must not be prematurely interrupted e.g. by pressing the battery disconnect switch, except for an emergency stop.

#### Please note!

Following installation, attach the „Switch off heater before refuelling!“ sticker near the tank filler neck.

### Accident prevention

General accident prevention regulations and the corresponding workshop and operating safety instructions are to be observed.

## 2 Product information

### Scope of supply for Airtronic L – B5

Quantity / Designation	Order no.
1 Airtronic L – B5, 12 V	20 1859 05 00 00
To be ordered separately:	
1 Universal installation kit	25 2361 80 00 00
1 Control element*	–

### Scope of supply for Airtronic L – D5

Quantity / Designation	Order no.
1 Airtronic L – D5, 12 V	25 2361 05 00 00
1 Airtronic L – D5, 24 V	25 2362 05 00 00
To be ordered separately:	
1 Universal installation kit	25 2361 80 00 00
1 Control element*	–

\* Control elements see price list or product overview.

Parts list for the picture “Scope of supply“ on page 9

### Scope of supply for heater

#### No. in figure Designation

1	Heater
2	Dosing pump

### Scope of supply for universal installation kit

#### No. in figure Designation

3	Grid, Ø 90 mm
4	Outflow
5	Hose clip, Ø 90 mm – 110 mm (2x)
6	Flexible pipe, Ø 90 mm
7	Support (3x)
8	Pipe clip, Ø 50 mm
9	Intake silencer
10	Flexible exhaust pipe, Ø 24 mm
11	Cable tape 200 (2x 10 pcs)
12	Fuel pipe, 4 x 1.25, 7.5 m long
13	Fuse-switch
14	Plus cable, 1 <sup>2</sup> rt
15	Plus cable, 4 <sup>2</sup> rt
16	Wiring harness
17	Bracket dosing pump
18	Fuel pipe, 6 x 2, 1.5 m long
19	Hose connector 8 / 6 / 8
20	Hose connector 10 / 6 / 10

#### Please note!

- Parts without a figure no. are small parts and packed in a bag.
- If other parts are required for the installation, see product overview.





## 2 Product information

### Scope of supply

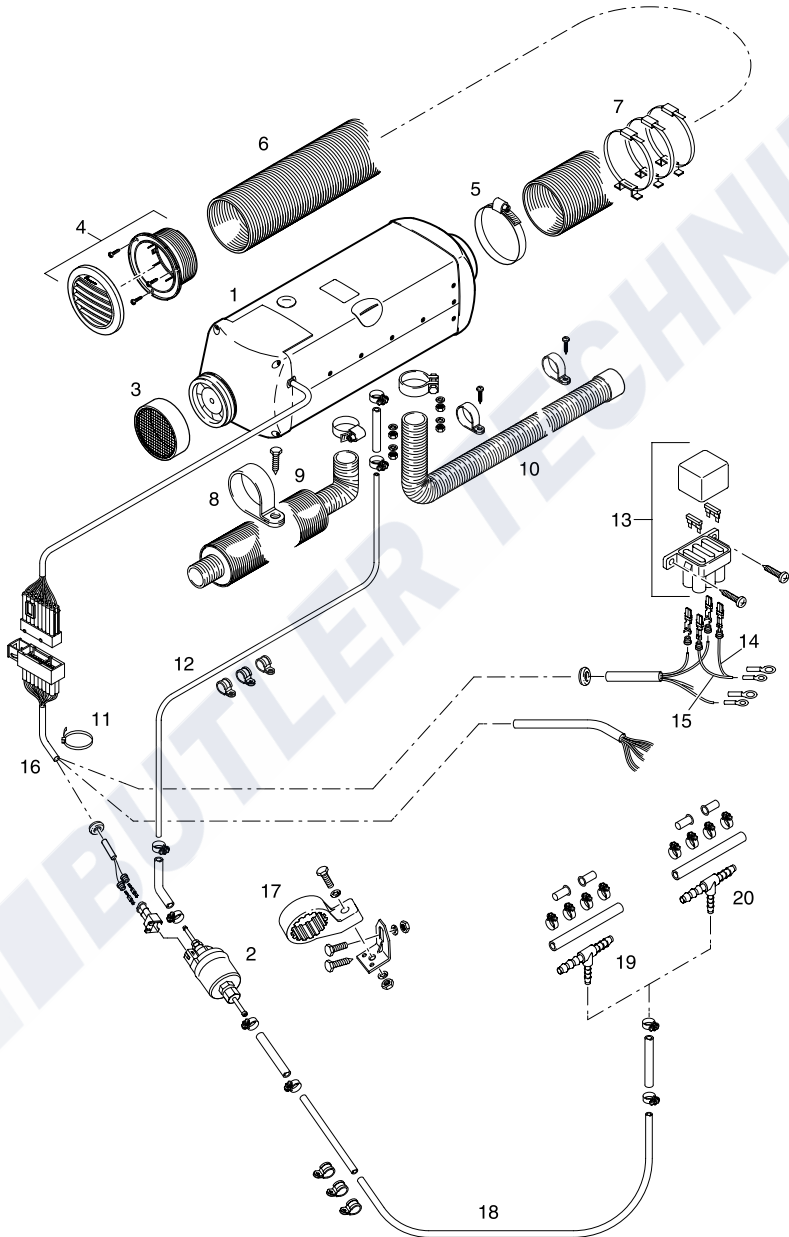

## 2 Product information

### Technical data

Heatertype	Airtronic L							
	Airtronic B5				Airtronic D5			
Heater	B5				D5			
Version	B5				D5			
Heating medium	Air				Air			
Control of the heat flow	Stage				Stage			
	Power	High	Medium	Low	Power	High	Medium	Low
Heat flow (watt)	5500	4800	2700	2000	5500	4800	2700	1600
Heater air flow rate without counterpressure (kg/h)	280	275	180	125	280	275	190	155
Heater code	10				10			
Fuel consumption (l/h)	0.75	0.65	0.37	0.27	0.66	0.58	0.34	0.20
Elec. power consumption (watt)	in operation				in operation			
	85	80	30	15	85	80	35	25
	while starting				while starting			
	< 250				< 250			
Rated voltage (volt)	12				12 / 24			
Operating range	Lower voltage limit: An undervoltage protector installed in the control box switches off the heater when the voltage limit is reached.							
	ca. 10.5 volt resp. ca. 21 volt Undervoltage protection response time: 20 seconds							
Operating range	Upper voltage limit: An overvoltage protector installed in the control box switches off the heater when the voltage limit is reached.							
	ca. 16 volt resp. ca. 32 volt Overvoltage protection response time: 20 seconds							
Fuel	Petrol – standard commercial quality (DIN EN 51600 / DIN EN 228)				Diesel fuel – standard commercial quality (DIN EN 590)			
	"Fuel quality" and "fuel at low temperatures" see operating instructions page 25.							
Permissible ambient temperature	Heater	Controller	Dosing pump		Heater	Controller	Dosing pump	
	Operation	-40 °C to +50 °C	-40 °C to +75 °C	-40 °C to +20 °C	-40 °C to +70 °C	-40 °C to +75 °C	-40 °C to +50 °C	
	Storage	-40 °C to +85 °C	-40 °C to +85 °C	-40 °C to +85 °C	-40 °C to +85 °C	-40 °C to +85 °C	-40 °C to +85 °C	
Maximum air intake temperature	+40 °C							
Interference suppression	Suppression class 5 to DIN 55025							
Weight	ca. 9.3 kg							
Ventilation mode	possible							



#### Caution!

#### Safety instructions for technical data!

Failure to comply with the technical data can result in malfunctions.

#### Please note!

Provided no limit values are given, the technical data listed is subject to the tolerances usually applicable to heaters of ±10% for nominal voltage, ambient temperature 20 °C and reference altitude Esslingen.



## 2 Product information

### Main dimensions

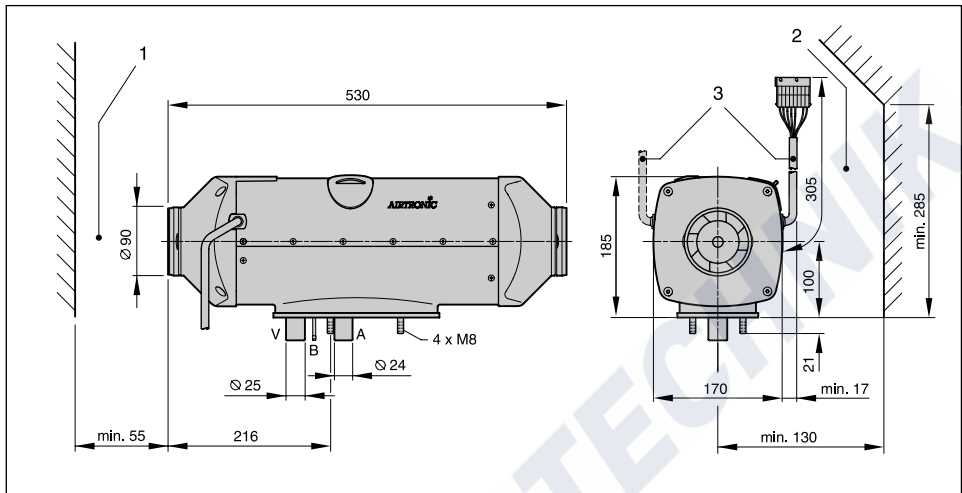

- 1 Minimum installation space (clearance) required for hot air intake and for dismantling the intake hood.
- 2 Minimum installation space (clearance) required for dismantling the glow plugs and controller.
- 3 Wiring harness connection, right or left-hand possible (see "Wiring harness connection, right or left-hand").

A = Exhaust  
 B = Fuel  
 V = Combustion air

### Cable harness connection, optionally right or left

If necessary, the cable harness can be changed over to the opposite side of the heater. The controller can be removed after the intake hood has been dismantled. Unclip the semi-circular cable harness cover on the controller and relay the cable harness. Then fit the semi-circular cable harness cover back onto the controller. Install the controller. Push the grommet of the cable harness and the dummy grommet in the corresponding holes of the upper sleeve casing. Refit the intake hood.

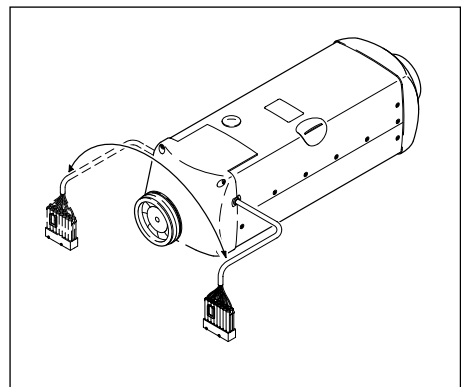

### 3 Installation

---

#### Installation and mounting position

The heater is suitable and approved for installation in vehicle interiors used by people.

The heater, together with its heater flange and the mounted flange seal, is fixed directly onto the floor of the vehicle or in a suitable position in the rear panel of the vehicle.

**Please note!**

- If installed inside the vehicle, detachable connections of exhaust gas, combustion air and fuel lines are **not** allowed.
- The flange seal must be mounted on the heater, in order to seal off the openings for the exhaust gas, combustion air and fuel lines.
- Installation in the driver's cab or passenger compartment of commercial buses with more than 9 seats (8 seats + driver's seat) is not allowed.
- The ADR regulations must also be complied with for installation of the heater in vehicles used to transport dangerous goods.  
For information on the ADR regulations, see page 6, 27 and in the information sheet with Print No. 25 2161 95 15 80.
- When installing the heater, ensure sufficient open space is allowed for intake of the heating air and for the dismantling of glow plugs and control box (see page 15 "main dimensions").
- Observe the regulations and safety instructions for this chapter, given on pages 4 – 7.



### 3 Installation

#### Installation location

##### Installation location in a delivery truck or van

In a delivery truck or van, the heater should preferably be installed in the vehicle interior or cargo area. If it is not possible to install the heater in the vehicle interior or cargo area, the heater can also be fitted under the vehicle floor.

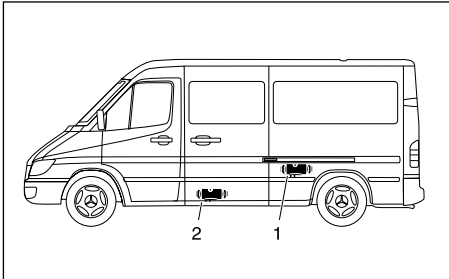

- 1 Heater in the vehicle interior or cargo area
- 2 Heater fitted under the vehicle floor

##### Installation location in a trailer

In a trailer, the heater is preferably installed in a box in the upper part of the end panel of the trailer. In this case, for recirculation mode, select hot air intake in the lower part of the trailer and hot air outflow in the lower area.

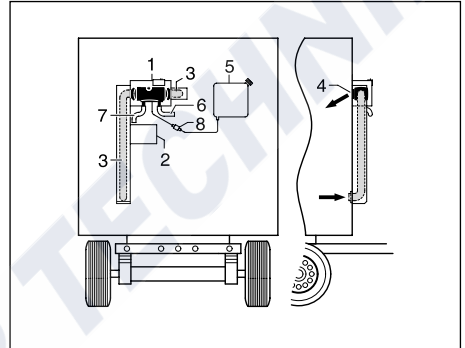

- 1 Heater
- 2 Battery
- 3 Flexible pipe for hot air
- 4 Outlet for hot air
- 5 Additional fuel tank
- 6 Exhaust pipe
- 7 Combustion air hose
- 8 Fuel dosing pump

#### Please note!

- The positions suggested in the installation instructions are examples. Other mounting positions are possible, as long as they correspond to the installation requirements stated in these instructions.
- Other installation information (e. g. for boats and ships) is available from the manufacturer on request.
- Observe the permissible mounting positions as well as the operating and storage temperatures.

### 3 Installation

#### Permitted mounting positions

The heater should preferably be installed in the standard position as shown in the drawing.

Depending on the installation conditions, the heater can be tilted by max.  $30^\circ$  (flow direction downwards!) or turned by max.  $90^\circ$  around its own longitudinal axis (exhaust connection horizontal, glow plug points upwards!), as shown in the drawing.

In heating mode, the standard or maximum installation positions shown can differ by up to  $+15^\circ$  in all directions, due to tilted vehicle or boat positions, without impairing the heater's function.

#### Normal horizontal position (exhaust connection facing downwards) with permissible swivel ranges

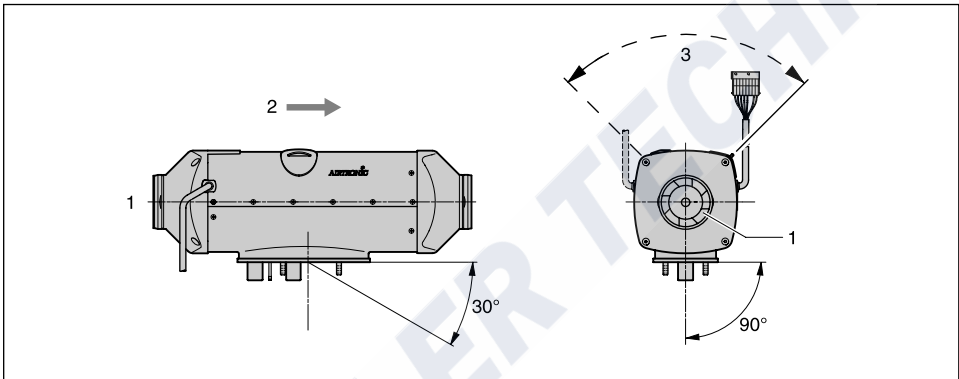

- 1 Hot air intake opening (fan wheel)
- 2 Direction of flow
- 3 Position of the glow plug



### 3 Installation

#### Installation and fixing

Make the through-holes for exhaust, combustion air and fuel as shown in the drilling hole pattern.

The support surface for the heater base must be flat. The  $\varnothing 10.5$  mm hole for the "dosing pump" cables is not included in the drilling hole pattern and must be drilled depending on the installation.

If the sheet metal of the support surface is thinner than 1.5 mm, an additional reinforcing plate will have to be fitted.

Order no: reinforcing plate 25 1729 89 00 03

#### Drilling hole pattern

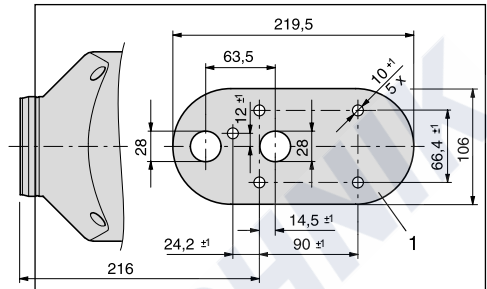

1 Contour of the bearing surface.

#### Fixing the heater to the vehicle floor

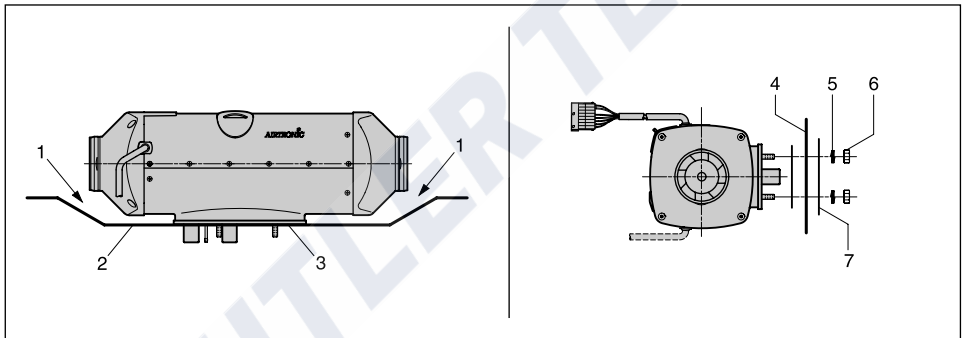

- 1 There must be sufficient clearance between the heater and the vehicle floor – in addition, check that the fan wheel runs freely.
- 2 The mounting surface must be flat and smooth.
- 3 The flange seal must be fitted.

#### Fixing the heater horizontally to the vehicle wall (panel)

- 4 The vehicle wall must be flat and smooth.
- 5 Spring washer
- 6 4 x M8 hexagonal nut (tightening torque  $11^{+1}$  Nm)
- 7 Reinforcing plate (if needed, Order no. 25 1729 89 00 03)

### 3 Installation

#### Nameplate

The nameplate is fixed onto the upper jacket shell. A 2nd nameplate (duplicate) is available as an additional part.

**Please note!**

Observe the regulations and safety instructions for this chapter given on page 5.

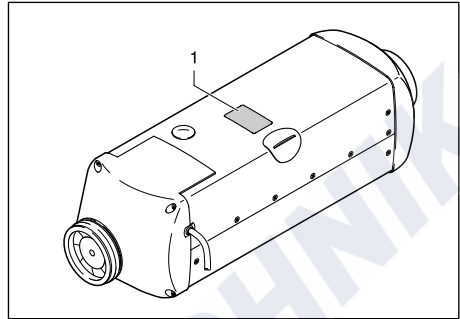

1 Original nameplate





### 3 Installation

#### Hot air system

The universal installation kit includes a 0.5 m long flexible pipe, an outlet, three supports with cable tapes and a safety grid for the hot air system. If further ducting parts are required for the installation, see product overview.



#### Danger!

##### Risk of burning and injuries!

- The hot air system hoses and the hot air outlet are to be laid and fastened in such a way that they do not pose a risk to people, animals or materials sensitive to temperature due to radiation / contact or direct blowing.

If necessary, a cover is to be fitted over the hot air ducting and / or the hot air outlet.

- The outflow hood must be fitted on the hot air outflow side.
- If no air hoses are fitted, a safety grid must be fitted to the hot air intake side and outflow side, to prevent injuries from the heater fan or burns from the heat exchanger.
- High temperatures occur in the hot air system while the heater is running and immediately afterwards.

This is why it is important to avoid working in the vicinity of the hot air system while the heater is running. In such cases, switch off the heater beforehand and wait until all parts have completely cooled down. If necessary, wear safety gloves.

#### Please note!

- Comply with the regulations and safety instructions for this chapter given on page 4 – 7.
- When connecting parts which conduct air, observe the heater code number given in the technical data (page 10).



#### Caution!

##### Safety instructions!

- The hot air intake openings must be positioned in such a way that, under normal circumstances, it is not possible for exhaust from the vehicle engine and heater to be sucked into the system, or for the hot air to be contaminated with dust, salt spray, etc.
- For circulating air mode, position the circulating air intake in such a way that the outflowing hot air cannot be directly sucked in again.
- In the event of overheating, it is possible for local hot air temperatures of up to max. 150 °C or surface temperatures of up to max. 90 °C to occur immediately before the safety lock-out.

Therefore only temperature-resistant hot air hoses approved by us must be used for the hot air system!

- When checking the functions, the mean discharge temperature measured approx. 30 cm from the outlet after the heater has been running for about 10 minutes should not exceed 110 °C (with an intake temperature of approx. 20 °C).
- If there is a risk of the driver and passengers touching the heater during normal vehicle operation, a touch guard must be fitted.

#### Hot air system (example)

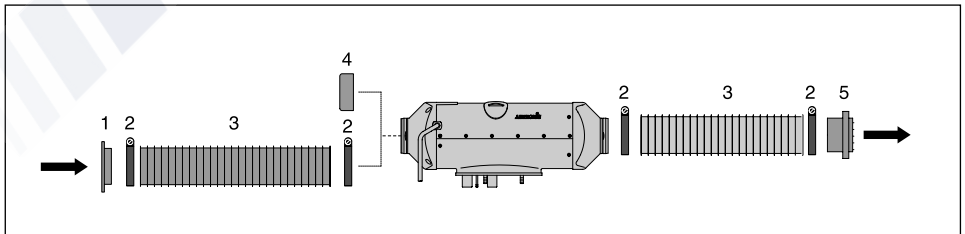

- 1 Connectors with safety grid
- 2 Hose clip
- 3 Flexible pipe

- 4 Safety grid
- 5 Outlet

### 3 Installation

#### Installation of pipe connection sockets and air outlets

##### Cutting out the opening for the connection sockets

Use a keyhole saw to cut out an opening for the connection socket at the planned place of installation (vehicle floor or wall).

Pipe connection socket  $\varnothing$  75 mm /  $\varnothing$  90 mm – keyhole saw  $\varnothing$  92 mm.

##### Fixing the pipe connection socket

Insert the pipe connection socket in the drillhole. Mark and drill three fixing holes  $\varnothing$  2 mm. Use 3 pan-head tapping screws (3.9 x 13) to EN ISO 7049 to fix the connection sockets. Torque max.  $1^{+0.5}$  Nm.

**Please note!**

Use pan-head screws only to install the connection socket, do not use countersunk head screws.

##### Fix air outlet onto the pipe connection socket

Clip the corresponding air outlet onto the pipe connection socket.

##### Installing flexible tubing on the pipe connection socket

Turn or latch the flexible tubing onto the thread of the pipe connection socket. It is not necessary to use a hose clip to fix the tubing onto the pipe connection socket.

**Please note!**

- In case of critical installation conditions, we recommend securing the flexible tubing with an additional hose clip at the pipe connection socket.
- Plastic sheathed hot air hoses with wire inlay **must** be fixed onto the pipe connection socket with a hose clip.
- Tightening torque for hose clip = 3 Nm.

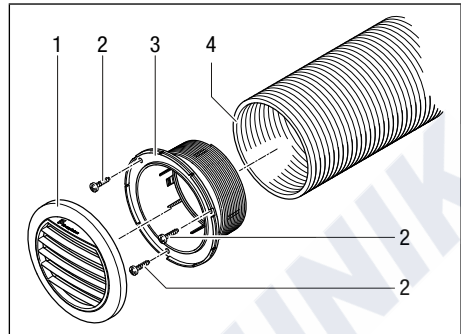

- 1 Air outlet
- 2 Self-tapping screw 3.9 x 13, EN ISO 7049
- 3 Pipe connection socket
- 4 Flexible tubing

#### Installing the air blocking element



**Caution!**

**Risk of overheating!**

Blocking the hot air can cause overheating of the heater; the heater is switched off by the protection against overheating.

- The air blocking element may only be used in multi-duct air systems.

The air blocking element is clipped into the pipe connection socket, discharge side. This reduces the cross-section of the pipe connection socket and reduces the quantity of air flow.

The air blocking element consists of two rings; the inner ring can be broken out.

1 ring = low degree of air blocking / 2 rings = high degree of air blocking

The air blocking element is available in sizes  $\varnothing$  75 mm and  $\varnothing$  90 mm (Order No. see product information).

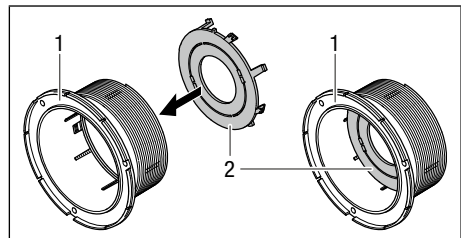

- 1 Connection sockets, discharge side
- 2 Air blocking element



### 3 Installation

#### Exhaust system

(For exhaust system diagram see page 20)

##### Installing the exhaust system

The universal installation kit includes a flexible exhaust pipe, inner  $\varnothing$  24 mm, 1300 mm long. The flexible exhaust pipe can be shortened to 20 cm or lengthened to max. 2 m, depending on the installation conditions.

In addition, an exhaust silencer can be inserted in the exhaust pipe system. In this case, fix the exhaust silencer to the vehicle in a suitable position. Lay the flexible exhaust pipe from the heater to the exhaust silencer and fasten with a pipe clip (tightening torque  $7^{+0.5}$  Nm). Connect an exhaust end pipe with an end sleeve to the exhaust silencer and fix with a pipe clip (tightening torque  $7^{+0.5}$  Nm).



##### Caution! Safety instructions!

The whole exhaust system gets very hot while the heater is running and immediately afterwards. This is why the exhaust system must be laid according to these installation instructions

- The exhaust outlet must end in the open air.
- The exhaust pipe must not protrude beyond the lateral limits of the vehicle.
- Install the exhaust pipe sloping slightly downwards. If necessary, make a drain hole with an approx.  $\varnothing$  of 5 mm at the lowest point as a condensation outlet.
- Important functional parts of the vehicle must not be impaired (keep sufficient clearance).
- Install the exhaust pipe with sufficient clearance from heat-sensitive components. Pay particular attention to fuel pipes (made of plastic or metal), electrical cables and brake hoses, etc.!
- Exhaust pipes must be safely fixed (recommended clearance of 50 cm) to avoid damage from vibrations.
- Lay the exhaust system so that the outflowing exhaust gases are not sucked in as combustion air.
- The mouth of the exhaust pipe must not become clogged with dirt and snow.
- The mouth of the exhaust pipe must not point in the direction of travel.
- Always fix the exhaust silencer to the vehicle.



##### Danger! Risk of injuries and burns!

Every type of combustion produces high temperatures and toxic exhaust fumes. This is why the exhaust system must always be laid according to these installation instructions.

- Do not perform any work on the exhaust system while the heater is working.
- Before working on the exhaust system, switch off the heater first and wait until all the parts have completely cooled down, wear safety gloves if necessary.
- Do not inhale exhaust fumes.

##### Please note!

- Comply with the regulations and safety instructions for this chapter given on page 4 – 7.
- The exhaust end pipe should be much shorter than the flexible exhaust pipe from the heater to the exhaust silencer.
- To prevent contact erosion, the clips used to fix the exhaust pipe must be made of stainless steel. The order No. for the stainless steel fixing clips is given in the product overview.

### 3 Installation

#### Combustion air system

##### Installing the combustion air system

The universal installation kit includes a combustion air silencer, which must be fitted (tightening torque  $3^{+0.5}$  Nm). If necessary, the combustion air system can be lengthened up to max. 2 m using a connector and a flexible combustion air hose, internal  $\varnothing$  25 mm (please refer to the product overview for the order no.).

Fix the combustion air silencer to the heater using a pipe clip and use a hose clip to fix at a suitable point.

**Please note!**

- The combustion air silencer must always be installed.
- Comply with the regulations and safety instructions for this chapter given on page 4 – 7.



**Caution!**

**Safety instructions for the combustion air system!**

- The combustion air opening must be free at all times.
- Lay the combustion air intake to ensure that exhaust fumes cannot be sucked in as combustion air.
- Do not point the combustion air intake against the vehicle's airstream.
- The combustion air intake must not become clogged with dirt and snow.
- Install the combustion air system sloping slightly downwards. If necessary, make a drain hole approx.  $\varnothing$  5 mm at the lowest point as a condensation outlet.

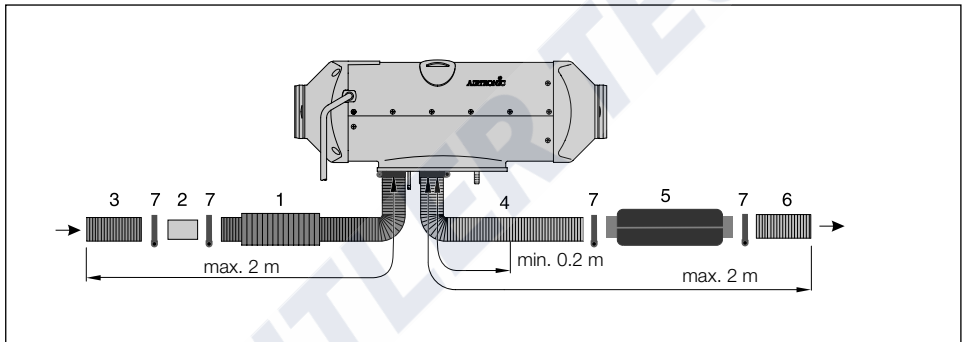

- 1 Combustion air silencer
- 2 Connection pipe, optional
- 3 Combustion air silencer, optional
- 4 Flexible exhaust pipe, di = 24 mm
- 5 Exhaust silencer, optional
- 6 Exhaust end pipe with end sleeve
- 7 Hose clip
- 8 Combustion air pipe connection
- 9 Exhaust connection

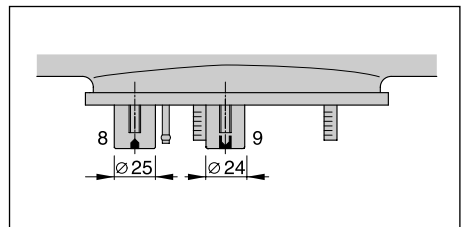



### 3 Installation

#### Fuel supply

##### Installing the dosing pump, laying the fuel pipes and installing the fuel tank

The following safety instructions must always be observed when installing the dosing pump, laying the fuel pipes and installing the fuel tank.

Deviations from the instructions stated here are not allowed.

Failure to comply can result in malfunctions.



#### **Danger!**

##### **Risk of fire, explosion, poisoning and injuries!**

Caution when handling fuel.

- Switch off the vehicle engine and the heater before refuelling and before working on the fuel supply.
- Avoid naked flames when handling fuel.
- Do not smoke.
- Do not inhale fuel vapours.
- Avoid any contact with the skin.



#### **Caution!**

##### **Safety instructions for laying the fuel pipes!**

- Only use a sharp knife to trim the fuel hoses and pipes. Interfaces must not be crushed and must be free of burrs.
- The fuel pipe from the dosing pump to the heater should be laid with a continuous rise.
- Fuel pipes must be securely fixed to avoid any damage and / or noise due to vibrations (recommended guideline value: at spacings of approx. 50 cm).
- Fuel pipes must be protected against mechanical damage.
- Lay the fuel pipes so that any distortion or shaking of the vehicle, engine movements, etc. do not have a disadvantageous effect on the service life.
- Use hose clips to secure all hose connections in the fuel supply (tightening torque 1<sup>+0.2</sup> Nm).
- Parts carrying fuel must be protected from disruptive heat.

- Never lay or fix the fuel pipes immediately next to the heater's exhaust system pipes or along the vehicle's exhaust system.

If the systems cross, always ensure there is sufficient heat clearance. If necessary, install heat radiation guards.

- Dripping or evaporating fuel must never be allowed to collect on hot parts or ignite on electric equipment.
- When connecting fuel pipes with a fuel hose, always install the fuel pipes with a butt joint to prevent any bubbles from forming.

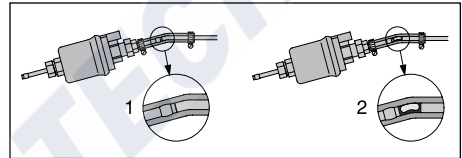

- 1 Correct connection
- 2 Pipe laid incorrectly – bubbles form



#### **Caution!**

##### **Safety instructions for fuel pipes and fuel tanks in buses and coaches!**

- In buses and coaches, fuel pipes and fuel tanks must not be routed through the passenger compartment or driver's cab.
- Fuel tanks in buses and coaches must be positioned in such a way that the exits are not in immediate danger if a fire occurs.

#### **Please note!**

Comply with the regulations and safety instructions for this chapter given on page 4 – 7.

### 3 Installation

#### Fuel supply

Fuel extraction using a T-piece from the fuel flow line, from the tank fitting to the vehicle engine

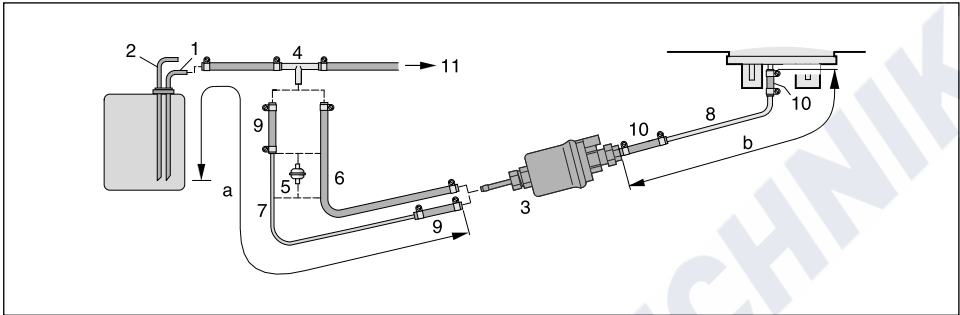

- 1 Fuel flow line from the tank connection
- 2 Fuel return line from the tank connection
- 3 Dosing pump
- 4 T-piece
- 5 Fuel filter – only needed for contaminated fuel.
- 6 Fuel hose, 5 x 3 (di = 5 mm)
- 7 Fuel pipe, 6 x 2 (di = 2 mm)
- 8\* Fuel pipe, 4 x 1.25 (di = 1.5 mm)
- 9 Fuel hose, 5 x 3 (di = 5 mm), ca. 50 mm long
- 10 Fuel hose, 3,5 x 3 (di = 3.5 mm), ca. 50 mm long
- 11 To the engine, mechanical fuel or injection pump.

\* If necessary, a fuel pipe 4 x 1 (di = 2 mm) can be used for diesel heaters instead of the fuel pipe 4 x 1.25 (di = 1.5 mm), Item (8).

The details regarding the pipe lengths remain unchanged.

The fuel pipe, 4 x 1 must be order separately, Order No. see spare parts list or product overview.

#### Permissible pipe lengths

**Intake side**  
a = max. 2 m

**Pressure side**  
b = max. 4 m for petrol  
b = max. 6 m for diesel

#### Please note!

- Insert the T-piece (4) in the fuel flow line upstream of the feed pump.
- Item (5) is not included in the scope of supply "installation kit". The order no. is given in the product overview.

#### Installation position of the T-piece

Install any T-piece in the same installation positions shown in the diagram.

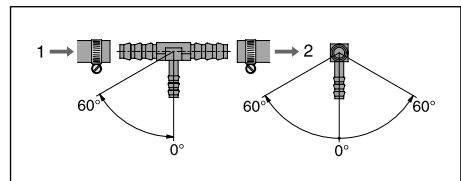

- 1 Direction of flow – from the fuel tank
- 2 Direction of flow – to the vehicle engine



### 3 Installation

#### Fuel supply

#### Fuel extraction for petrol injection engines and diesel engines

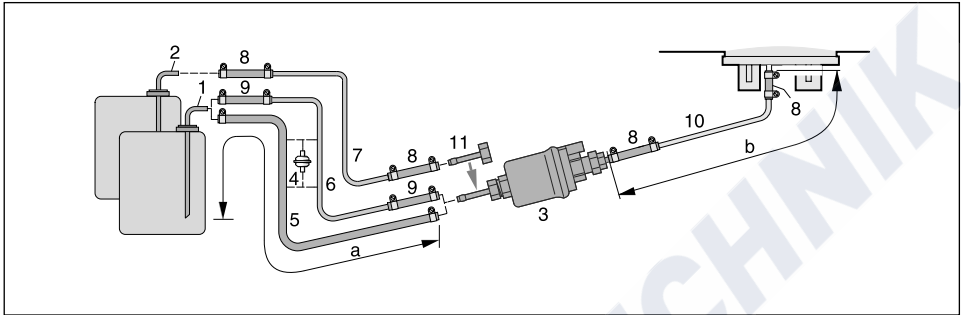

- 1 Tank connection for metal tank – di = 2 mm, da = 6 mm
- 2 Tank connection for tank fitting – di = 2 mm, da = 4 mm
- 3 Dosing pump
- 4 Fuel filter – only required for contaminated fuel.
- 5 Fuel hose, 5 x 3 (di = 5 mm)
- 6 Fuel pipe, 6 x 2 (di = 2 mm)
- 7 Fuel pipe, 4 x 1 (di = 2 mm)
- 8 Fuel hose, 3.5 x 3 (di = 3.5 mm), ca. 50 mm long
- 9 Fuel hose, 5 x 3 (di = 5 mm), ca. 50 mm long
- 10\* Fuel pipe, 4 x 1.25 (di = 1.5 mm)
- 11 Pipe connectors, da = 4 mm

\* If necessary, a fuel pipe 4 x 1 (di = 2 mm) can be used for diesel heaters instead of the fuel pipe 4 x 1.25 (di = 1.5 mm), Item (10).  
 The details regarding the pipe lengths remain unchanged.  
 The fuel pipe, 4 x 1 must be order separately, Order No. see spare parts list or product overview.

#### Permissible pipe lengths

**Intake side**  
 a = max. 2 m

**Pressure side**  
 b = max. 4 m for petrol  
 b = max. 6 m for diesel

**Please note!**

- Items (2), (7) and (11) are included in the “tank connection” kit.
- When installing tank connection maintain a minimum distance of  $50 \pm 2$  mm from the end of the riser pipe and the bottom of the tank.



**Caution!**

**Safety instructions for the fuel supply!**

- The fuel must not be discharged by means of gravity or overpressure in the fuel container.
- It is not permitted to extract fuel downstream of the vehicle's own fuel pump.
- If the pressure in the fuel pipe is more than 0.2 bar up to max. 4.0 bar, use a pressure reducer (order no. 22 1000 20 08 00) or a separate tank connection.
- If the pressure in the fuel pipe is over 4.0 bar or if there is a non-return valve in the return pipe (in the tank), a separate tank connection must be used.
- If using a T-piece in a plastic pipe, always insert support sleeves in the plastic pipe.  
 Connect the T-piece and the plastic pipe with the relevant fuel hoses and secure with hose clips.

### 3 Installation

#### Fuel supply

##### Mounting position of the dosing pump

Always install the dosing pump with the delivery side rising upwards.  
Any mounting position over 15° is allowed, although a mounting position between 15° and 35° is preferable.

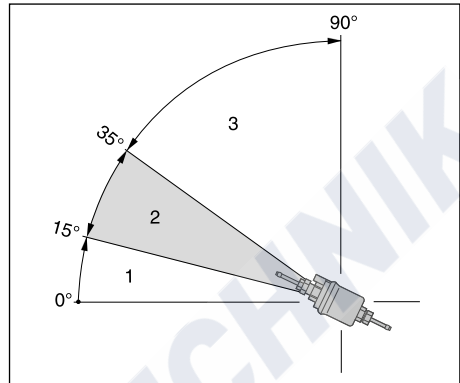

- 1 Mounting position between 0° – 15° is not allowed.
- 2 Preferred mounting position within the range 15° – 35°.
- 3 Mounting position within the range 35° – 90° is allowed.

##### Permissible suction and delivery head of the dosing pump

Delivery head from vehicle tank to dosing pump:  
a = max. 3000 mm

Suction head in pressure-less vehicle tank:  
b = max. 500 mm for petrol  
b = max. 1000 mm for diesel

Suction head in a vehicle tank in which negative pressure occurs during extraction (valve with 0.03 bar in the tank cap):  
b = max. 150 mm for petrol  
b = max. 400 mm for diesel

Delivery head from the dosing pump to the heater:  
c = Max. 2000 mm

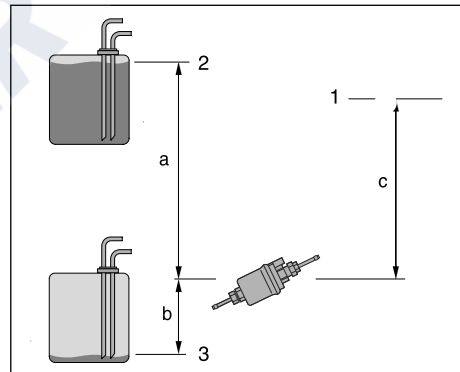

- 1 Connection at the heater
- 2 Max. fuel level
- 3 Min. fuel level

**Please note!**

Check the fuel tank vent line.



#### Caution! Safety instructions for installing the dosing pump!

- Always install the dosing pump with the delivery side rising upwards – minimum slope 15°.
- Protect the dosing pump and filter from impermissible heating, do not install near to silencers and exhaust pipes.





### 3 Installation

#### Fuel supply

##### Fuel quality for petrol heaters

The heater runs problem-free on standard commercial quality fuel in accordance with DIN EN 51600 / DIN EN 228, which you use to run your vehicle engine.

##### Fuel quality for diesel heaters

- The heater runs problem-free on standard commercial quality fuel in accordance with DIN EN 590, which you use to run your vehicle engine.
- Fuel for special cases  
In special cases the heater can also be run on heating oil (above 0 °C) or kerosene / paraffin oil.
- Fuel for low temperatures  
Refineries and petrol stations automatically adjust fuel to normal winter temperatures (winter diesel). Therefore, difficulties can only occur if there are extreme drops in temperature, the same as applies to the vehicle engine. Please also refer to the vehicle manual.
- If the heater is run from a separate tank, please comply with the following rules:  
At temperatures above 0 °C, any kind of diesel fuel to DIN EN 590 can be used.
- If no special diesel fuel is available for low temperatures, then paraffin oil / kerosene or petrol should be mixed with the fuel according to the following table:

Temperature	Winter diesel	Admixture
0 °C to -25 °C	100 %	—
-25 °C to -40 °C	50 %*	50 % paraffin oil / kerosene or petrol

\* or 100 % special cold diesel fuel (Arctic diesel)

#### Please note!

- It is not permitted to add used oil!
- After refuelling with winter or cold diesel or the listed blends, the fuel pipes and the dosing pump must be filled with the new fuel by letting the heater run for 15 minutes!

#### Operation with biodiesel (FAME)

The heater is approved for operation with biodiesel (FAME) to DIN EN 14 214 (the flowability reduces at temperatures below 0 °C).

## 4 Operation and function

### Operating instructions

The heater is operated by a control element. Detailed operating instructions are enclosed with the control unit.

#### Please note!

The workshop / garage installing the heater will issue you with the operating instructions.

### Important instructions for operation

#### Safety checks before the start

After a lengthy period of non-use (summer months) check that all parts fit securely (tighten screws where necessary).

Carry out a visual check of the fuel system for leaks.

#### Heating at high altitudes

When using the heater at high altitudes, please note:

- Heating at altitudes up to 1500 m:
  - Unlimited heating possible.
- Heating at altitudes over 1500 m:
  - Heating is possible for short periods at this altitude (e.g. driving over a mountain pass or taking a break in a journey).
  - in the event of a lengthy stay, e.g. winter camping, it is necessary to adjust the fuel supply to the altitude, please contact a JE partner for further information.

#### Please note!

Installation of an altitude kit (Order No. 22 1000 33 22 00) enables operation of diesel heaters at altitudes above 1500 m, even for a lengthy stay.

### Initial commissioning

The following points are to be checked by the company installing the heater during initial commissioning.

- After installing the heater, the whole fuel supply system must be carefully vented: please refer to and follow the vehicle manufacturer's instructions.
- During the heater trial run, all fuel connections must be checked for leaks and secure, tight fit.
- If faults occur while the heater is running, use a diagnostics device to determine and correct the cause of the fault.

#### Please note!

During the initial start-up of the heater, odours can be produced for a short time. This is fully normal during the first few minutes of operation and does not indicate a malfunction in the heater.



## 4 Operation and function

### Description of functions

#### Switching on / starting the heater

When the heater is switched on, the control lamp in the control unit lights up.

The fan starts up in the fan stage „LOW“. The glow plug starts with a 3 second delay. After approx. 50 seconds the fuel supply starts and the fuel / air mixture in the combustion chamber ignites.

The fan switches from fan stage „LOW“ to fan stage „MEDIUM“. The glow plug is switched off after 130 seconds, when a stable flame has formed.

The fan switches from fan stage „MEDIUM“ to fan stage „HIGH“.

In order to quickly reach the heater's operating temperature, the heater is run at a higher heating output of 5.5 kW („POWER“ control stage). If the heater's operating temperature has been reached, the heating output is reduced to 4.8 kW („HIGH“ control stage). The length of time for which the heater is run with an increased heating output depends on the ambient temperature.

#### Control in the heating mode

During the heating mode, the room temperature or the temperature of the sucked in heating air is constantly measured.

If the temperature is higher than the temperature selected on the control element, the heater starts to regulate its output. There are 4 control stages so that the outflow of heat produced by the heater can be adjusted finely to the heating requirements. Fan speed and fuel quantity correspond to the particular control stage.

If the set temperature is still exceeded in the smallest control stage, the heater goes to the „OFF“ stage with the fan running on for approx. 4 minutes to cool off.

The blower then continues to run at minimum speed in „MEDIUM“ control stage (circulation mode) until the restart or until it is switched off (fresh air mode with external temperature sensor).

#### Temperature selection with the control element

The control can be used to preselect an interior temperature.

The resulting temperature can be within the range of +10 °C to +30 °C and depends on the selected heater, on the size of the space to be heated and on the prevailing outdoor temperature.

The setting to be selected at the control is an empirical value.

#### Ventilating mode

The EasyStart R+ and EasyStart T control units and the Mini Controller can be used to activate the „Ventilate“ function. The „Heat / Ventilate“ switch is also required for the module timer and the control unit, whereby for fan operation, the „Heat / Ventilate“ switch must be actuated first and then the heater must be switched on. The blower runs at maximum speed in fan mode.

#### Switching off

When the heater is switched off, the control lamp goes off and the fuel supply is switched off.

The fan runs on for approx. 4 minutes to cool down.

While the fan is running on, the glow plug is switched on for approx. 30 seconds to clean.

Special case:

If no fuel has been supplied or if the heater is in the „OFF“ stage until it is switched off, the heater is stopped without any after running.

## 4 Operation and function

### Control and safety devices

- If the heater does not ignite within 90 seconds after the fuel pump is started, the start is repeated. If the heater still does not ignite after another 90 seconds of pumping fuel, a safety lock-out occurs, i. e. the fuel supply is off and the fan continues to run for approx. 4 minutes. After an impermissible number of failed start attempts, the controller is locked.\*
- If the flame goes off by itself during operation, the heater is first restarted. If the heater still does not ignite within 90 seconds after the fuel pump has been restarted, or ignites and but goes off again within 15 minutes, a safety lock-out occurs, i. e. the fuel supply is off and the fan continues to run for approx. 4 minutes. The safety lock-out can be cancelled by briefly switching off and on again. Do not repeat the switching off / on routine more than twice.
- In the case of overheating, the combined sensor (flame sensor / overheating sensor) responds, the fuel delivery is interrupted and a safety lock-out occurs. Once the cause of the overheating has been eliminated, the heater can be restarted by switching it off and on again. After an impermissible number of failed start attempts, the controller is locked.\*
- If the lower or upper voltage limit is reached, a safety lock-out occurs after 20 seconds.
- The heater will not start if the glow plug or fan motor is defective or if the electric lead to the dosing pump is interrupted.
- If the combined sensor (flame sensor / overheating sensor) is defective or the electric lead interrupted, the heater starts up and the safety lock-out does not occur until during the start phase.
- The speed of the fan's motor is continuously monitored. If the fan motor does not start up or if the speed deviates by more than 10 %, a safety lock-out occurs after 30 secs.

- When the heater is switched off, the glow plug is switched on for 40 seconds (after glowing) while the fan continues to run in order to clean off any combustion residues.
- \* The control box can be unlocked with testing equipment / a control unit. For the procedure and description for testing equipment and control units, see "Installation Instructions Plus – EasyStart/Altitude Kit / Special Functions and Diagnosis".

For operation and fault list, please refer to the enclosed operating instructions or the troubleshooting and repair instructions for the heater.

#### Please note!

Do not repeat the switching off / on routine more than twice.

#### Forced shut-down during ADR

In vehicles for the transport of dangerous goods (e. g. tankers), the heater must be switched off before the truck drives into a danger area (refinery, petrol station, etc.).

Failure to comply results in the heater automatically switching off if:

- The vehicle engine is switched off.
- An additional unit is started up (e. g. auxiliary drive for unloading pump, etc.).

The fan then continues to run briefly, for max. 40 seconds.

#### Emergency shutdown – EMERGENCY OFF

If an emergency shutdown – EMERGENCY OFF – is necessary during operation, proceed as follows:

- Switch the heater off at the control or
- remove the fuse or
- disconnect the heater from the battery.



## 5 Electrical system

### Heater wiring

The electronic control box is integrated in the heater, which considerably simplifies the wiring required during installation.



#### Caution!

#### Safety instructions!

The heater is to be connected up electrically according to the EMC Directive.

Improper tampering with the heater can affect the EMC.

For this reason, comply with the following instructions:

- Ensure that the insulation of electrical cables is not damaged.  
Avoid:  
Chafing, kinking, jamming or exposure to heat.
- Seal any connection chambers of waterproof connectors not in use with filler plugs to ensure they are dirt-proof and waterproof.
- Electrical connectors and earth connections must be free of corrosion and securely connected.
- Lubricate connectors and ground connections outside the heater interior with contact protection grease.

#### Please note!

Comply with the following when wiring the heater and the control element:

- With the appropriate electrical wiring, the heater (diesel heater, 24 volt) fulfils the ADR regulations; please refer to the circuit diagrams at the end of this document.
- Electrical leads, switch and control gear must be positioned in the vehicle so that they can function perfectly under normal operating conditions without impairment (e. g. due to heat exposure, moisture, etc.)
- The following cable cross-sections are to be used between the battery and heater. With this, the max. allowable voltage loss of 1.5 V with 12 V and 1 V with 24 V nominal voltage is not exceeded, including during the start phase (glow plug on).  
Cable cross-sections for a cable length (plus cable + minus cable) of:  
– up to 5 m = cable cross-section 4 mm<sup>2</sup>  
– from 5 m up to 8 m = cable cross-section 6 mm<sup>2</sup>
- If the plus cable is to be connected to the fuse box (e. g. terminal 30), the vehicle's cable from the battery to the fuse box must also be included in the calculation for the total cable length and re-dimensioned if necessary.
- Insulate unused cable ends.

### Parts list for circuit diagram, heater and cable harness – 12 volt/24 volt/ADR

-A10	Control box
-B3	Overheating and flame sensor
-M1	Burner motor
-R1	Glow plug
-XB3/1	Bush housing, glow plug plug-in connection
-XB3/2	Bush housing, burner motor plug-in connection
-XB3/3	Bush housing, overheating sensor plug-in connection
-XB3/4	Bush housing, flame sensor plug-in connection
-XS1	Connector housing, heater signals
-A30	Fuse holder, 2 pin
-F1	Fuse, heater
-F2	Fuse, control unit
-K2	Battery main switch (operation, e.g. controlled via ignition lock)
-S2	Battery isolating switch (emergency off function for ADR etc.)
-XB1	Bush housing, heater signals
-XB8	Bush housing, metering pump
-Y1	Fuel metering pump
a	Interface, heater / cable harness
b	Activation, vehicle fan relay (optional)
c	to the control unit
f, x	Switch cable S+, insulate cable and tie back
g	Interface, temperature – actual value, temperature setpoint
i	ADR feedback to the control unit
i1	Switch off the anti-theft alarm system
n	Generator input D+
o	Input, power take-off NA+

- Insulate unused cable ends.
- Connectors and bush housings are shown from the cable entry side.

#### Cable colours

RD	red	GR	grey	BK	black
BU	blue	YE	yellow	GN	green
WH	white	VT	violet	BN	brown
OR	orange				

## 5 Electrical system

### Heater circuit diagram

- X:15 ○ Ign (+)
- X:58 ○ Light (+)
- X:30 ○ Bat (+)
- X:31 ○ Bat (-)

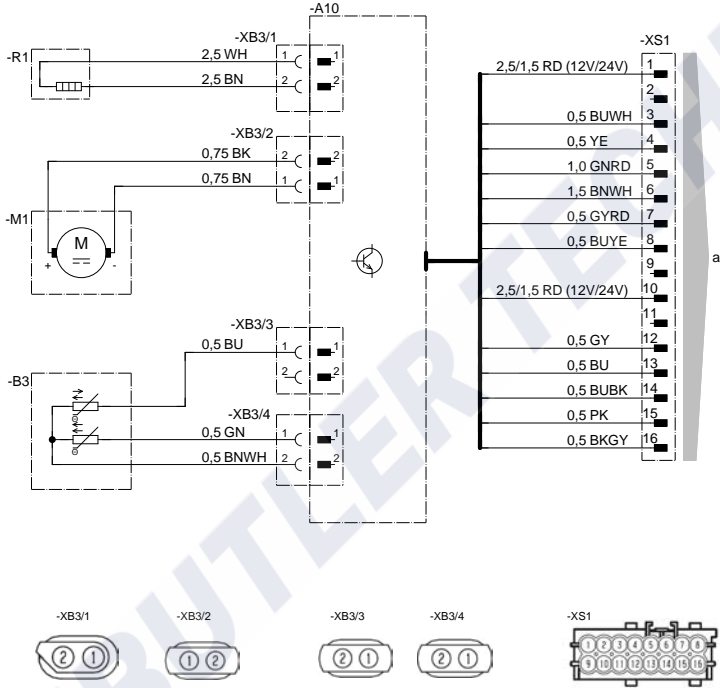

25.2361.00.9801



## 5 Electrical system

### Circuit diagram, cable harness

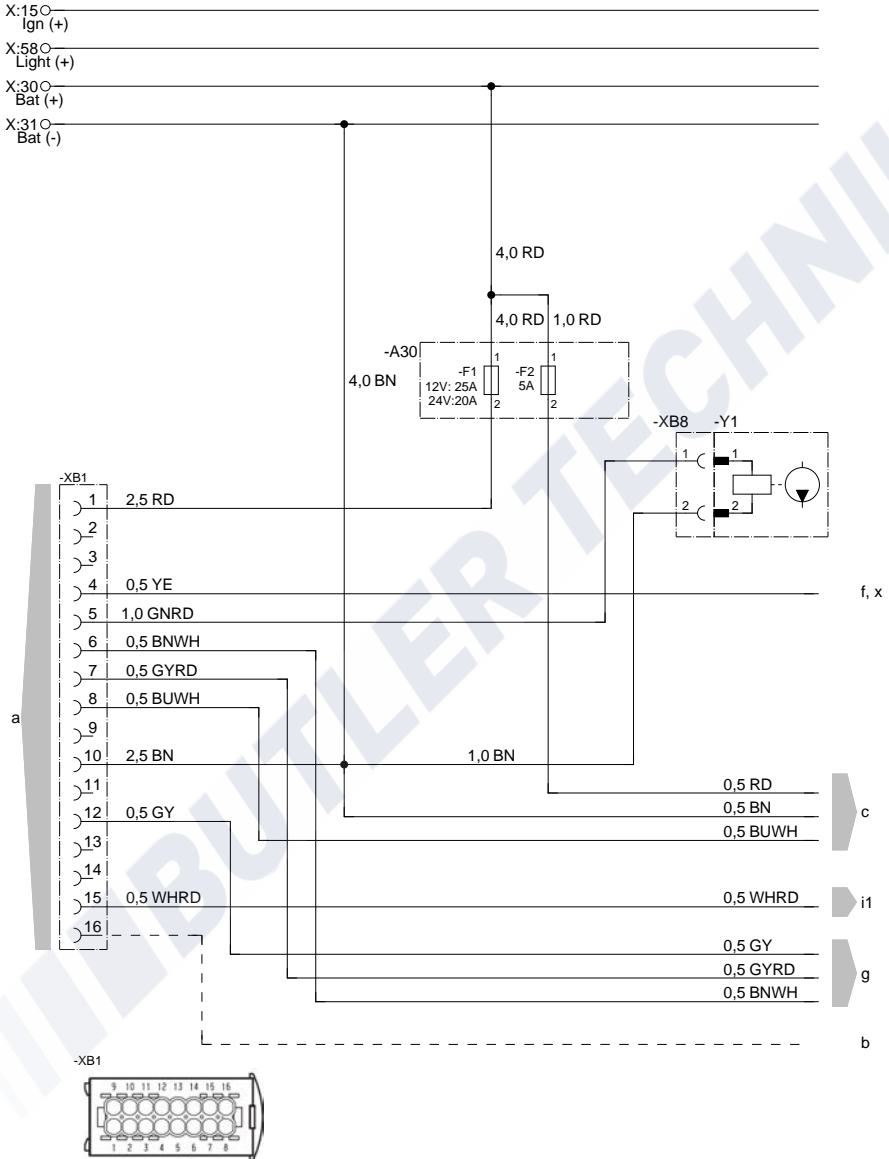

25.2361.00.9802

## 5 Electrical system

### Circuit diagram, cable harness ADR

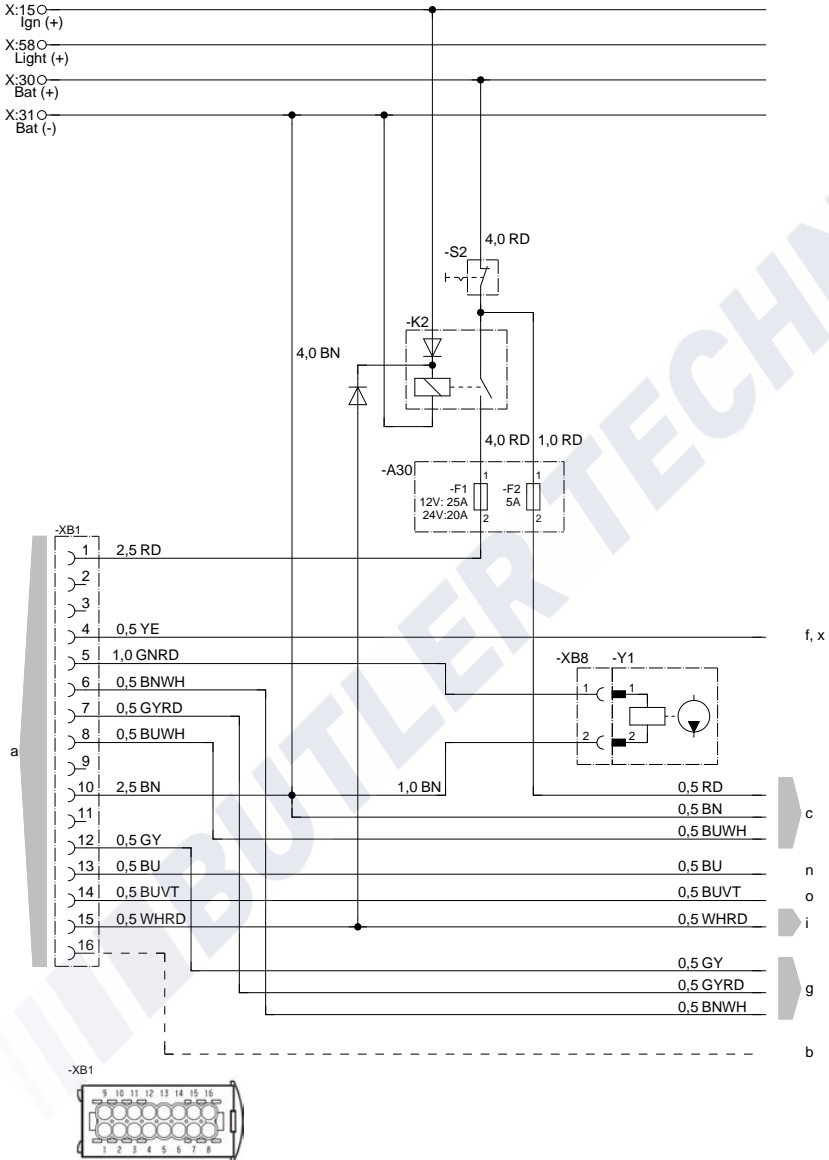

25.2361.00.9601





## 5 Electrical system

### EasyStart Timer circuit diagram

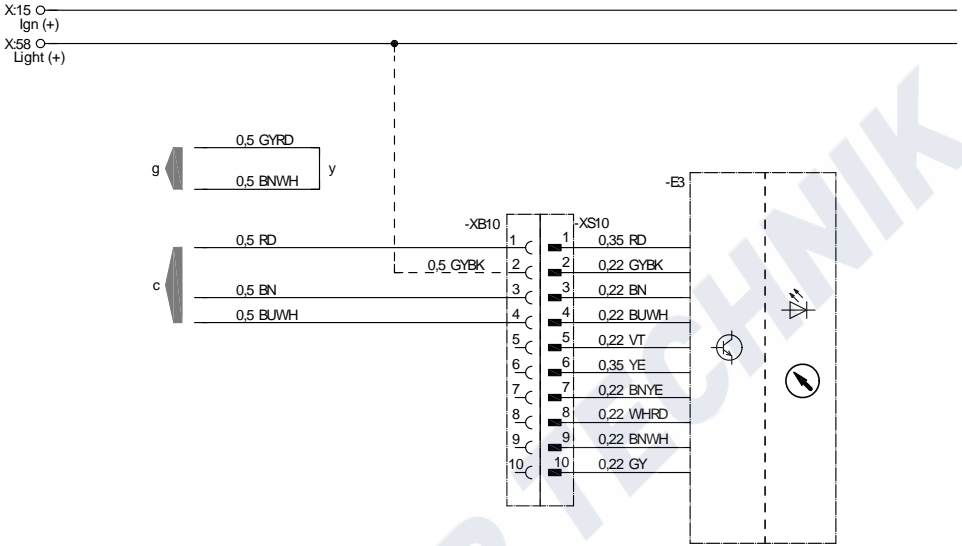

22.1000.34.9702

-E3 EasyStart Timer  
 c to the cable harness  
 g to the cable harness  
 y Connect cables and insulate

Connectors and bush housings are shown from the cable inlet side.



**Note**

Further circuit diagrams for the EasyStart Web are printed in the Installation Instructions Plus, these are available to view and download from the Service Portal.

## 5 Electrical system

### EasyStart Timer-ADR circuit diagram

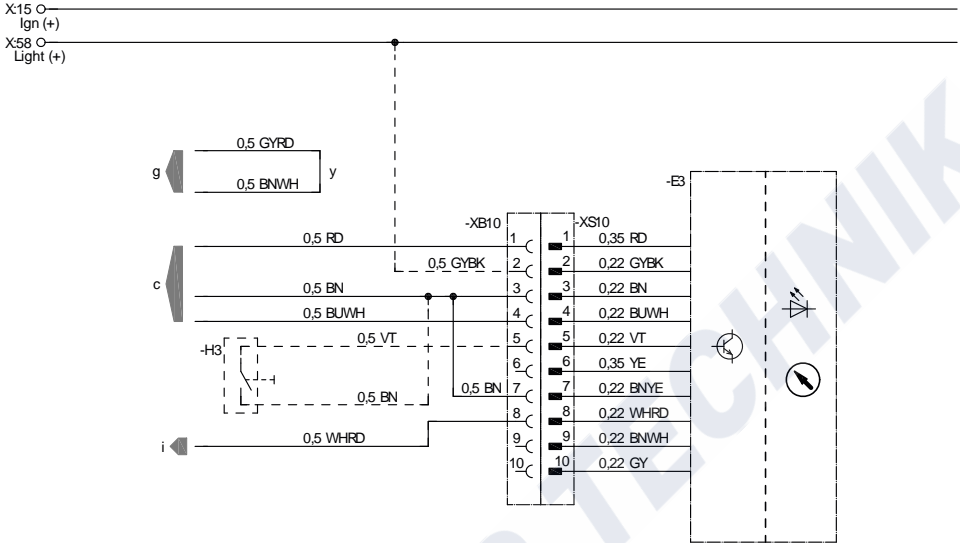

22.1000.34.9717

- E3 EasyStart Timer
- H3 Button
- c to the cable harness
- g to the cable harness
- i ADR feedback from the heater
- y Connect cables and insulate

Connectors and bush housings are shown from the cable inlet side.

**Note**

Further circuit diagrams for the EasyStart Timer are printed in the Installation Instructions Plus, these are available to view and download from the Service Portal.



## 5 Electrical system

### EasyStart Remote<sup>+</sup> circuit diagram

X:15 ○  
Ign (+)  
X:58 ○  
Light (+)

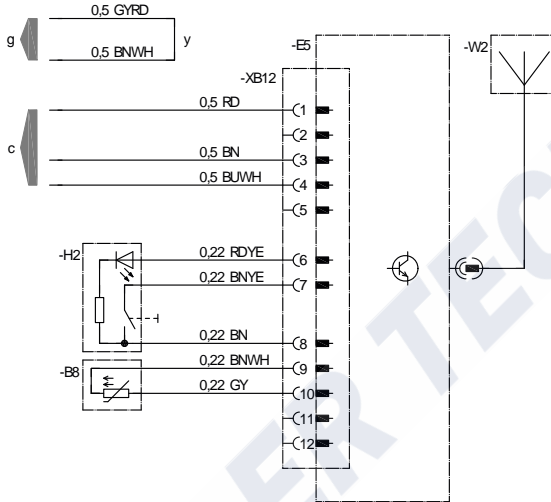

22 1000 34 9729

-B8 Room temperature sensor  
 -E5 Stationary unit, EasyStart Remote<sup>+</sup>  
 -H2 Button  
 -W2 Antenna  
 c to the cable harness  
 g to the cable harness  
 y Connect cables and insulate

Connectors and bush housings are shown from the cable inlet side.

**i Note**

Further circuit diagrams for the EasyStart Remote<sup>+</sup> are printed in the Installation Instructions Plus, these are available to view and download from the Service Portal.

## 5 Electrical system

### EasyStart Select circuit diagram

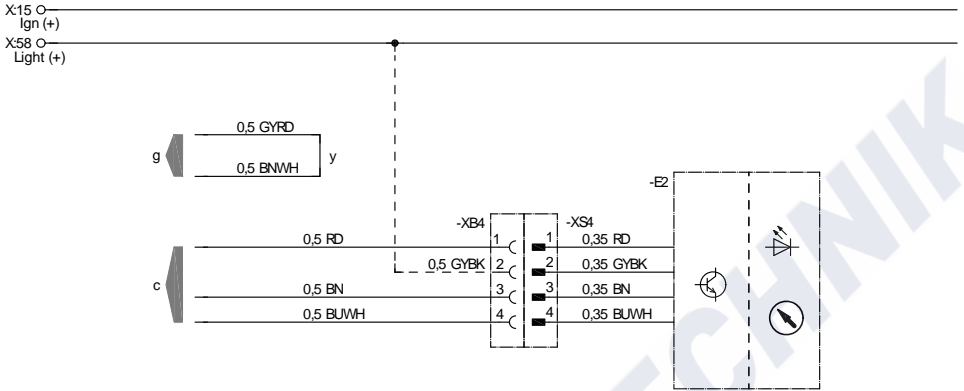

22.1000.34.9734

- E2 EasyStart Select
- c to the cable harness
- g to the cable harness
- y Connect cables and insulate

Connectors and bush housings are shown from the cable inlet side.



#### Note

Further circuit diagrams for the EasyStart Select are printed in the Installation Instructions Plus, these are available to view and download from the Service Portal.



## 5 Electrical system

### EasyStart Web circuit diagram

X:15○  
Ign (+)  
X:58○  
Light (+)

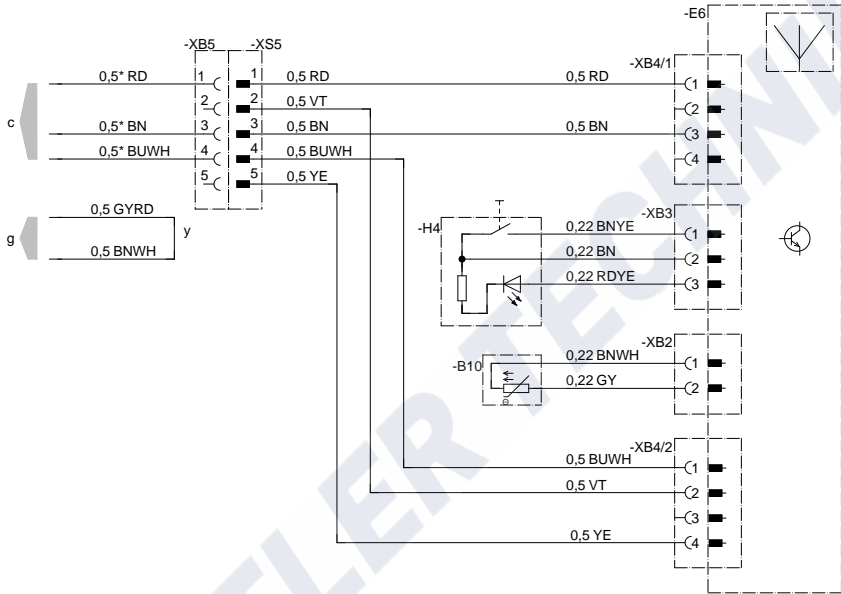

22.1000.34.9719

-B10 Room temperature sensor  
-E6 EasyStart Web  
-H4 Button  
c to the cable harness  
g to the cable harness  
y Connect cables and insulate

Connectors and bush housings are shown from the cable inlet side.

#### **i** Note

Further circuit diagrams for the EasyStart Web are printed in the Installation Instructions Plus, these are available to view and download from the Service Portal.

## 6 Troubleshooting / maintenance / service

---

### If any faults occur, please check the following items

- If the heater does not start after being switched on:
  - Switch the heater off and on again.
- If the heater still won't start, then check whether:
  - There is fuel in the tank?
  - The fuses are ok?
  - The electrical cables, connections, terminals, are ok?
  - The hot air, combustion air or exhaust systems are blocked?

### Troubleshooting

If, after checking these items, the heater is still faulty or another malfunction occurs in your heater, please contact:

- If factory-installed, your contract workshop / garage.
- If subsequently installed, the workshop / garage which installed the heater.

**Please note!**

Please note that guarantee claims can expire if the heater is modified by a third party or if non-original parts are installed.

### Maintenance instructions

- Switch the heater on once a month for about 10 minutes, even outside the heating period.
- Before the heating period starts, a trial run should be carried out for the heater. If thick, persistent smoke develops, unusual burning noises or a clear fuel smell occurs or if electric / electronic parts overheat, the heater must be switched off and put out of service by removing the fuse. In this case, the heater should not be started up again until it has been checked by qualified staff who have been trained on Eberspächer heaters.
- Check the openings of the hot air, combustion air and exhaust systems after lengthy stoppages, clean if necessary!

### Service

#### Technical Support

If you have any technical questions or problems with the heater, the control unit or the operating software, please contact the following service address:  
[support-UK@eberspaecher.com](mailto:support-UK@eberspaecher.com)



## 7 Environment

### Certification

The high quality of Eberspächer products is the key to our success.

To guarantee this quality, we have organised all work processes in the company for the purposes of quality management (QM).

Nevertheless, we still pursue a large number of activities for continuous improvement of product quality in order to keep pace with our customers' constantly growing requirements.

All the steps necessary for quality assurance are stipulated in international standards.

This quality is to be considered in a comprehensive and total sense.

It affects products, procedures and customer/supplier relations.

Officially approved experts assess the system and the corresponding certification company awards a certificate.

Eberspächer Climate Control Systems GmbH & Co. KG has already qualified for the following standards:

#### **Quality management in accordance with ISO TS 9001:2015 and IATF 16949:2016**

#### **Environmental management system in accordance with ISO 14001:2015**

### Disposal

#### **Disposal of materials**

Old devices, defective components and packaging materials can all be separated and sorted into pure-grade fractions, if necessary, so that all parts can be disposed of in an environment-friendly way or the materials recycled.

Electric motors, controllers and sensors (e. g. temperature sensors) are deemed to be "electronic scrap".

#### **Dismantling the heater**

The heater is dismantled according to the repair stages in the current troubleshooting / repair instructions.

#### **Packaging**

The heater's packaging can be kept in case it has to be sent back.

### EU Declaration of Conformity

We herewith declare that the version of the heater placed on the market by us conforms to the applicable provisions of the following EU Directive.

EU Directive 2014/30/EU



The full Declaration of Conformity can be viewed and downloaded from the download centre under [www.eberspaecher.com](http://www.eberspaecher.com).

## 8 List

---

### List of abbreviations

#### **ADR**

European agreement on the international transport of dangerous goods by road.

#### **ECE regulation**

Internationally agreed, uniform technical specifications for vehicles, parts and equipment of motor vehicles.

#### **EC type approval**

Approval awarded by the German Federal Office for Motor Traffic for the production of a heater for installation in motorised vehicles.

#### **EMC Directives**

Electromagnetic compatibility.

#### **FAME**

Biodiesel according to DIN V 14 214.

#### **JE-partner**

Eberspächer partner.



/// BUTLER TECHNIK

/// BUTLER TECHNIK

/// BUTLER TECHNIK

[www.butlertechnik.com](http://www.butlertechnik.com)

[www.eberspaecher.com](http://www.eberspaecher.com)

Eberspächer Climate Control Systems  
GmbH & Co. KG  
Eberspächerstr. 24  
D - 73730 Esslingen  
[info@eberspaecher.com](mailto:info@eberspaecher.com)



[www.butlertechnik.com](http://www.butlertechnik.com)